

Attachment 9

CALIFORNIA ENVIRONMENTAL QUALITY ACT
ENVIRONMENTAL INITIAL STUDY CHECKLIST FORM
Public Review Period May 12, 2023 – June 2, 2023
Recirculation

- 1. PROJECT TITLE:** Peterbilt Service Center (P22-0017)
Billboard Sign (P23-0019)

Entitlements: Development Plan (PD22-02) for a Peterbilt Sales and Service Center
Conditional Use Permit (CUP22-16) for a highway-oriented sign
Rezone (RZN22-03) to expand the Highway-Oriented Sign overlay district
Conditional Use Permit (CUP23-03) for a billboard sign
- 2. LEAD AGENCY:** City of Paso Robles
1000 Spring Street
Paso Robles, CA 93446

Contact: Katie Banister
Phone: (805) 237-3970
Email: kbanister@prcity.com
- 3. PROJECT LOCATION:** 2805 Theatre Drive
Paso Robles, CA 93446
APN: 009-851-022
- 4. PROJECT PROPONENTS:**

Proponent: Archer Paso Robles, LLC
Contact: Pamela Jardini
Phone: 805-801-0453
Email: planningsolutions@charter.net

Proponent: Outfront Media, LLC
Contact: Armen Devejian
Phone: 559-389-8166
Email: devejian@adeinc.biz
- 5. GENERAL PLAN DESIGNATION:** Regional Commercial (RC)
- 6. ZONING:** Commercial Highway with Planned Development Overlay (C2 PD)
- 7. PROJECT DESCRIPTION:** Development plan for the construction of a

Attachment 9

25,000 square-foot semi-truck service, parts retailer, and sales dealership. Expansion of the Highway-Oriented Sign overlay district, and new highway-oriented sign. New billboard sign to replace an existing billboard sign.

8. ENVIRONMENTAL SETTING:

The 6.6-acre property is nearly level. The site is undeveloped except for existing frontage improvements and an existing billboard sign. Vegetation is a mix of non-native herbaceous plants and several native oak trees. The Salinas River is located approximately 4,000 feet to the east of the property (east of Highway 101). The property is at the southern boundary of the city. Properties to the north are developed with commercial uses. Properties to the south are developed with residential uses. The property to the west is currently undeveloped, but is entitled for a mini-storage development. A low-density residential neighborhood is located further to the west. Highway 101 is located to the east of the property.

9. OTHER AGENCIES WHOSE APPROVAL IS REQUIRED (AND PERMITS NEEDED):

None

10. Have California Native American tribes traditionally and culturally affiliated with the project area requested consultation pursuant to Public Resources Code section 21080.3.1? If so, is there a plan for consultation that includes, for example, the determination of significance of impacts to tribal cultural resources, procedures regarding confidentiality, etc.?

No

Attachment 9

ENVIRONMENTAL FACTORS POTENTIALLY AFFECTED:

The environmental factors checked below would be potentially affected by this project, involving at least one impact that is a "Potentially Significant Impact" as indicated by the checklist on the following pages.

- | | | |
|--|--|---|
| <input checked="" type="checkbox"/> Aesthetics | <input type="checkbox"/> Agriculture / Forestry Resources | <input checked="" type="checkbox"/> Air Quality |
| <input checked="" type="checkbox"/> Biological Resources | <input checked="" type="checkbox"/> Cultural Resources | <input type="checkbox"/> Energy |
| <input checked="" type="checkbox"/> Geology/Soils | <input checked="" type="checkbox"/> Greenhouse Gas Emissions | <input checked="" type="checkbox"/> Hazards & Hazardous Materials |
| <input type="checkbox"/> Hydrology/Water Quality | <input type="checkbox"/> Land Use / Planning | <input type="checkbox"/> Mineral Resources |
| <input checked="" type="checkbox"/> Noise | <input type="checkbox"/> Population / Housing | <input type="checkbox"/> Public Services |
| <input type="checkbox"/> Recreation | <input type="checkbox"/> Transportation | <input type="checkbox"/> Tribal Cultural Resources |
| <input type="checkbox"/> Utilities / Service Systems | <input type="checkbox"/> Wildfire | <input type="checkbox"/> Mandatory Findings of Significance |

DETERMINATION: (To be completed by the Lead Agency)

On the basis of this initial evaluation:

- I find that the proposed project COULD NOT have a significant effect on the environment, and a NEGATIVE DECLARATION will be prepared.
- I find that although the proposed project could have a significant effect on the environment, there will not be a significant effect in this case because revisions in the project have been made by or agreed to by the project proponent. A MITIGATED NEGATIVE DECLARATION will be prepared.
- I find that the proposed project MAY have a significant effect on the environment, and an ENVIRONMENTAL IMPACT REPORT is required.
- I find that the proposed project MAY have a "potentially significant impact" or "potentially significant unless mitigated" impact on the environment, but at least one effect 1) has been adequately analyzed in an earlier document pursuant to applicable legal standards, and 2) has been addressed by mitigation measures based on the earlier analysis as described on attached sheets. An ENVIRONMENTAL IMPACT REPORT is required, but it must analyze only the effects that remain to be addressed.
- I find that although the proposed project could have a significant effect on the environment, because all potentially significant effects (a) have been analyzed adequately in an earlier EIR or NEGATIVE DECLARATION pursuant to applicable standards, and (b) have been avoided or mitigated pursuant to that earlier EIR or NEGATIVE DECLARATION, including revisions or mitigation measures that are imposed upon the proposed project, nothing further is required.



Signature:

May 12, 2023

Date

Attachment 9

EVALUATION OF ENVIRONMENTAL IMPACTS:

1. A brief explanation is required for all answers except “No Impact” answers that are adequately supported by the information sources a lead agency cites in the parentheses following each question. A “No Impact” answer is adequately supported if the referenced information sources show that the impact simply does not apply to projects like the one involved (e.g., the project falls outside a fault rupture zone). A “No Impact” answer should be explained where it is based on project-specific factors as well as general standards (e.g., the project will not expose sensitive receptors to pollutants, based on a project-specific screening analysis).
2. All answers must take account of the whole action involved. Answers should address off-site as well as on-site, cumulative as well as project-level, indirect as well as direct, and construction as well as operational impacts.
3. “Once the lead agency has determined that a particular physical impact may occur, then the checklist answers must indicate whether the impact is potentially significant, less than significant with mitigation, or less than significant. “Potentially Significant Impact” is appropriate if there is substantial evidence that an effect may be significant. If there are one or more “Potentially Significant Impact” entries when the determination is made, an EIR is required.
4. “Negative Declaration: Less Than Significant With Mitigation Incorporated” applies where the incorporation of mitigation measures has reduced an effect from “Potentially Significant Impact” to a “Less Than Significant Impact.” The lead agency must describe the mitigation measures, and briefly explain how they reduce the effect to a less than significant level (mitigation measures from “Earlier Analyses,” as described in (5) below, may be cross-referenced).
5. Earlier analyses may be used where, pursuant to the tiering, program EIR, or other CEQA process, an effect has been adequately analyzed in an earlier EIR or negative declaration. Section 15063(c)(3)(D). In this case, a brief discussion should identify the following:
 - a. Earlier Analysis Used. Identify and state where they are available for review.
 - b. Impacts Adequately Addressed. Identify which effects from the above checklist were within the scope of and adequately analyzed in an earlier document pursuant to applicable legal standards, and state whether such effects were addressed by mitigation measures based on the earlier analysis.
 - c. Mitigation Measures. For effects that are "Less than Significant with Mitigation Measures Incorporated," describe the mitigation measures which were incorporated or refined from the earlier document and the extent to which they address site-specific conditions for the project.

Lead agencies are encouraged to incorporate into the checklist references to information sources for potential impacts (e.g., general plans, zoning ordinances). Reference to a previously prepared or outside document should, where appropriate, include a reference to the page or pages where the statement is substantiated.

Supporting Information Sources: A source list should be attached, and other sources used or individuals contacted should be cited in the discussion.

The explanation of each issue should identify:

- a. the significance criteria or threshold, if any, used to evaluate each question; and
- b. the mitigation measure identified, if any, to reduce the impact to less than significance

Potentially Significant Impact	Less Than Significant with Mitigation Incorporated	Less Than Significant Impact	Impact
--------------------------------------	--	------------------------------------	--------

I. AESTHETICS: Would the project:

- a. Have a substantial adverse effect on a scenic vista?

Discussion: The site is located at the southern boundary of the city adjacent to the southern Highway 101 Gateway to the City. The General Plan Conservation Element identifies the full length of Highway 101 as a visual corridor, where “development shall be designed to make a positive visual impression” and “Billboards shall be limited in number”. Action Item 2 of General Plan Land Use Element Policy LU-2B includes “Enhancing views along highways, roads, streets, and rail corridors with landscaping, building setbacks, enhanced architecture and signage/monuments.” The project would include the demolition of an existing billboard and development of the site with a commercial building, a highway-oriented sign, and a replacement billboard sign. The design of the building has been reviewed by the City Development Review Committee and is similar to the architecture of other vehicle dealerships in the vicinity.

The existing billboard is located about 5 feet from the pavement of Theatre Drive (and if not removed, would have been over the sidewalk that will be constructed with this project). The sign is 22 feet tall with 400 square feet of sign area facing south and 600 square feet of sig area facing north. The replacement billboard would be located 35 feet further west from Theatre Drive and Highway 101. It would have reduced sign area with 300 square feet facing each north and south, but its height would be increased to 30 feet. Although it is proposed to be taller, the replacement billboard would have less sign area and be further away from Highway 101. Considering all these factors together, the aesthetic impact of the new billboard to the Highway 101 visual corridor will be comparable to the aesthetic impact of the existing billboard. In addition, the billboard is subject to a conditional use permit and the Planning Commission and/or City Council may add additional conditions to further ensure the billboard is compatible with the neighboring area and City plans and policies. With the following mitigation measure implemented, the billboard will have a less than significant impact:

Mitigation Measure AES-1 would require shielding of any lights on the billboard, so the light source is not visible from adjacent roadways or properties zoned for residential use.

The project includes a request to erect a freeway-oriented sign for Peterbilt (the proposed onsite business). This sign would add an additional sign visible and readable from the highway. The sign is similar in scale and design to signs for other car dealerships on Theatre Drive, namely Kia (with a 28-foot-tall sign) and Chevrolet (with an approximately 30-foot-tall sign). The proposed freeway-oriented sign requires rezoning to expand the Highway-Oriented Sign overlay district to the subject property and approval of a conditional use permit to ensure compatibility of the sign with the neighborhood. The highway-oriented sign will have a less than significant aesthetic impact when the following mitigation measures are implemented.

Mitigation Measure AES-2 would require the proposed freeway-oriented sign for Peterbilt to be limited to a maximum of 30 feet in height.

Mitigation Measure AES-3 would require any future freeway-oriented sign for a business developed on the southern portion of the lot be collocated with the freeway-oriented sign for the Peterbilt project.

Mitigation Measure AES-4 would require landscaping and street trees along the entire property frontage.

- b. Substantially damage scenic resources, including, but not limited to, trees, rock outcroppings, and historic buildings within a state scenic highway?

Discussion: The property includes several mature native oak trees, which will be retained with the project. Three 4-inch diameter oak saplings are proposed for removal. These trees fall below the size protected by the

	Potentially Significant Impact	Less Than Significant with Mitigation Incorporated	Less Than Significant Impact	Significant Impact
Oak Tree Preservation Ordinance. The impact is less than significant.				
c. Substantially degrade the existing visual character or quality of public views of the site and its surroundings? (Public views are those that are experienced from publicly accessible vantage point). If the project is in an urbanized area, would the project conflict with applicable zoning and other regulations governing scenic quality?	<input type="checkbox"/>	<input type="checkbox"/>	<input checked="" type="checkbox"/>	<input type="checkbox"/>
Discussion: This site is in an urbanized area visible from Highway 101, Theatre Drive and Nutwood Circle. The proposed design of the development is in keeping with other commercial developments in the vicinity including Kia and Chevrolet dealerships, vehicle repair shops, and an RV sales use.				
d. Create a new source of substantial light or glare which would adversely affect day or nighttime views in the area?	<input type="checkbox"/>	<input checked="" type="checkbox"/>	<input type="checkbox"/>	<input type="checkbox"/>
Discussion: Electronic reader copy is prohibited on billboard signs. Standard conditions of approval and Mitigation Measure AES-1 require any exterior lights to be shielded to prevent offsite glare, so the impact will be less than significant.				

II. AGRICULTURE AND FOREST RESOURCES:

In determining whether impacts to agricultural resources are significant environmental effects, lead agencies may refer to the California Agricultural Land Evaluation and Site Assessment Model (1997) prepared by the California Dept. of Conservation as an optional model to use in assessing impacts on agriculture and farmland. Would the project:

a. Convert Prime Farmland, Unique Farmland, or Farmland of Statewide Importance (Farmland), as shown on the maps prepared pursuant to the Farmland Mapping and Monitoring Program of the California Resources Agency, to non-agricultural use?	<input type="checkbox"/>	<input type="checkbox"/>	<input checked="" type="checkbox"/>	<input type="checkbox"/>
Discussion: The site is in an urbanized area and will not have an impact on agricultural resources. The Natural Resources Conservation Service (NRCS) has mapped one soil map unit on the site, the Lockwood channery loam, 0-2 percent slopes ¹⁰ , which is prime farmland if irrigated with a land capability class of 3s (severe limitations) when not irrigated, however, the Farmland Mapping and Monitoring Program of the California Resources Agency and the Open Space Element of the Paso Robles General Plan (Figure OS-1, Important Farmland) identify the site as Urban / Built-Up Land ^{1, 12} . The site is surrounded by urban uses and is not under cultivation, nor has it been for at least 20 years.				
b. Conflict with existing zoning for agricultural use, or a Williamson Act contract?	<input type="checkbox"/>	<input type="checkbox"/>	<input type="checkbox"/>	<input checked="" type="checkbox"/>
Discussion: The site is not under Williamson Act contract, nor is it currently used for agricultural purposes.				
c. Conflict with existing zoning for, or cause rezoning of, forest, land (as defined in Public	<input type="checkbox"/>	<input type="checkbox"/>	<input type="checkbox"/>	<input checked="" type="checkbox"/>

	Potentially Significant Impact	Less Than Significant with Mitigation Incorporated	Less Than Significant Impact	Significant Impact
--	--------------------------------------	--	------------------------------------	-----------------------

Resources Code section 12220(g)), timberland (as defined by Public Resources Code section 4526), or timberland zoned Timberland Production (as defined by Government Code section 5114(g))?

Discussion: There are no forest land or timberland resources within the City of Paso Robles.

- | | | | | |
|--|--------------------------|--------------------------|--------------------------|-------------------------------------|
| d. Result in the loss of forest land or conversion of forest land to non-forest use? | <input type="checkbox"/> | <input type="checkbox"/> | <input type="checkbox"/> | <input checked="" type="checkbox"/> |
|--|--------------------------|--------------------------|--------------------------|-------------------------------------|

Discussion: The City of Paso Robles does not contain forest land resources. Three 4-inch oak saplings are proposed for removal, however the trees are scattered on the site and do not constitute a forest.

- | | | | | |
|--|--------------------------|--------------------------|--------------------------|-------------------------------------|
| e. Involve other changes in the existing environment which, due to their location or nature, could result in conversion of Farmland, to non-agricultural use or conversion of forest land to non-forest use? | <input type="checkbox"/> | <input type="checkbox"/> | <input type="checkbox"/> | <input checked="" type="checkbox"/> |
|--|--------------------------|--------------------------|--------------------------|-------------------------------------|

Discussion: The site is located within the city limits of Paso Robles and surrounded by urbanized uses. The project will have no impact on conversion of farmland.



III. AIR QUALITY: Where available, the significance criteria established by the applicable air quality management or air pollution control district may be relied upon to make the following determinations. Would the project:

- | | | | | |
|---|--------------------------|-------------------------------------|-------------------------------------|--------------------------|
| a. Conflict with or obstruct implementation of the applicable air quality plan? | <input type="checkbox"/> | <input type="checkbox"/> | <input checked="" type="checkbox"/> | <input type="checkbox"/> |
| b. Result in a cumulatively considerable net increase of any criteria pollutant for which the project region is non-attainment under an applicable federal or state ambient air quality standard? | <input type="checkbox"/> | <input type="checkbox"/> | <input checked="" type="checkbox"/> | <input type="checkbox"/> |
| c. Expose sensitive receptors to substantial pollutant concentrations? | <input type="checkbox"/> | <input checked="" type="checkbox"/> | <input type="checkbox"/> | <input type="checkbox"/> |

Discussion (a-c): The San Luis Obispo County area is a non-attainment area for the state standards for ozone and suspended particulate matter⁹. The potential for future project development to create adverse air quality impacts falls generally into two categories: short-term (construction-related) and long-term (operational) impacts. The SLO County Air Pollution Control District (APCD) provides guidance for calculating air quality impacts.

Projects that do not exceed operational thresholds are unlikely to exceed construction thresholds as well.

The project is the construction of approximately 25,000 square feet of light industrial space. A CalEEMod analysis was completed for the project (Attachment 3), which found, during construction, the project is expected to generate an average of 7.86 pounds per day of ROG and NO_x, 0.23 pounds per day of diesel particulate matter and 0.23 pounds per day of fugitive dust. Projects have a significant impact if they generate 137 pounds or more of ROG + NO_x daily during construction. The project falls below the construction phase air quality significance thresholds.

**Potentially
Significant
Impact**

**Less Than
Significant
with
Mitigation
Incorporated**

**Less Than
Significant
Impact**

Impact

Construction Emissions

Pollutant	Project Average Max	Project Summer Max	Significance Threshold	Significance Determination
ROG + NO _x	7.86 lb/day	80.2 lb/day	137 lb/day	Less than significant
Diesel PM	0.23 lb/day	1.81 lb/day	7 lb/day	Less than significant
Fugitive Dust PM ₁₀	0.23 lb/day	2.76 lb/day (0.5T/quarter)	2.5 T/quarter	Less than significant

The site is approximately 300 feet from the closest residences in the Rancho Paso Mobile Home Park, which are sensitive receptors. Air Quality impacts to sensitive receptors are less than significant with San Luis Obispo Air Pollution Control District standard mitigation measures (AQ-1 through AQ-26) implemented.

Operations Emissions

Pollutant	Project Average	Project Summer Max	Significance Threshold	Significance Determination
ROG + NO _x	1.21 lb/day	2.14 lb/day	25 lb/day	Less than significant
Diesel PM	0.23	1.81 lb/day		Less than significant
Fugitive Dust PM ₁₀	0.01 lb/day	0.01 lb/day		Less than significant

Operational emissions will have a less than significant impact.

- d. Result in other emissions (such as those leading to odors) adversely affecting a substantial number of people?

Discussion: According to the SLOAPCD, land uses commonly considered to be potential sources of noxious odorous emissions include painting/coating operations. Mitigation Measure HAZ-1 would prohibit vehicle fuel sales and painting of vehicles, which would reduce the impact to less than significant.

IV. BIOLOGICAL RESOURCES: Would the project:

- a. Have a substantial adverse effect, either directly or through habitat modifications, on any species identified as a candidate, sensitive, or special status species in local or regional plans, policies, or regulations, or by the California Department of Fish and Game or U.S. Fish and Wildlife Service?

Discussion: The site is disturbed. A manufactured home sales business previously occupied approximately 1.7 acres at the corner with Nutwood Circle. A fenced stormwater basin is located at the northwest corner of the lot. Several soil stockpiles are scattered on the site. Urban uses ring the site except the lots immediately west and northwest of the site, which are undeveloped. Highway 101 is to the east of the property.

A biological resources assessment report was prepared for the project (Attachment 4). No sensitive vegetative communities or designated critical habitats are located on the site. No special status botanical species were

Potentially Significant Impact	Less Than Significant with Mitigation Incorporated	Less Than Significant Impact	Significant Impact
--------------------------------------	--	------------------------------------	-----------------------

observed during a site survey, which occurred in March, which is part of the typical blooming period for potentially occurring species in the region. Three special-status wildlife species have the potential to occur on the site, however none were observed during an onsite survey. Mitigation measures are provided to reduce potential impacts to the northern legless lizard, American badger, and San Joaquin kit fox. Similarly, mitigation measures are provided to protect nesting birds that may be impacted if construction begins between February 1 and August 31.

- b. Have a substantial adverse effect on any riparian habitat or other sensitive natural community identified in local or regional plans, policies, regulations or by the California Department of Fish and Game or US Fish and Wildlife Service?
- | | | | | |
|--|--------------------------|-------------------------------------|--------------------------|--------------------------|
| | <input type="checkbox"/> | <input checked="" type="checkbox"/> | <input type="checkbox"/> | <input type="checkbox"/> |
|--|--------------------------|-------------------------------------|--------------------------|--------------------------|

Discussion: There are no riparian or sensitive natural communities on the site. Several oak saplings are proposed for removal with the project. Oak tree mitigation is required for the removal of any oak tree over 6 inches in diameter.

- c. Have a substantial adverse effect on federally protected wetlands as defined by Section 404 of the Clean Water Act (including, but not limited to, marsh, vernal pool, coastal, etc.) through direct removal, filling, hydrological interruption, or other means?
- | | | | | |
|--|--------------------------|--------------------------|--------------------------|-------------------------------------|
| | <input type="checkbox"/> | <input type="checkbox"/> | <input type="checkbox"/> | <input checked="" type="checkbox"/> |
|--|--------------------------|--------------------------|--------------------------|-------------------------------------|

Discussion: There are no wetlands on the site.

- d. Interfere substantially with the movement of any native resident or migratory fish or wildlife species or with established native resident or migratory wildlife corridors, or impede the use of native wildlife nursery sites?
- | | | | | |
|--|--------------------------|--------------------------|--------------------------|-------------------------------------|
| | <input type="checkbox"/> | <input type="checkbox"/> | <input type="checkbox"/> | <input checked="" type="checkbox"/> |
|--|--------------------------|--------------------------|--------------------------|-------------------------------------|

Discussion: There are no creeks or drainages leading to creeks on the site. The site is in an urbanized area.

- e. Conflict with any local policies or ordinances protecting biological resources, such as a tree preservation policy or ordinance?
- | | | | | |
|--|--------------------------|--------------------------|-------------------------------------|--------------------------|
| | <input type="checkbox"/> | <input type="checkbox"/> | <input checked="" type="checkbox"/> | <input type="checkbox"/> |
|--|--------------------------|--------------------------|-------------------------------------|--------------------------|

Discussion: The project protects the 3 mature oak trees on the property. Three oak saplings are proposed for removal, one of which is larger than 6 inches in diameter and will be subject to oak tree mitigation.

- f. Conflict with the provisions of an adopted Habitat Conservation Plan, Natural Community Conservation Plan, or other approved local, regional, or state habitat conservation plan?
- | | | | | |
|--|--------------------------|--------------------------|--------------------------|-------------------------------------|
| | <input type="checkbox"/> | <input type="checkbox"/> | <input type="checkbox"/> | <input checked="" type="checkbox"/> |
|--|--------------------------|--------------------------|--------------------------|-------------------------------------|

Potentially Significant Impact	Less Than Significant with Mitigation Incorporated	Less Than Significant Impact	Impact
---	---	---	---------------

Discussion: There are no conservation plans adopted for the City of Paso Robles, therefore no impact is expected.



V. CULTURAL RESOURCES: Would the project:

- | | | | | |
|---|--------------------------|--------------------------|--------------------------|-------------------------------------|
| <p>a. Cause a substantial adverse change in the significance of a historical resource as defined in §15064.5?</p> | <input type="checkbox"/> | <input type="checkbox"/> | <input type="checkbox"/> | <input checked="" type="checkbox"/> |
|---|--------------------------|--------------------------|--------------------------|-------------------------------------|

Discussion (a): The site is undeveloped. No historical resources were identified during an onsite survey of the site conducted in support of the preparation of a cultural resources inventory survey for the site (Attachment 5).

- | | | | | |
|--|--------------------------|-------------------------------------|--------------------------|--------------------------|
| <p>b. Cause a substantial adverse change in the significance of an archaeological resource pursuant to §15064.5?</p> | <input type="checkbox"/> | <input checked="" type="checkbox"/> | <input type="checkbox"/> | <input type="checkbox"/> |
|--|--------------------------|-------------------------------------|--------------------------|--------------------------|

Discussion (b): No archeological resources have been identified on the site. Mitigation measure CUL-1 would require work to stop should any cultural resources or human remains be identified on the site during construction.

- | | | | | |
|---|--------------------------|-------------------------------------|--------------------------|--------------------------|
| <p>c. Disturb any human remains, including those interred outside of formal cemeteries?</p> | <input type="checkbox"/> | <input checked="" type="checkbox"/> | <input type="checkbox"/> | <input type="checkbox"/> |
|---|--------------------------|-------------------------------------|--------------------------|--------------------------|

Discussion (c): No archeological resources have been identified on the site. Mitigation measure CUL-1 would require work to stop should any cultural resources or human remains be identified on the site during construction.



VI. ENERGY: Would the project:

- | | | | | |
|--|--------------------------|--------------------------|-------------------------------------|--------------------------|
| <p>a. Result in potentially significant environmental impact due to wasteful, inefficient, or unnecessary consumption of energy resources, during project construction or operation?</p> | <input type="checkbox"/> | <input type="checkbox"/> | <input checked="" type="checkbox"/> | <input type="checkbox"/> |
|--|--------------------------|--------------------------|-------------------------------------|--------------------------|

Discussion (a): The project would use typical construction techniques and vehicle repair equipment. No wasteful consumption of energy is proposed.

- | | | | | |
|--|--------------------------|--------------------------|--------------------------|-------------------------------------|
| <p>b. Conflict with or obstruct a state or local plan for renewable energy or energy efficiency?</p> | <input type="checkbox"/> | <input type="checkbox"/> | <input type="checkbox"/> | <input checked="" type="checkbox"/> |
|--|--------------------------|--------------------------|--------------------------|-------------------------------------|

Discussion (b): The proposed project will not conflict with any adopted plan for renewable energy or energy efficiency.



VII. GEOLOGY AND SOILS: Would the project:

- a. Directly or indirectly cause potential

	Potentially Significant Impact	Less Than Significant with Mitigation Incorporated	Less Than Significant Impact	Significant Impact
substantial adverse effects, including the risk of loss, injury, or death involving:				
i. Rupture of a known earthquake fault, as delineated on the most recent Alquist-Priolo Earthquake Fault Zoning Map issued by the State Geologist for the area or based on other substantial evidence of a known fault? Refer to Division of Mines and Geology Special Publication 42.	<input type="checkbox"/>	<input type="checkbox"/>	<input type="checkbox"/>	<input checked="" type="checkbox"/>
<p>Discussion: The potential for and mitigation of impacts that may result from fault rupture in the project area are identified and addressed in the EIR for the 2003 update of the General Plan¹. There are two known nearby fault zones, one on each side of the Salinas River Valley. The Rinconada Fault system runs on the west side of the valley, and grazes the City on its western boundary, but has been inactive for approximately 11,000 years. The San Andreas Fault is on the east side of the valley and is situated about 23 miles northeast of Paso Robles. The City of Paso Robles recognizes these geologic influences in the application of the Uniform Building Code to all new development within the City including the proposed project. There are no Alquist-Priolo Earthquake Fault Zones within City limits.</p>				
ii. Strong seismic ground shaking?	<input type="checkbox"/>	<input type="checkbox"/>	<input type="checkbox"/>	<input checked="" type="checkbox"/>
<p>Discussion: The 2003 General Plan EIR identified impacts resulting from ground shaking as less than significant and provided mitigation measures that will be incorporated into the design of all construction projects including adequate structural design over active or potentially active faults. Therefore, there are no expected impacts from seismic ground shaking.</p>				
iii. Seismic-related ground failure, including liquefaction?	<input type="checkbox"/>	<input checked="" type="checkbox"/>	<input type="checkbox"/>	<input type="checkbox"/>
<p>Discussion: The General Plan Safety Element includes Figure S-3, a map of citywide Liquefaction Risk, which classifies the site as high risk. Mitigation Measure GEO-1 would require a soils report for the project, which will address specific onsite liquefaction risks and reduce the impact to less than significant.</p>				
iv. Landslides?	<input type="checkbox"/>	<input type="checkbox"/>	<input type="checkbox"/>	<input checked="" type="checkbox"/>
<p>Discussion: The General Plan Safety Element includes Figure S-4, a map of citywide Landslide Risk. The site has low potential for landslides. Landslides are generally associated with steep slopes and specific geologic formations not found in proximity to the Salinas River. The site is flat. No impact is anticipated.</p>				
b. Result in substantial soil erosion or the loss of topsoil?	<input type="checkbox"/>	<input checked="" type="checkbox"/>	<input type="checkbox"/>	<input type="checkbox"/>
<p>Discussion: The site is flat with loamy soil. The Paso Robles Area Soil Survey Map prepared by the Natural Resources Conservation Service (NRCS) indicates the site's soil is Lockwood shaly loam, which is highly erodible¹⁰. Mitigation Measure GEO-2 would require a Stormwater Pollution Prevention Plan (SWPPP) designed by a Qualified SWPPP Developer to prevent significant erosion from the site.</p>				
c. Be located on a geologic unit or soil that is unstable, or that would become unstable as a result of the project, and potentially result in	<input type="checkbox"/>	<input checked="" type="checkbox"/>	<input type="checkbox"/>	<input type="checkbox"/>

	Potentially Significant Impact	Less Than Significant with Mitigation Incorporated	Less Than Significant Impact	Impact
--	--------------------------------------	--	------------------------------------	--------

on- or off-site landslide, lateral spreading, subsidence, liquefaction or collapse?

Discussion: See response to items a.iii. and a.iv. above. Mitigation Measures GEO-1 would reduce the impact to less than significant.

- | | | | | |
|--|--------------------------|--------------------------|-------------------------------------|--------------------------|
| d. Be located on expansive soil, as defined in Table 18-1-B of the Uniform Building Code (1994), creating substantial risks to life or property? | <input type="checkbox"/> | <input type="checkbox"/> | <input checked="" type="checkbox"/> | <input type="checkbox"/> |
|--|--------------------------|--------------------------|-------------------------------------|--------------------------|

Discussion: The Paso Robles Area San Luis Obispo County Soil Survey indicates the Lockwood shaly loam has moderate shrink swell potential. Mitigation Measure GEO-1 would reduce the potential impact to less than significant.

- | | | | | |
|--|--------------------------|--------------------------|--------------------------|-------------------------------------|
| e. Have soils incapable of adequately supporting the use of septic tanks or alternative waste water disposal systems where sewers are not available for the disposal of waste water? | <input type="checkbox"/> | <input type="checkbox"/> | <input type="checkbox"/> | <input checked="" type="checkbox"/> |
|--|--------------------------|--------------------------|--------------------------|-------------------------------------|

Discussion: The project is required to connect to the City sewer. A 10-inch sewer main is located in Theatre Drive, and is available to the project.

- | | | | | |
|---|--------------------------|--------------------------|--------------------------|-------------------------------------|
| f. Directly or indirectly destroy a unique paleontological resource or site or unique geologic feature? | <input type="checkbox"/> | <input type="checkbox"/> | <input type="checkbox"/> | <input checked="" type="checkbox"/> |
|---|--------------------------|--------------------------|--------------------------|-------------------------------------|

Discussion: No known paleontological resources or unique geological features are known to exist on the site. No impacts are expected.

VIII. GREENHOUSE GAS EMISSIONS: Would the project:

- | | | | | |
|--|--------------------------|--------------------------|-------------------------------------|--------------------------|
| a. Generate greenhouse gas emissions, either directly or indirectly, that may have a significant impact on the environment? | <input type="checkbox"/> | <input type="checkbox"/> | <input checked="" type="checkbox"/> | <input type="checkbox"/> |
| b. Conflict with any applicable plan, policy, or regulation of an agency adopted for the purpose of reducing the emissions of greenhouse gasses? | <input type="checkbox"/> | <input type="checkbox"/> | <input checked="" type="checkbox"/> | <input type="checkbox"/> |

Discussion: San Luis Obispo Air Pollution Control District Screening Criteria for Project Air Quality Analysis⁹, updated in 2017 indicates Light Industrial uses less than 92,000 square feet in size is not expected to exceed the Greenhouse Gas Numerical Threshold of 1150 MT/year of CO₂, which was used to meet statewide emission standards required by 2020. Senate Bill 32, adopted in 2016, requires a further 40% reduction in Greenhouse Gas Emissions by 2030. A 40% reduction in the threshold for CO₂ emissions would imply a 55,200 square-foot or smaller Light Industry use would not exceed the lower threshold. The project is 25,000 square feet of light industrial use. Results from the CalEEMod analysis for the project indicate the project will generate 5,929 lb CO₂/day during construction and 3,782 lb CO₂/day during operation.

The 2030 Greenhouse Gas Efficient Threshold for Paso Robles is 1.9 MTCO_{2e}/Service Population/year (2030 Service Population is estimated at 53,717). Results from the CalEEMod analysis indicate the construction

Potentially Significant Impact	Less Than Significant with Mitigation Incorporated	Less Than Significant Impact	Impact
--------------------------------------	--	------------------------------------	--------

phase of the project will generate 315 MTCO_{2e}. Amortized over 25 years, the construction emissions are 12.6 MTCO_{2e}/year. Operational emissions (including the amortized construction emissions) are 638.6 MTCO_{2e}/year, or 16.8 MTCO_{2e}/SP/year (38 employees estimated by CCTC Transportation Analysis).

Qualitatively, the project is consistent with the following goals and policies of the San Luis Obispo APCD Climate Transportation and Land Use Control Measures:

- L-1 Planning Compact Communities. The project is located within city limits.
 - L-3 Balancing Jobs and Housing. The project will create jobs and help to balance the jobs/housing imbalance in northern San Luis Obispo County.
 - L-4 Circulation Management and T-2B Regional Public Transit Improvements. The project is located on a regional transit route, RTA Route 9, which has connections to Paso Robles City transit services.
 - T-3 Bicycling and Bikeway Enhancements. The project will construct a bike lane along the Theatre Drive frontage.
- Mitigation Measure GHG-1 will reduce the impact to less than significant. T

IX. HAZARDS AND HAZARDOUS MATERIALS: Would the project:

- a. Create a significant hazard to the public or the environment through the routine transport, use, or disposal of hazardous materials?

Discussion (a): The proposed project is a semi-truck service and sales center. Diesel repair includes the routine handling of relatively small amounts of hazardous materials including diesel fuel, engine oil, degreasing solvents, tires, and waste batteries. The handling of these materials is subject to regulations enforced by the San Luis Obispo County Department of Environmental Health. Mitigation Measure HAZ-1 would prevent the project from operating as a service station dispensing fuel. Mitigation Measure HAZ-2 would require the applicant to apply to the SLO County Department of Environmental Health for permits appropriate for vehicle repair services. These mitigations measures would reduce the hazard to the public to a less than significant impact.

- b. Create a significant hazard to the public or the environment through reasonably foreseeable upset and accident conditions involving the release of hazardous materials into the environment?

Discussion (b): Vehicle repair services have some potential to cause accident conditions, however Mitigation Measure HAZ-1 would prohibit fuel sales and painting vehicles, which would eliminate several significant potential accident hazards. Measure HAZ-2 would require the project to comply with SLO County Environmental Health rules, which reduces the potential impacts to a less than significant level.

- c. Emit hazardous emissions or handle hazardous or acutely hazardous materials, substances, or waste within one-quarter mile of an existing or proposed school?

Discussion (a-c): The project is not within a quarter mile of any school. The nearest school is Templeton Hills Adventist School located approximately 2 miles southwest of the project.

	Potentially Significant Impact	Less Than Significant with Mitigation Incorporated	Less Than Significant Impact	Impact
--	--------------------------------------	--	------------------------------------	--------

- d. Be located on a site which is included on a list of hazardous materials sites compiled pursuant to Government Code Section 65962.5 and, as a result, would it create a significant hazard to the public or the environment?

	<input type="checkbox"/>	<input type="checkbox"/>	<input type="checkbox"/>	<input checked="" type="checkbox"/>
--	--------------------------	--------------------------	--------------------------	-------------------------------------

Discussion (d) The proposed project is not listed on the Cortese List compiled by the California Department of Toxic Substances Control¹⁷.

- e. For a project located within an airport land use plan or, where such a plan has not been adopted, within two miles of a public airport or public use airport, would the project result in a safety hazard or excessive noise for people residing or working in the project area?

	<input type="checkbox"/>	<input type="checkbox"/>	<input type="checkbox"/>	<input checked="" type="checkbox"/>
--	--------------------------	--------------------------	--------------------------	-------------------------------------

Discussion (e): The project site is not within the Airport Land Use Plan area. No impact is anticipated.

- f. Impair implementation of or physically interfere with an adopted emergency response plan or emergency evacuation plan?

	<input type="checkbox"/>	<input type="checkbox"/>	<input type="checkbox"/>	<input checked="" type="checkbox"/>
--	--------------------------	--------------------------	--------------------------	-------------------------------------

Discussion: The City of Paso Robles maintains a Multi-Hazard Emergency Response Plan, most recently updated in 2019. The project is on private land adjacent to an arterial road. The project would not interfere with the plan or impede emergency evacuation.

- g. Expose people or structures, either directly or indirectly, to a significant risk of loss, injury or death involving wildland fires?

	<input type="checkbox"/>	<input type="checkbox"/>	<input checked="" type="checkbox"/>	<input type="checkbox"/>
--	--------------------------	--------------------------	-------------------------------------	--------------------------

Discussion: The city does not contain any very-high fire severity zones. The site is in an urbanized area and not adjacent to wildlands. The project would not create a significant impact.

X. HYDROLOGY AND WATER QUALITY: Would the project:

- a. Violate any water quality standards or waste discharge requirements or otherwise substantially degrade surface or ground water quality?

	<input type="checkbox"/>	<input type="checkbox"/>	<input checked="" type="checkbox"/>	<input type="checkbox"/>
--	--------------------------	--------------------------	-------------------------------------	--------------------------

Discussion: The is subject to stormwater management requirements both during construction and operation. The project will not impact water quality or significantly increase industrial waste discharged to the city sewer.

- b. Substantially decrease groundwater supplies or interfere substantially with groundwater recharge such that the project may impede

	<input type="checkbox"/>	<input type="checkbox"/>	<input checked="" type="checkbox"/>	<input type="checkbox"/>
--	--------------------------	--------------------------	-------------------------------------	--------------------------

	Potentially Significant Impact	Less Than Significant with Mitigation Incorporated	Less Than Significant Impact	Impact
--	--------------------------------------	--	------------------------------------	--------

sustainable groundwater management of the basin?

Discussion: The project site is within city limits and is currently zoned to allow for highway-oriented commercial uses.

The project is consistent with the 2016 Urban Water Management Plan (UWMP)⁵, which anticipates and plans for buildout of the City. Since the UWMP has accounted for land uses at the project site, the project will have adequate water supply available, and will not further deplete or significantly affect, change or increase water demands planned for use in the basin. The site is not suitable for significant groundwater recharge.

The impact of the project would be less than significant.

- | | | | | |
|---|--------------------------|--------------------------|--------------------------|-------------------------------------|
| <p>c. Substantially alter the existing drainage pattern of the site or area, including through the alteration of the course of a stream or river or through the addition of impervious surfaces, in a manner which would:</p> | <input type="checkbox"/> | <input type="checkbox"/> | <input type="checkbox"/> | <input checked="" type="checkbox"/> |
| i) result in a substantial erosion or siltation on- or off-site; | <input type="checkbox"/> | <input type="checkbox"/> | <input type="checkbox"/> | <input checked="" type="checkbox"/> |
| ii) substantially increase the rate or amount of surface runoff in a manner which would result in flooding on- or offsite; | <input type="checkbox"/> | <input type="checkbox"/> | <input type="checkbox"/> | <input checked="" type="checkbox"/> |
| iii) create or contribute runoff water which would exceed the capacity of existing or planned stormwater drainage systems or provide substantial additional sources of polluted runoff; or | <input type="checkbox"/> | <input type="checkbox"/> | <input type="checkbox"/> | <input checked="" type="checkbox"/> |
| iv) impede or redirect flood flows? | <input type="checkbox"/> | <input type="checkbox"/> | <input type="checkbox"/> | <input checked="" type="checkbox"/> |

Discussion: The site is very flat with no significant drainage channels. Grading will further flatten the lot and divert runoff from new impervious surfaces to a stormwater detention basin. Mitigation Measure GEO-2 would require a SWPPP be prepared for the project to prevent significant erosion and site runoff.

- | | | | | |
|--|--------------------------|--------------------------|-------------------------------------|--------------------------|
| <p>d. In flood hazard, tsunami, or seiche zones, risk release of pollutants due to project inundation?</p> | <input type="checkbox"/> | <input type="checkbox"/> | <input checked="" type="checkbox"/> | <input type="checkbox"/> |
|--|--------------------------|--------------------------|-------------------------------------|--------------------------|

Discussion: The project site is outside all local floodplains. The site is about 80 feet above the Salinas River. The risk of flood is less than significant.

- | | | | | |
|---|--------------------------|--------------------------|-------------------------------------|--------------------------|
| <p>e. Conflict with or obstruct implementation of a water quality control plan or sustainable groundwater management plan</p> | <input type="checkbox"/> | <input type="checkbox"/> | <input checked="" type="checkbox"/> | <input type="checkbox"/> |
|---|--------------------------|--------------------------|-------------------------------------|--------------------------|

Discussion: The 2011 Central Coast Basin Water Quality Control Plan adopted by the Central Coast Regional Water Quality Control Board¹⁵ provides water quality regulations in the region through controls including waste discharge restrictions and stormwater management. Industrial waste discharges from the project will be managed through the City's Industrial Waste program. The City's Urban Water Master Plan⁵ is designed to serve all uses anticipated at full buildout. The City is a Groundwater Sustainability Agency for a portion of the Paso Robles Sub-Basin of the Salinas Basin. The commercial uses proposed by the project are

Potentially Significant Impact	Less Than Significant with Mitigation Incorporated	Less Than Significant Impact	Impact
--------------------------------------	--	------------------------------------	--------

consistent with the Paso Robles Subbasin Groundwater Sustainability Plan¹⁸. The project does not conflict with the applicable water quality control plan not the sustainable groundwater management plan; impacts would be less than significant.

XI. LAND USE AND PLANNING: Would the project:

- | | | | | |
|--|--------------------------|--------------------------|--------------------------|-------------------------------------|
| a. Physically divide an established community? | <input type="checkbox"/> | <input type="checkbox"/> | <input type="checkbox"/> | <input checked="" type="checkbox"/> |
|--|--------------------------|--------------------------|--------------------------|-------------------------------------|

Discussion: The project is a commercial development in a commercial district. It is adjacent to Highway 101. Separate neighborhoods are located to the west and south of the site, but no established community would be physically divided

- | | | | | |
|--|--------------------------|--------------------------|-------------------------------------|--------------------------|
| b. Cause a significant environmental impact due to a conflict with any land use plan, policy, or regulation adopted for the purpose of avoiding or mitigating an environmental effect? | <input type="checkbox"/> | <input type="checkbox"/> | <input checked="" type="checkbox"/> | <input type="checkbox"/> |
|--|--------------------------|--------------------------|-------------------------------------|--------------------------|

Discussion: The project is a highway-oriented commercial business in the Highway Commercial zoning district (C-2). As mitigated, the project is not in conflict with any land use plan, policy, or regulation adopted for the purpose of avoiding or mitigating an environmental effect including the Paso Robles Gateway Plan⁸ (see discussion in Aesthetics section above), Hillside Development District standards⁴, and Purple Belt Action Plan.

XII. MINERAL RESOURCES: Would the project:

- | | | | | |
|---|--------------------------|--------------------------|--------------------------|-------------------------------------|
| a. Result in the loss of availability of a known mineral resource that would be of value to the region and the residents of the state? | <input type="checkbox"/> | <input type="checkbox"/> | <input type="checkbox"/> | <input checked="" type="checkbox"/> |
| b. Result in the loss of availability of a locally-important mineral resource recovery site delineated on a local general plan, specific plan or other land use plan? | <input type="checkbox"/> | <input type="checkbox"/> | <input type="checkbox"/> | <input checked="" type="checkbox"/> |

Discussion (a-b): No mineral resources are known to occur on the site.

XIII. NOISE: Would the project result in:

- | | | | | |
|---|--------------------------|-------------------------------------|--------------------------|--------------------------|
| a. Exposure of persons to or generation of noise levels in excess of standards established in the local general plan or noise ordinance, or applicable standards of other agencies? | <input type="checkbox"/> | <input checked="" type="checkbox"/> | <input type="checkbox"/> | <input type="checkbox"/> |
|---|--------------------------|-------------------------------------|--------------------------|--------------------------|

Discussion: An Environmental Noise Assessment was prepared for the project (Attachment 6). Without mitigation, truck circulation and service department equipment noise would exceed the noise exposure allowed by Noise Ordinance^{1,4} standards. Mitigation Measure N-1 would limit hours of operation, Measure N-2 would require service doors to be closed in service bays facing south and west when air hammers are in

<p>Potentially Significant Impact</p>	<p>Less Than Significant with Mitigation Incorporated</p>	<p>Less Than Significant Impact</p>	<p>Impact</p>
--	--	--	----------------------

use, and Measure N-3 would prohibit use of air hammers and hydraulic lifts outside the building.

Public address (PA) systems are common to vehicle repair uses; however, the project description does state whether a PA system is proposed. Mitigation Measure N-4 would require any PA system proposed in the future to be designed to meet noise limitations.

As mitigated, the project is not expected to create noise beyond what is permitted by the City Noise Element and Noise Ordinance so the impact would be less than significant.

- | | | | | |
|---|--------------------------|--------------------------|-------------------------------------|--------------------------|
| b. Generation of excessive groundborne vibration or groundborne noise levels? | <input type="checkbox"/> | <input type="checkbox"/> | <input checked="" type="checkbox"/> | <input type="checkbox"/> |
|---|--------------------------|--------------------------|-------------------------------------|--------------------------|

Discussion: Groundborne noise and vibration is expected only during construction of the project, however it will be short-lived and only during allowed construction hours (7am and 7pm, Monday-Saturday). The expected impact is less than significant.

- | | | | | |
|---|--------------------------|--------------------------|--------------------------|-------------------------------------|
| c. For a project located within the vicinity of a private airstrip or an airport land use plan or, where such a plan has not been adopted, within two miles of a public airport or public use airport, would the project expose people residing or working in the project area to excessive noise levels? | <input type="checkbox"/> | <input type="checkbox"/> | <input type="checkbox"/> | <input checked="" type="checkbox"/> |
|---|--------------------------|--------------------------|--------------------------|-------------------------------------|

Discussion: The project site is not within the Airport Land Use Plan area. No significant noise impact from the airport is expected.

XIV. POPULATION AND HOUSING: Would the project:

- | | | | | |
|---|--------------------------|--------------------------|--------------------------|-------------------------------------|
| a. Induce substantial population growth in an area, either directly (for example, by proposing new homes and businesses) or indirectly (for example, through extension of roads or other infrastructure)? | <input type="checkbox"/> | <input type="checkbox"/> | <input type="checkbox"/> | <input checked="" type="checkbox"/> |
| b. Displace substantial numbers of existing housing, necessitating the construction of replacement housing elsewhere? | <input type="checkbox"/> | <input type="checkbox"/> | <input type="checkbox"/> | <input checked="" type="checkbox"/> |

Discussion (a-b): The project is on an infill site near the southern boundary of the City. Sewer is currently available to the site, however City water service will be extended to serve the project. Water service is currently available to adjacent residential neighborhoods outside the City from the Walnut Hills Mutual Water Company and Templeton Community Services District. City services are not available outside the City and due to current availability of water in the existing developments located in the County, the extension of the water main will not induce population growth.

The project will not displace any existing housing.

XV. PUBLIC SERVICES: Would the project:

- | | | | | |
|---|--------------------------|--------------------------|-------------------------------------|--------------------------|
| a. Result in substantial adverse physical | <input type="checkbox"/> | <input type="checkbox"/> | <input checked="" type="checkbox"/> | <input type="checkbox"/> |
|---|--------------------------|--------------------------|-------------------------------------|--------------------------|

<p>Potentially Significant Impact</p>	<p>Less Than Significant with Mitigation Incorporated</p>	<p>Less Than Significant Impact</p>	<p>Impact</p>
--	--	--	----------------------

impacts associated with the provision of new or physically altered governmental facilities, need for new or physically altered governmental facilities, the construction of which could cause significant environmental impacts, in order to maintain acceptable service ratios, response times, or other performance objectives for any of the public services?

Fire protection?	<input type="checkbox"/>	<input type="checkbox"/>	<input checked="" type="checkbox"/>	<input type="checkbox"/>
Police protection?	<input type="checkbox"/>	<input type="checkbox"/>	<input checked="" type="checkbox"/>	<input type="checkbox"/>
Schools?	<input type="checkbox"/>	<input type="checkbox"/>	<input checked="" type="checkbox"/>	<input type="checkbox"/>
Parks?	<input type="checkbox"/>	<input type="checkbox"/>	<input checked="" type="checkbox"/>	<input type="checkbox"/>
Other public facilities?	<input type="checkbox"/>	<input type="checkbox"/>	<input checked="" type="checkbox"/>	<input type="checkbox"/>

Discussion: The project is not expected to significant increase demands on the fire and police departments because it is a light industrial use. No significant increase in demand on school, parks and other public facilities is expected by commercial uses. The proposed project is subject to development impact fees and school fees, which address the incremental increase in demand on public services caused by the project.



XVI. RECREATION

- a. Would the project increase the use of existing neighborhood and regional parks or other recreational facilities such that substantial physical deterioration of the facility would occur or be accelerated?
- b. Does the project include recreational facilities or require the construction or expansion of recreational facilities which might have an adverse physical effect on the environment?

Discussion (a-b): The project is a light industrial / commercial project, which will not create a significant demand on existing parks. No new parks are proposed as a part of the project.



XVII. TRANSPORTATION: Would the project:

- a. Conflict with a program, plan, ordinance or policy addressing the circulation system, including transit, roadway, bicycle and pedestrian facilities?

Discussion: The project includes the widening of Theatre Drive, which is identified in the Circulation Plan plan as an undivided arterial. Widening will accommodate two travel lanes, bikes lanes and a center turn lane consistent with City standards.

	Potentially Significant Impact	Less Than Significant with Mitigation Incorporated	Less Than Significant Impact	Impact
<p>b. Conflict or be inconsistent with CEQA Guidelines § 15064.3, subdivision (b)?</p> <p>Discussion: A transportation analysis was completed for the project (Attachment 7), which concluded the project will have a less than significant impact on vehicle miles traveled (VMT) based on the City’s 2022 Transportation Impact Analysis Guidelines thresholds, which indicate, “Office and industrial projects may have a significant impact if the work VMT per employee exceeds 85 percent of the regional average”. Based on the SLOCOG Travel Demand Model, the project is expected to have a work VMT lower than the threshold of significance.</p>	<input type="checkbox"/>	<input type="checkbox"/>	<input checked="" type="checkbox"/>	<input type="checkbox"/>
<p>c. Substantially increase hazards due to a geometric design feature (e.g., sharp curves or dangerous intersections) or incompatible uses (e.g., farm equipment)?</p> <p>Discussion: The project is located on a straight stretch of Theatre Drive. Because access to Highway 101 is restricted to on and off ramps, there are limited conflict points on the street. The project transportation analysis states, “Collision data was obtained from the Statewide Integrated Traffic Records System (SWITRS) for Templeton CHP and City police on Theatre Drive in the vicinity of the project between 2017 and 2021. One injury collision occurred near Ranch Paso Road when a bicycle was traveling the wrong way. No collisions occurred at or near Nutwood Circle. There are no observed collision patterns and no recommendations.”</p> <p>The project is expected to add 178 daily trips, 41 in the peak morning hour and 45 in the peak PM hour, which is a less than significant impact consistent with the City’s 2022 Transportation Impact Analysis Guidelines.</p>	<input type="checkbox"/>	<input type="checkbox"/>	<input checked="" type="checkbox"/>	<input type="checkbox"/>
<p>d. Result in inadequate emergency access?</p> <p>Discussion: The project has been reviewed by the City’s Department of Emergency Services. The project will not impede emergency access, and is designed in compliance with all emergency access safety features and to City emergency access standards.</p>	<input type="checkbox"/>	<input type="checkbox"/>	<input type="checkbox"/>	<input checked="" type="checkbox"/>

XVIII. TRIBAL CULTURAL RESOURCES

<p>a. Would the project cause a substantial adverse change in the significance of a tribal cultural resource, defined in Public Resources Code § 21074 as either a site, feature, place, cultural landscape that is geographically defined in terms of the size and scope of the landscape, sacred place, or object with cultural value to a California Native American tribe, and that is:</p>	<input type="checkbox"/>	<input type="checkbox"/>	<input type="checkbox"/>	<input checked="" type="checkbox"/>
<p>i) Listed or eligible for listing in the California Register of Historical Resources, or in a local register of historical resources as defined in Public Resources Code section 5020.1(k), or</p>	<input type="checkbox"/>	<input type="checkbox"/>	<input type="checkbox"/>	<input checked="" type="checkbox"/>
<p>ii) A resource determined by the lead agency, in its discretion and supported by</p>	<input type="checkbox"/>	<input type="checkbox"/>	<input type="checkbox"/>	<input checked="" type="checkbox"/>

Potentially
Significant
Impact

Less Than
Significant
with
Mitigation
Incorporated

Less Than
Significant
Impact

Impact

substantial evidence, to be significant pursuant to criteria set forth in subdivision (c) of Public Resources Code § 5024.1. In applying the criteria set forth in subdivision (c) of Public Resource Code § 5024.1, the lead agency shall consider the significance of the resource to a California Native American tribe.

Discussion: No Tribal Cultural Resources were identified during an onsite survey of the site, nor in archival research conducted in support of the preparation of a cultural resources inventory survey for the site (Attachment 5).



XIX. UTILITIES AND SERVICE SYSTEMS: Would the project:

- a. Require or result in the relocation or construction of new or expanded water, wastewater treatment or storm water drainage, electric power, natural gas, or telecommunications facilities, the construction or relocation of which could cause significant environmental effects?

Discussion: The project will have an incremental but individually insignificant impact on listed utilities. Local planning for sewer and water utilities has anticipated a buildout for Paso Robles that includes commercial development on this site.

- b. Have sufficient water supplies available to serve the project and reasonably foreseeable future development during normal, dry and multiple dry years?

Discussion: The project site is within the City limits and it is zoned to allow for commercial development. Local planning for water supplies for buildout of the City include commercial development on the site. The proposed use is not a substantial user of water.

The City's municipal water supply is composed of groundwater from the Paso Robles Groundwater Basin, an allocation of the Salinas River underflow, and a surface water allocation from the Nacimiento Lake pipeline project. The 2015 Urban Water Management Plan (UWMP)⁵ indicates there is adequate capacity to serve all households and commercial users at build out. Water use for this project has been accounted for and therefore impacts to groundwater supplies are less than significant.

- c. Result in a determination by the wastewater treatment provider, which serves or may serve the project that it has adequate capacity to serve the project's projected demand in addition to the provider's existing commitments?

Discussion: The project is not a significant water user or wastewater producer; no significant increase in

Potentially
Significant
Impact

Less Than
Significant
with
Mitigation
Incorporated

Less Than
Significant
Impact

Impact

wastewater production is expected. The City's Sewer System Management Plan (SSMP)⁶ identifies system upgrades needed to accommodate buildout of the city. Development impact fees and sewer rates are adopted to address the proportionate share of impact of each development project on the sewer system.

- d. Generate solid waste in excess of state or local standards, or in excess of the capacity of local infrastructure, or otherwise impair the attainment of solid waste reduction goals?

Discussion: The City's Landfill Master Plan²¹ indicates the City's landfill has adequate capacity for all projected waste generated within the city until at least 2051. Both construction and residential wastes are subject to diversion requirements for recyclable and compostable materials. The project will not impair the city's ability to attain solid waste reduction goals.

- e. Comply with federal, state, and local management and reduction statutes and regulations related to solid waste?

Discussion: The proposed project will be required to comply with federal, state, and local management and reduction statutes and regulations.

XX. WILDFIRE. If located in or near state responsibility areas or lands classified as very high fire hazard severity zones, would the project:

- a. Substantially impair an adopted emergency response plan or emergency evacuation plan?
- b. Due to slope, prevailing winds, and other factors, exacerbate wildfire risks, and thereby expose project occupants to pollutant concentrations from a wildfire or the uncontrolled spread of a wildfire?
- c. Require the installation or maintenance of associated infrastructure (such as roads, fuel breaks, emergency water sources, power lines or other utilities) that may exacerbate fire risk or that may result in temporary or ongoing impacts to the environment?
- d. Expose people or structures to significant risks, including downslope or downstream flooding or landslides, as a result of runoff, post-fire slope instability, or drainage changes?

Discussion: The project is not near a state responsibility area or lands classified as very high fire hazard severity zone. The site is near the boundary of the City, but is surrounded by urban uses.

Potentially
Significant
Impact

Less Than
Significant
with
Mitigation
Incorporated

Less Than
Significant
Impact

Impact

XXI. MANDATORY FINDINGS OF SIGNIFICANCE

- a. Does the project have the potential to degrade the quality of the environment, substantially reduce the habitat of a fish or wildlife species, cause a fish or wildlife population to drop below self-sustaining levels, threaten to eliminate a plant or animal community, reduce the number or restrict the range of a rare or endangered plant or animal or eliminate important examples of the major periods of California history or prehistory?

Discussion: The project is located on an infill site. The project would continue the development pattern established on adjacent properties to the north. The site does not support significant habitat or contribute a migration corridor. The site does not contain significant historical resources or known tribal resources.

- b. Does the project have impacts that are individually limited, but cumulatively considerable? ("Cumulatively considerable" means that the incremental effects of a project are considerable when viewed in connection with the effects of past projects, the effects of other current projects, and the effects of probable future projects)?

Discussion: The project is located within the City's limits, where development has the least potential for significant impacts to the environment. The project will not induce additional development or future projects that would have a significant impact.

- c. Does the project have environmental effects which will cause substantial adverse effects on human beings, either directly or indirectly?

Discussion: While vehicle repair does include the handling of some hazardous substances, with mitigation it will have a less than significant impact on humans.

Attachment 9

EARLIER ANALYSIS AND BACKGROUND MATERIALS.

Earlier analyses may be used where, pursuant to tiering, program EIR, or other CEQA process, one or more effects have been adequately analyzed in an earlier EIR or negative declaration. Section 15063 (c)(3)(D).

Documents utilized in this analysis and background / explanatory materials:

<u>Reference #</u>	<u>Document Title</u>	<u>Available for Review at:</u>
1	City of Paso Robles General Plan	City of Paso Robles Community Development Department 1000 Spring Street Paso Robles, CA 93446 https://www.prcity.com/313/General-Plan
2	City of Paso Robles Environmental Impact Report for General Plan Update	City of Paso Robles
3	2007 Airport Land Use Plan	https://www.prcity.com/354/Airport-Land-Use-Plan
4	City of Paso Robles Municipal Code	https://library.municode.com/ca/el_paso_de_robles/codes/code_of_ordinances
5	City of Paso Robles Urban Water Management Plan 2016	City of Paso Robles https://www.prcity.com/DocumentCenter/View/14827/Urban-Water-Management-Plan-PDF
6	City of Paso Robles Sewer System Management Plan	City of Paso Robles https://www.prcity.com/DocumentCenter/View/15356/Sewer-System-Management-Plan-PDF?bidId=
7	City of Paso Robles Standard Conditions of Approval for New Development	City of Paso Robles
8	City of Paso Robles Gateway Plan: Design Standards, 2008	https://www.prcity.com/DocumentCenter/View/14730/Gateway-Plan-Design-Standards-PDF?bidId=
9	San Luis Obispo County Air Pollution Control District Guidelines for Impact Thresholds	https://www.slcleanair.org/rules-regulations/land-use-ceqa.php
10	USDA, Natural Resources Conservation Service,	NRCS Offices

Attachment 9

	Soil Survey of San Luis Obispo County, Paso Robles Area, 1983	Templeton, CA 93446 https://websoilsurvey.nrcs.usda.gov/app/WebSoilSurvey.aspx
11	Regional Transportation Plan, San Luis Obispo Council of Governments, 2019	https://slocog.org/2019RTP
12	Farmland Mapping and Monitoring Program California Resources Agency	https://www.conservation.ca.gov/dlrp/fmmp
13	Siting, Design, Operation and Maintenance of Onsite Wastewater Treatments Systems (OWTS) Policy California Water Boards	https://www.waterboards.ca.gov/water_issues/programs/owts/
14	Underground Storage Tank Program California Water Boards	https://www.waterboards.ca.gov/water_issues/programs/ust/
15	Water Quality Control Plan for the Central Coast Basin Central Coast Regional Water Quality Control Board	https://www.waterboards.ca.gov/centralcoast/publications_forms/publications/basin_plan/#:~:text=The%20Water%20Quality%20Control%20Plan,incloding%20surface%20waters%20and%20groundwater.
16	Post-Construction Stormwater Management Requirements for Development Projects in the Central Coast Central Coast Regional Water Quality Control Board	https://www.waterboards.ca.gov/centralcoast/water_issues/programs/stormwater/docs/lid/lid_hydromod_charette_index.html
17	Cortese List California Department of Toxic Substance Control	https://www.envirostor.dtsc.ca.gov/public/map/
18	Paso Robles Groundwater Basin Management Plan City of Paso Robles	https://www.prcity.com/DocumentCenter/View/15348/Groundwater-Basin-Management-Plan-PDF?bidId=
19	Purple Belt Plan City of Paso Robles	https://www.prcity.com/DocumentCenter/View/31945/Purple-Belt-Plan-PDF
20	Busch, Lawrence L. and Miller, Russel V. 2011. Updated Mineral Land Classification Map for the Concrete-Grade Aggregates in the San Luis Obispo-Santa Barbara Production- Consumption Region, California – North Half.	
21	Master Plan of Sustainable Opportunities at the Paso Robles Landfill City of Paso Robles	https://www.prcity.com/DocumentCenter/View/15350/Landfill-Master-Plan-PDF?bidId=

Attachment 9

Attachments:

1. Vicinity Map
2. Project Plans
3. CalEEmod Report
4. Biological Resources Assessment Report
5. Cultural Resources Inventory Survey
6. Transportation Analysis
7. Environmental Noise Assessment
8. Mitigation Monitoring and Reporting Plan

Attachment 9

Attachment 1 Vicinity Map

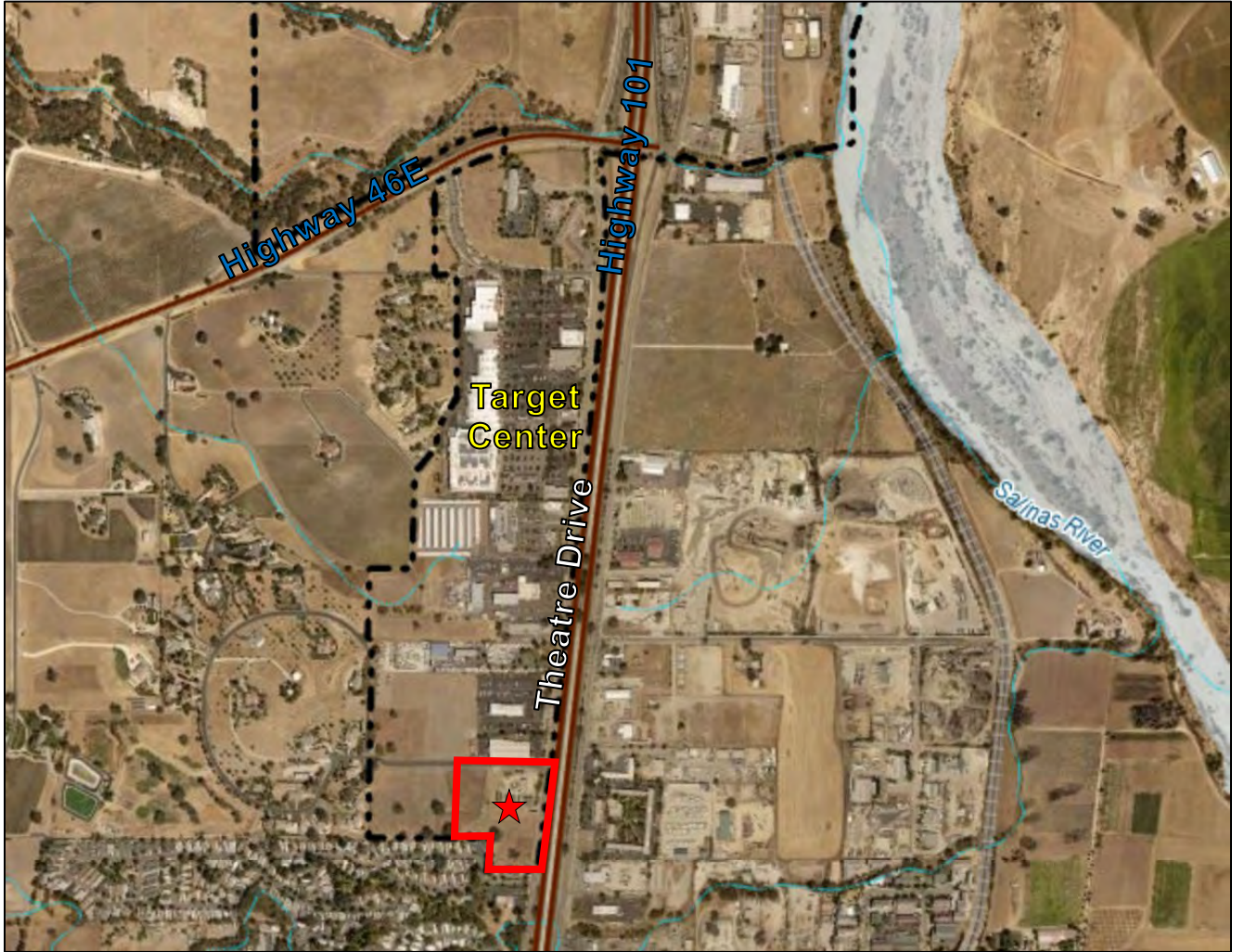

Peterbilt v2 Detailed Report

Table of Contents

- 1. Basic Project Information
 - 1.1. Basic Project Information
 - 1.2. Land Use Types
 - 1.3. User-Selected Emission Reduction Measures by Emissions Sector
- 2. Emissions Summary
 - 2.1. Construction Emissions Compared Against Thresholds
 - 2.2. Construction Emissions by Year, Unmitigated
 - 2.3. Construction Emissions by Year, Mitigated
 - 2.4. Operations Emissions Compared Against Thresholds
 - 2.5. Operations Emissions by Sector, Unmitigated
 - 2.6. Operations Emissions by Sector, Mitigated
- 3. Construction Emissions Details
 - 3.1. Site Preparation (2023) - Unmitigated
 - 3.2. Site Preparation (2023) - Mitigated

Attachment 9

3.3. Grading (2023) - Unmitigated

3.4. Grading (2023) - Mitigated

3.5. Building Construction (2023) - Unmitigated

3.6. Building Construction (2023) - Mitigated

3.7. Building Construction (2024) - Unmitigated

3.8. Building Construction (2024) - Mitigated

3.9. Paving (2024) - Unmitigated

3.10. Paving (2024) - Mitigated

3.11. Architectural Coating (2024) - Unmitigated

3.12. Architectural Coating (2024) - Mitigated

4. Operations Emissions Details

4.1. Mobile Emissions by Land Use

4.1.1. Unmitigated

4.1.2. Mitigated

4.2. Energy

4.2.1. Electricity Emissions By Land Use - Unmitigated

4.2.2. Electricity Emissions By Land Use - Mitigated

Attachment 9

4.2.3. Natural Gas Emissions By Land Use - Unmitigated

4.2.4. Natural Gas Emissions By Land Use - Mitigated

4.3. Area Emissions by Source

4.3.2. Unmitigated

4.3.1. Mitigated

4.4. Water Emissions by Land Use

4.4.2. Unmitigated

4.4.1. Mitigated

4.5. Waste Emissions by Land Use

4.5.2. Unmitigated

4.5.1. Mitigated

4.6. Refrigerant Emissions by Land Use

4.6.1. Unmitigated

4.6.2. Mitigated

4.7. Offroad Emissions By Equipment Type

4.7.1. Unmitigated

4.7.2. Mitigated

4.8. Stationary Emissions By Equipment Type

4.8.1. Unmitigated

4.8.2. Mitigated

4.9. User Defined Emissions By Equipment Type

4.9.1. Unmitigated

4.9.2. Mitigated

4.10. Soil Carbon Accumulation By Vegetation Type

4.10.1. Soil Carbon Accumulation By Vegetation Type - Unmitigated

4.10.2. Above and Belowground Carbon Accumulation by Land Use Type - Unmitigated

4.10.3. Avoided and Sequestered Emissions by Species - Unmitigated

4.10.4. Soil Carbon Accumulation By Vegetation Type - Mitigated

4.10.5. Above and Belowground Carbon Accumulation by Land Use Type - Mitigated

4.10.6. Avoided and Sequestered Emissions by Species - Mitigated

5. Activity Data

5.1. Construction Schedule

5.2. Off-Road Equipment

5.2.1. Unmitigated

5.2.2. Mitigated

5.3. Construction Vehicles

5.3.1. Unmitigated

5.3.2. Mitigated

5.4. Vehicles

5.4.1. Construction Vehicle Control Strategies

5.5. Architectural Coatings

5.6. Dust Mitigation

5.6.1. Construction Earthmoving Activities

5.6.2. Construction Earthmoving Control Strategies

5.7. Construction Paving

5.8. Construction Electricity Consumption and Emissions Factors

5.9. Operational Mobile Sources

5.9.1. Unmitigated

5.9.2. Mitigated

5.10. Operational Area Sources

5.10.1. Hearths

Attachment 9

5.10.1.1. Unmitigated

5.10.1.2. Mitigated

5.10.2. Architectural Coatings

5.10.3. Landscape Equipment

5.10.4. Landscape Equipment - Mitigated

5.11. Operational Energy Consumption

5.11.1. Unmitigated

5.11.2. Mitigated

5.12. Operational Water and Wastewater Consumption

5.12.1. Unmitigated

5.12.2. Mitigated

5.13. Operational Waste Generation

5.13.1. Unmitigated

5.13.2. Mitigated

5.14. Operational Refrigeration and Air Conditioning Equipment

5.14.1. Unmitigated

5.14.2. Mitigated

5.15. Operational Off-Road Equipment

5.15.1. Unmitigated

5.15.2. Mitigated

5.16. Stationary Sources

5.16.1. Emergency Generators and Fire Pumps

5.16.2. Process Boilers

5.17. User Defined

5.18. Vegetation

5.18.1. Land Use Change

5.18.1.1. Unmitigated

5.18.1.2. Mitigated

5.18.1. Biomass Cover Type

5.18.1.1. Unmitigated

5.18.1.2. Mitigated

5.18.2. Sequestration

5.18.2.1. Unmitigated

5.18.2.2. Mitigated

Attachment 9

- 6. Climate Risk Detailed Report
 - 6.1. Climate Risk Summary
 - 6.2. Initial Climate Risk Scores
 - 6.3. Adjusted Climate Risk Scores
 - 6.4. Climate Risk Reduction Measures
 - 6.4.1. Wildfire
 - 6.4.2. Drought
- 7. Health and Equity Details
 - 7.1. CalEnviroScreen 4.0 Scores
 - 7.2. Healthy Places Index Scores
 - 7.3. Overall Health & Equity Scores
 - 7.4. Health & Equity Measures
 - 7.5. Evaluation Scorecard
- 8. User Changes to Default Data

1. Basic Project Information

1.1. Basic Project Information

Data Field	Value
Project Name	Peterbilt v2
Lead Agency	—
Land Use Scale	Project/site
Analysis Level for Defaults	County
Windspeed (m/s)	3.00
Precipitation (days)	15.6
Location	35.57808909727966, -120.69854418153587
County	San Luis Obispo
City	Paso Robles
Air District	San Luis Obispo County APCD
Air Basin	South Central Coast
TAZ	3309
EDFZ	6
Electric Utility	Pacific Gas & Electric Company
Gas Utility	Southern California Gas

1.2. Land Use Types

Land Use Subtype	Size	Unit	Lot Acreage	Building Area (sq ft)	Landscape Area (sq ft)	Special Landscape Area (sq ft)	Population	Description
General Light Industry	11.0	1000sqft	0.25	11,000	40,394	—	—	Truck service
Automobile Care Center	14.0	1000sqft	0.32	14,000	1.00	—	—	Sales

Parking Lot	3.00	Acre	3.00	0.00	1.00	—	—	Parking
-------------	------	------	------	------	------	---	---	---------

1.3. User-Selected Emission Reduction Measures by Emissions Sector

Sector	#	Measure Title
Construction	C-2*	Limit Heavy-Duty Diesel Vehicle Idling
Construction	C-10-A	Water Exposed Surfaces
Construction	C-10-C	Water Unpaved Construction Roads
Construction	C-11	Limit Vehicle Speeds on Unpaved Roads
Construction	C-12	Sweep Paved Roads
Transportation	T-33*	Locate Project near Bike Path/Bike Lane
Water	W-5	Design Water-Efficient Landscapes
Natural	N-2	Expand Urban Tree Planting

* Qualitative or supporting measure. Emission reductions not included in the mitigated emissions results.

2. Emissions Summary

2.1. Construction Emissions Compared Against Thresholds

Criteria Pollutants (lb/day for daily, ton/yr for annual) and GHGs (lb/day for daily, MT/yr for annual)

Un/Mit.	TOG	ROG	NOx	CO	SO2	PM10E	PM10D	PM10T	PM2.5E	PM2.5D	PM2.5T	BCO2	NBCO2	CO2T	CH4	N2O	R	CO2e
Daily, Summer (Max)	—	—	—	—	—	—	—	—	—	—	—	—	—	—	—	—	—	—
Unmit.	4.78	40.4	39.8	36.1	0.06	1.81	2.76	3.75	1.66	0.51	1.68	—	5,778	5,778	0.27	0.47	5.62	5,929
Mit.	4.78	40.4	39.8	36.1	0.06	1.81	2.76	3.75	1.66	0.51	1.68	—	5,778	5,778	0.27	0.47	5.62	5,929
% Reduced	—	—	—	—	—	—	—	—	—	—	—	—	—	—	—	—	—	—
Daily, Winter (Max)	—	—	—	—	—	—	—	—	—	—	—	—	—	—	—	—	—	—

Attachment 9

Unmit.	1.56	1.30	12.0	13.6	0.02	0.55	0.08	0.63	0.51	0.02	0.53	—	2,548	2,548	0.10	0.04	0.01	2,561
Mit.	1.56	1.30	12.0	13.6	0.02	0.55	0.08	0.63	0.51	0.02	0.53	—	2,548	2,548	0.10	0.04	0.01	2,561
% Reduced	—	—	—	—	—	—	—	—	—	—	—	—	—	—	—	—	—	—
Average Daily (Max)	—	—	—	—	—	—	—	—	—	—	—	—	—	—	—	—	—	—
Unmit.	0.69	2.59	5.27	6.31	0.01	0.23	0.08	0.27	0.21	0.02	0.22	—	1,171	1,171	0.05	0.02	0.10	1,177
Mit.	0.69	2.59	5.27	6.31	0.01	0.23	0.08	0.27	0.21	0.02	0.22	—	1,171	1,171	0.05	0.02	0.10	1,177
% Reduced	—	—	—	—	—	—	—	—	—	—	—	—	—	—	—	—	—	—
Annual (Max)	—	—	—	—	—	—	—	—	—	—	—	—	—	—	—	—	—	—
Unmit.	0.13	0.47	0.96	1.15	< 0.005	0.04	0.01	0.05	0.04	< 0.005	0.04	—	194	194	0.01	< 0.005	0.02	195
Mit.	0.13	0.47	0.96	1.15	< 0.005	0.04	0.01	0.05	0.04	< 0.005	0.04	—	194	194	0.01	< 0.005	0.02	195
% Reduced	—	—	—	—	—	—	—	—	—	—	—	—	—	—	—	—	—	—

2.2. Construction Emissions by Year, Unmitigated

Criteria Pollutants (lb/day for daily, ton/yr for annual) and GHGs (lb/day for daily, MT/yr for annual)

Year	TOG	ROG	NOx	CO	SO2	PM10E	PM10D	PM10T	PM2.5E	PM2.5D	PM2.5T	BCO2	NBCO2	CO2T	CH4	N2O	R	CO2e
Daily - Summer (Max)	—	—	—	—	—	—	—	—	—	—	—	—	—	—	—	—	—	—
2023	4.78	4.03	39.8	36.1	0.06	1.81	2.76	3.75	1.66	0.51	1.68	—	5,778	5,778	0.27	0.47	5.62	5,929
2024	1.49	40.4	11.4	13.5	0.02	0.50	0.11	0.57	0.46	0.03	0.48	—	2,548	2,548	0.10	0.04	0.55	2,562
Daily - Winter (Max)	—	—	—	—	—	—	—	—	—	—	—	—	—	—	—	—	—	—
2023	1.56	1.30	12.0	13.6	0.02	0.55	0.08	0.63	0.51	0.02	0.53	—	2,548	2,548	0.10	0.04	0.01	2,561
2024	1.49	1.24	11.4	13.5	0.02	0.50	0.08	0.57	0.46	0.02	0.48	—	2,546	2,546	0.10	0.04	0.01	2,559

Attachment 9

Average Daily	—	—	—	—	—	—	—	—	—	—	—	—	—	—	—	—	—	—
2023	0.44	0.37	3.52	3.73	0.01	0.16	0.08	0.24	0.15	0.02	0.16	—	719	719	0.03	0.02	0.10	725
2024	0.69	2.59	5.27	6.31	0.01	0.23	0.04	0.27	0.21	0.01	0.22	—	1,171	1,171	0.05	0.02	0.10	1,177
Annual	—	—	—	—	—	—	—	—	—	—	—	—	—	—	—	—	—	—
2023	0.08	0.07	0.64	0.68	< 0.005	0.03	0.01	0.04	0.03	< 0.005	0.03	—	119	119	< 0.005	< 0.005	0.02	120
2024	0.13	0.47	0.96	1.15	< 0.005	0.04	0.01	0.05	0.04	< 0.005	0.04	—	194	194	0.01	< 0.005	0.02	195

2.3. Construction Emissions by Year, Mitigated

Criteria Pollutants (lb/day for daily, ton/yr for annual) and GHGs (lb/day for daily, MT/yr for annual)

Year	TOG	ROG	NOx	CO	SO2	PM10E	PM10D	PM10T	PM2.5E	PM2.5D	PM2.5T	BCO2	NBCO2	CO2T	CH4	N2O	R	CO2e
Daily - Summer (Max)	—	—	—	—	—	—	—	—	—	—	—	—	—	—	—	—	—	—
2023	4.78	4.03	39.8	36.1	0.06	1.81	2.76	3.75	1.66	0.51	1.68	—	5,778	5,778	0.27	0.47	5.62	5,929
2024	1.49	40.4	11.4	13.5	0.02	0.50	0.11	0.57	0.46	0.03	0.48	—	2,548	2,548	0.10	0.04	0.55	2,562
Daily - Winter (Max)	—	—	—	—	—	—	—	—	—	—	—	—	—	—	—	—	—	—
2023	1.56	1.30	12.0	13.6	0.02	0.55	0.08	0.63	0.51	0.02	0.53	—	2,548	2,548	0.10	0.04	0.01	2,561
2024	1.49	1.24	11.4	13.5	0.02	0.50	0.08	0.57	0.46	0.02	0.48	—	2,546	2,546	0.10	0.04	0.01	2,559
Average Daily	—	—	—	—	—	—	—	—	—	—	—	—	—	—	—	—	—	—
2023	0.44	0.37	3.52	3.73	0.01	0.16	0.08	0.24	0.15	0.02	0.16	—	719	719	0.03	0.02	0.10	725
2024	0.69	2.59	5.27	6.31	0.01	0.23	0.04	0.27	0.21	0.01	0.22	—	1,171	1,171	0.05	0.02	0.10	1,177
Annual	—	—	—	—	—	—	—	—	—	—	—	—	—	—	—	—	—	—
2023	0.08	0.07	0.64	0.68	< 0.005	0.03	0.01	0.04	0.03	< 0.005	0.03	—	119	119	< 0.005	< 0.005	0.02	120
2024	0.13	0.47	0.96	1.15	< 0.005	0.04	0.01	0.05	0.04	< 0.005	0.04	—	194	194	0.01	< 0.005	0.02	195

2.4. Operations Emissions Compared Against Thresholds

Criteria Pollutants (lb/day for daily, ton/yr for annual) and GHGs (lb/day for daily, MT/yr for annual)

Un/Mit.	TOG	ROG	NOx	CO	SO2	PM10E	PM10D	PM10T	PM2.5E	PM2.5D	PM2.5T	BCO2	NBCO2	CO2T	CH4	N2O	R	CO2e
Daily, Summer (Max)	—	—	—	—	—	—	—	—	—	—	—	—	—	—	—	—	—	—
Unmit.	0.98	1.68	0.46	2.76	< 0.005	—	—	—	—	—	—	43.6	—	—	4.51	0.04	2,905	—
Mit.	0.98	1.68	0.46	2.76	< 0.005	—	—	—	—	—	—	43.6	—	—	4.51	0.04	2,905	—
% Reduced	—	—	—	—	—	—	—	—	—	—	—	—	—	—	—	—	—	—
Daily, Winter (Max)	—	—	—	—	—	—	—	—	—	—	—	—	—	—	—	—	—	—
Unmit.	0.76	1.47	0.47	2.04	< 0.005	—	—	—	—	—	—	43.6	—	—	4.51	0.04	2,905	—
Mit.	0.76	1.47	0.47	2.04	< 0.005	—	—	—	—	—	—	43.6	—	—	4.51	0.04	2,905	—
% Reduced	—	—	—	—	—	—	—	—	—	—	—	—	—	—	—	—	—	—
Average Daily (Max)	—	—	—	—	—	—	—	—	—	—	—	—	—	—	—	—	—	—
Unmit.	0.21	0.92	0.29	1.22	< 0.005	—	—	—	—	—	—	43.6	—	—	4.46	0.03	2,905	—
Mit.	0.21	0.92	0.29	1.22	< 0.005	—	—	—	—	—	—	43.6	—	—	4.46	0.03	2,905	—
% Reduced	—	—	—	—	—	—	—	—	—	—	—	—	—	—	—	—	—	—
Annual (Max)	—	—	—	—	—	—	—	—	—	—	—	—	—	—	—	—	—	—
Unmit.	0.04	0.17	0.05	0.22	< 0.005	—	—	—	—	—	—	7.21	—	—	0.74	< 0.005	481	—
Mit.	0.04	0.17	0.05	0.22	< 0.005	—	—	—	—	—	—	7.21	—	—	0.74	< 0.005	481	—
% Reduced	—	—	—	—	—	—	—	—	—	—	—	—	—	—	< 0.5%	< 0.5%	—	—

2.5. Operations Emissions by Sector, Unmitigated

Criteria Pollutants (lb/day for daily, ton/yr for annual) and GHGs (lb/day for daily, MT/yr for annual)

Sector	TOG	ROG	NOx	CO	SO2	PM10E	PM10D	PM10T	PM2.5E	PM2.5D	PM2.5T	BCO2	NBCO2	CO2T	CH4	N2O	R	CO2e
Daily, Summer (Max)	—	—	—	—	—	—	—	—	—	—	—	—	—	—	—	—	—	—
Mobile	0.75	0.74	0.17	1.43	< 0.005	< 0.005	0.01	0.01	< 0.005	< 0.005	< 0.005	—	64.9	64.9	0.03	0.01	0.15	70.2
Area	0.19	0.92	0.01	1.09	< 0.005	< 0.005	—	< 0.005	< 0.005	—	< 0.005	—	4.47	4.47	< 0.005	< 0.005	—	4.49
Energy	0.03	0.02	0.28	0.24	< 0.005	0.02	—	0.02	0.02	—	0.02	—	759	759	0.10	0.01	—	764
Water	—	—	—	—	—	—	—	—	—	—	—	7.40	12.9	20.3	0.76	0.02	—	44.7
Waste	—	—	—	—	—	—	—	—	—	—	—	36.2	0.00	36.2	3.62	0.00	—	127
Refrig.	—	—	—	—	—	—	—	—	—	—	—	—	—	—	—	—	2,905	2,905
Vegetation	—	—	—	—	—	NaN	NaN	NaN	NaN	NaN	NaN	—	NaN	NaN	—	—	—	NaN
Total	0.98	1.68	0.46	2.76	< 0.005	NaN	NaN	NaN	NaN	NaN	NaN	43.6	NaN	NaN	4.51	0.04	2,905	NaN
Daily, Winter (Max)	—	—	—	—	—	—	—	—	—	—	—	—	—	—	—	—	—	—
Mobile	0.73	0.71	0.19	1.81	< 0.005	< 0.005	0.01	0.01	< 0.005	< 0.005	< 0.005	—	64.6	64.6	0.04	0.02	< 0.005	70.4
Area	—	0.74	—	—	—	—	—	—	—	—	—	—	—	—	—	—	—	—
Energy	0.03	0.02	0.28	0.24	< 0.005	0.02	—	0.02	0.02	—	0.02	—	759	759	0.10	0.01	—	764
Water	—	—	—	—	—	—	—	—	—	—	—	7.40	12.9	20.3	0.76	0.02	—	44.7
Waste	—	—	—	—	—	—	—	—	—	—	—	36.2	0.00	36.2	3.62	0.00	—	127
Refrig.	—	—	—	—	—	—	—	—	—	—	—	—	—	—	—	—	2,905	2,905
Vegetation	—	—	—	—	—	NaN	NaN	NaN	NaN	NaN	NaN	—	NaN	NaN	—	—	—	NaN
Total	0.76	1.47	0.47	2.04	< 0.005	NaN	NaN	NaN	NaN	NaN	NaN	43.6	NaN	NaN	4.51	0.04	2,905	NaN
Average Daily	—	—	—	—	—	—	—	—	—	—	—	—	—	—	—	—	—	—

Attachment 9

Mobile	0.00	0.00	0.00	0.00	0.00	0.00	0.00	0.00	0.00	0.00	0.00	—	0.00	0.00	0.00	0.00	0.00	0.00
Area	0.17	0.91	0.01	0.98	< 0.005	< 0.005	—	< 0.005	< 0.005	—	< 0.005	—	4.04	4.04	< 0.005	< 0.005	—	4.06
Energy	0.03	0.02	0.28	0.24	< 0.005	0.02	—	0.02	0.02	—	0.02	—	697	697	0.09	0.01	—	701
Water	—	—	—	—	—	—	—	—	—	—	—	7.40	12.9	20.3	0.76	0.02	—	44.7
Waste	—	—	—	—	—	—	—	—	—	—	—	36.2	0.00	36.2	3.62	0.00	—	127
Refrig.	—	—	—	—	—	—	—	—	—	—	—	—	—	—	—	—	2,905	2,905
Vegetation	—	—	—	—	—	NaN	NaN	NaN	NaN	NaN	NaN	—	NaN	NaN	—	—	—	NaN
Total	0.21	0.92	0.29	1.22	< 0.005	NaN	NaN	NaN	NaN	NaN	NaN	43.6	NaN	NaN	4.46	0.03	2,905	NaN
Annual	—	—	—	—	—	—	—	—	—	—	—	—	—	—	—	—	—	—
Mobile	0.00	0.00	0.00	0.00	0.00	0.00	0.00	0.00	0.00	0.00	0.00	—	0.00	0.00	0.00	0.00	0.00	0.00
Area	0.03	0.17	< 0.005	0.18	< 0.005	< 0.005	—	< 0.005	< 0.005	—	< 0.005	—	0.67	0.67	< 0.005	< 0.005	—	0.67
Energy	0.01	< 0.005	0.05	0.04	< 0.005	< 0.005	—	< 0.005	< 0.005	—	< 0.005	—	115	115	0.01	< 0.005	—	116
Water	—	—	—	—	—	—	—	—	—	—	—	1.22	2.13	3.35	0.13	< 0.005	—	7.40
Waste	—	—	—	—	—	—	—	—	—	—	—	5.99	0.00	5.99	0.60	0.00	—	21.0
Refrig.	—	—	—	—	—	—	—	—	—	—	—	—	—	—	—	—	481	481
Vegetation	—	—	—	—	—	NaN	NaN	NaN	NaN	NaN	NaN	—	NaN	NaN	—	—	—	NaN
Total	0.04	0.17	0.05	0.22	< 0.005	NaN	NaN	NaN	NaN	NaN	NaN	7.21	NaN	NaN	0.74	< 0.005	481	NaN

2.6. Operations Emissions by Sector, Mitigated

Criteria Pollutants (lb/day for daily, ton/yr for annual) and GHGs (lb/day for daily, MT/yr for annual)

Sector	TOG	ROG	NOx	CO	SO2	PM10E	PM10D	PM10T	PM2.5E	PM2.5D	PM2.5T	BCO2	NBCO2	CO2T	CH4	N2O	R	CO2e
Daily, Summer (Max)	—	—	—	—	—	—	—	—	—	—	—	—	—	—	—	—	—	—
Mobile	0.75	0.74	0.17	1.43	< 0.005	< 0.005	0.01	0.01	< 0.005	< 0.005	< 0.005	—	64.9	64.9	0.03	0.01	0.15	70.2
Area	0.19	0.92	0.01	1.09	< 0.005	< 0.005	—	< 0.005	< 0.005	—	< 0.005	—	4.47	4.47	< 0.005	< 0.005	—	4.49
Energy	0.03	0.02	0.28	0.24	< 0.005	0.02	—	0.02	0.02	—	0.02	—	759	759	0.10	0.01	—	764

Attachment 9

Water	—	—	—	—	—	—	—	—	—	—	—	7.40	12.2	19.6	0.76	0.02	—	44.1
Waste	—	—	—	—	—	—	—	—	—	—	—	36.2	0.00	36.2	3.62	0.00	—	127
Refrig.	—	—	—	—	—	—	—	—	—	—	—	—	—	—	—	—	2,905	2,905
Vegetation	—	—	—	—	—	NaN	NaN	NaN	NaN	NaN	NaN	—	NaN	NaN	—	—	—	NaN
Total	0.98	1.68	0.46	2.76	< 0.005	NaN	NaN	NaN	NaN	NaN	NaN	43.6	NaN	NaN	4.51	0.04	2,905	NaN
Daily, Winter (Max)	—	—	—	—	—	—	—	—	—	—	—	—	—	—	—	—	—	—
Mobile	0.73	0.71	0.19	1.81	< 0.005	< 0.005	0.01	0.01	< 0.005	< 0.005	< 0.005	—	64.6	64.6	0.04	0.02	< 0.005	70.4
Area	—	0.74	—	—	—	—	—	—	—	—	—	—	—	—	—	—	—	—
Energy	0.03	0.02	0.28	0.24	< 0.005	0.02	—	0.02	0.02	—	0.02	—	759	759	0.10	0.01	—	764
Water	—	—	—	—	—	—	—	—	—	—	—	7.40	12.2	19.6	0.76	0.02	—	44.1
Waste	—	—	—	—	—	—	—	—	—	—	—	36.2	0.00	36.2	3.62	0.00	—	127
Refrig.	—	—	—	—	—	—	—	—	—	—	—	—	—	—	—	—	2,905	2,905
Vegetation	—	—	—	—	—	NaN	NaN	NaN	NaN	NaN	NaN	—	NaN	NaN	—	—	—	NaN
Total	0.76	1.47	0.47	2.04	< 0.005	NaN	NaN	NaN	NaN	NaN	NaN	43.6	NaN	NaN	4.51	0.04	2,905	NaN
Average Daily	—	—	—	—	—	—	—	—	—	—	—	—	—	—	—	—	—	—
Mobile	0.00	0.00	0.00	0.00	0.00	0.00	0.00	0.00	0.00	0.00	0.00	—	0.00	0.00	0.00	0.00	0.00	0.00
Area	0.17	0.91	0.01	0.98	< 0.005	< 0.005	—	< 0.005	< 0.005	—	< 0.005	—	4.04	4.04	< 0.005	< 0.005	—	4.06
Energy	0.03	0.02	0.28	0.24	< 0.005	0.02	—	0.02	0.02	—	0.02	—	697	697	0.09	0.01	—	701
Water	—	—	—	—	—	—	—	—	—	—	—	7.40	12.2	19.6	0.76	0.02	—	44.1
Waste	—	—	—	—	—	—	—	—	—	—	—	36.2	0.00	36.2	3.62	0.00	—	127
Refrig.	—	—	—	—	—	—	—	—	—	—	—	—	—	—	—	—	2,905	2,905
Vegetation	—	—	—	—	—	NaN	NaN	NaN	NaN	NaN	NaN	—	NaN	NaN	—	—	—	NaN
Total	0.21	0.92	0.29	1.22	< 0.005	NaN	NaN	NaN	NaN	NaN	NaN	43.6	NaN	NaN	4.46	0.03	2,905	NaN
Annual	—	—	—	—	—	—	—	—	—	—	—	—	—	—	—	—	—	—

Attachment 9

Mobile	0.00	0.00	0.00	0.00	0.00	0.00	0.00	0.00	0.00	0.00	0.00	—	0.00	0.00	0.00	0.00	0.00	0.00
Area	0.03	0.17	< 0.005	0.18	< 0.005	< 0.005	—	< 0.005	< 0.005	—	< 0.005	—	0.67	0.67	< 0.005	< 0.005	—	0.67
Energy	0.01	< 0.005	0.05	0.04	< 0.005	< 0.005	—	< 0.005	< 0.005	—	< 0.005	—	115	115	0.01	< 0.005	—	116
Water	—	—	—	—	—	—	—	—	—	—	—	1.22	2.02	3.25	0.13	< 0.005	—	7.30
Waste	—	—	—	—	—	—	—	—	—	—	—	5.99	0.00	5.99	0.60	0.00	—	21.0
Refrig.	—	—	—	—	—	—	—	—	—	—	—	—	—	—	—	—	481	481
Vegetation	—	—	—	—	—	NaN	NaN	NaN	NaN	NaN	NaN	—	NaN	NaN	—	—	—	NaN
Total	0.04	0.17	0.05	0.22	< 0.005	NaN	NaN	NaN	NaN	NaN	NaN	7.21	NaN	NaN	0.74	< 0.005	481	NaN

3. Construction Emissions Details

3.1. Site Preparation (2023) - Unmitigated

Criteria Pollutants (lb/day for daily, ton/yr for annual) and GHGs (lb/day for daily, MT/yr for annual)

Location	TOG	ROG	NOx	CO	SO2	PM10E	PM10D	PM10T	PM2.5E	PM2.5D	PM2.5T	BCO2	NBCO2	CO2T	CH4	N2O	R	CO2e
Onsite	—	—	—	—	—	—	—	—	—	—	—	—	—	—	—	—	—	—
Daily, Summer (Max)	—	—	—	—	—	—	—	—	—	—	—	—	—	—	—	—	—	—
Off-Road Equipment	4.70	3.95	39.7	35.5	0.05	1.81	—	1.81	1.66	—	1.66	—	5,295	5,295	0.21	0.04	—	5,314
Onsite truck	0.00	0.00	0.00	0.00	0.00	0.00	0.00	0.00	0.00	0.00	0.00	—	0.00	0.00	0.00	0.00	0.00	0.00
Daily, Winter (Max)	—	—	—	—	—	—	—	—	—	—	—	—	—	—	—	—	—	—
Average Daily	—	—	—	—	—	—	—	—	—	—	—	—	—	—	—	—	—	—
Off-Road Equipment	0.06	0.05	0.54	0.49	< 0.005	0.02	—	0.02	0.02	—	0.02	—	72.5	72.5	< 0.005	< 0.005	—	72.8

Attachment 9

Onsite truck	0.00	0.00	0.00	0.00	0.00	0.00	0.00	0.00	0.00	0.00	0.00	0.00	—	0.00	0.00	0.00	0.00	0.00	0.00
Annual	—	—	—	—	—	—	—	—	—	—	—	—	—	—	—	—	—	—	—
Off-Road Equipment	0.01	0.01	0.10	0.09	< 0.005	< 0.005	—	< 0.005	< 0.005	—	< 0.005	—	—	12.0	12.0	< 0.005	< 0.005	—	12.1
Onsite truck	0.00	0.00	0.00	0.00	0.00	0.00	0.00	0.00	0.00	0.00	0.00	0.00	—	0.00	0.00	0.00	0.00	0.00	0.00
Offsite	—	—	—	—	—	—	—	—	—	—	—	—	—	—	—	—	—	—	—
Daily, Summer (Max)	—	—	—	—	—	—	—	—	—	—	—	—	—	—	—	—	—	—	—
Worker	0.09	0.08	0.05	0.66	0.00	0.00	0.01	0.01	0.00	0.00	0.00	0.00	—	111	111	0.01	< 0.005	0.52	113
Vendor	0.00	0.00	0.00	0.00	0.00	0.00	0.00	0.00	0.00	0.00	0.00	0.00	—	0.00	0.00	0.00	0.00	0.00	0.00
Hauling	0.00	0.00	0.00	0.00	0.00	0.00	0.00	0.00	0.00	0.00	0.00	0.00	—	0.00	0.00	0.00	0.00	0.00	0.00
Daily, Winter (Max)	—	—	—	—	—	—	—	—	—	—	—	—	—	—	—	—	—	—	—
Average Daily	—	—	—	—	—	—	—	—	—	—	—	—	—	—	—	—	—	—	—
Worker	< 0.005	< 0.005	< 0.005	0.01	0.00	0.00	< 0.005	< 0.005	0.00	0.00	0.00	0.00	—	1.46	1.46	< 0.005	< 0.005	< 0.005	1.49
Vendor	0.00	0.00	0.00	0.00	0.00	0.00	0.00	0.00	0.00	0.00	0.00	0.00	—	0.00	0.00	0.00	0.00	0.00	0.00
Hauling	0.00	0.00	0.00	0.00	0.00	0.00	0.00	0.00	0.00	0.00	0.00	0.00	—	0.00	0.00	0.00	0.00	0.00	0.00
Annual	—	—	—	—	—	—	—	—	—	—	—	—	—	—	—	—	—	—	—
Worker	< 0.005	< 0.005	< 0.005	< 0.005	0.00	0.00	< 0.005	< 0.005	0.00	0.00	0.00	0.00	—	0.24	0.24	< 0.005	< 0.005	< 0.005	0.25
Vendor	0.00	0.00	0.00	0.00	0.00	0.00	0.00	0.00	0.00	0.00	0.00	0.00	—	0.00	0.00	0.00	0.00	0.00	0.00
Hauling	0.00	0.00	0.00	0.00	0.00	0.00	0.00	0.00	0.00	0.00	0.00	0.00	—	0.00	0.00	0.00	0.00	0.00	0.00

3.2. Site Preparation (2023) - Mitigated

Criteria Pollutants (lb/day for daily, ton/yr for annual) and GHGs (lb/day for daily, MT/yr for annual)

Location	TOG	ROG	NOx	CO	SO2	PM10E	PM10D	PM10T	PM2.5E	PM2.5D	PM2.5T	BCO2	NBCO2	CO2T	CH4	N2O	R	CO2e
----------	-----	-----	-----	----	-----	-------	-------	-------	--------	--------	--------	------	-------	------	-----	-----	---	------

Attachment 9

Onsite	—	—	—	—	—	—	—	—	—	—	—	—	—	—	—	—	—	—
Daily, Summer (Max)	—	—	—	—	—	—	—	—	—	—	—	—	—	—	—	—	—	—
Off-Road Equipment	4.70	3.95	39.7	35.5	0.05	1.81	—	1.81	1.66	—	1.66	—	5,295	5,295	0.21	0.04	—	5,314
Onsite truck	0.00	0.00	0.00	0.00	0.00	0.00	0.00	0.00	0.00	0.00	0.00	—	0.00	0.00	0.00	0.00	0.00	0.00
Daily, Winter (Max)	—	—	—	—	—	—	—	—	—	—	—	—	—	—	—	—	—	—
Average Daily	—	—	—	—	—	—	—	—	—	—	—	—	—	—	—	—	—	—
Off-Road Equipment	0.06	0.05	0.54	0.49	< 0.005	0.02	—	0.02	0.02	—	0.02	—	72.5	72.5	< 0.005	< 0.005	—	72.8
Onsite truck	0.00	0.00	0.00	0.00	0.00	0.00	0.00	0.00	0.00	0.00	0.00	—	0.00	0.00	0.00	0.00	0.00	0.00
Annual	—	—	—	—	—	—	—	—	—	—	—	—	—	—	—	—	—	—
Off-Road Equipment	0.01	0.01	0.10	0.09	< 0.005	< 0.005	—	< 0.005	< 0.005	—	< 0.005	—	12.0	12.0	< 0.005	< 0.005	—	12.1
Onsite truck	0.00	0.00	0.00	0.00	0.00	0.00	0.00	0.00	0.00	0.00	0.00	—	0.00	0.00	0.00	0.00	0.00	0.00
Offsite	—	—	—	—	—	—	—	—	—	—	—	—	—	—	—	—	—	—
Daily, Summer (Max)	—	—	—	—	—	—	—	—	—	—	—	—	—	—	—	—	—	—
Worker	0.09	0.08	0.05	0.66	0.00	0.00	0.01	0.01	0.00	0.00	0.00	—	111	111	0.01	< 0.005	0.52	113
Vendor	0.00	0.00	0.00	0.00	0.00	0.00	0.00	0.00	0.00	0.00	0.00	—	0.00	0.00	0.00	0.00	0.00	0.00
Hauling	0.00	0.00	0.00	0.00	0.00	0.00	0.00	0.00	0.00	0.00	0.00	—	0.00	0.00	0.00	0.00	0.00	0.00
Daily, Winter (Max)	—	—	—	—	—	—	—	—	—	—	—	—	—	—	—	—	—	—

Attachment 9

Average Daily	—	—	—	—	—	—	—	—	—	—	—	—	—	—	—	—	—	—
Worker	< 0.005	< 0.005	< 0.005	0.01	0.00	0.00	< 0.005	< 0.005	0.00	0.00	0.00	—	1.46	1.46	< 0.005	< 0.005	< 0.005	1.49
Vendor	0.00	0.00	0.00	0.00	0.00	0.00	0.00	0.00	0.00	0.00	0.00	—	0.00	0.00	0.00	0.00	0.00	0.00
Hauling	0.00	0.00	0.00	0.00	0.00	0.00	0.00	0.00	0.00	0.00	0.00	—	0.00	0.00	0.00	0.00	0.00	0.00
Annual	—	—	—	—	—	—	—	—	—	—	—	—	—	—	—	—	—	—
Worker	< 0.005	< 0.005	< 0.005	< 0.005	0.00	0.00	< 0.005	< 0.005	0.00	0.00	0.00	—	0.24	0.24	< 0.005	< 0.005	< 0.005	0.25
Vendor	0.00	0.00	0.00	0.00	0.00	0.00	0.00	0.00	0.00	0.00	0.00	—	0.00	0.00	0.00	0.00	0.00	0.00
Hauling	0.00	0.00	0.00	0.00	0.00	0.00	0.00	0.00	0.00	0.00	0.00	—	0.00	0.00	0.00	0.00	0.00	0.00

3.3. Grading (2023) - Unmitigated

Criteria Pollutants (lb/day for daily, ton/yr for annual) and GHGs (lb/day for daily, MT/yr for annual)

Location	TOG	ROG	NOx	CO	SO2	PM10E	PM10D	PM10T	PM2.5E	PM2.5D	PM2.5T	BCO2	NBCO2	CO2T	CH4	N2O	R	CO2e
Onsite	—	—	—	—	—	—	—	—	—	—	—	—	—	—	—	—	—	—
Daily, Summer (Max)	—	—	—	—	—	—	—	—	—	—	—	—	—	—	—	—	—	—
Off-Road Equipment	2.43	2.04	20.0	19.7	0.03	0.94	—	0.94	0.87	—	0.87	—	2,958	2,958	0.12	0.02	—	2,968
Demolition	—	—	—	—	—	—	2.02	2.02	—	0.31	0.31	—	—	—	—	—	—	—
Onsite truck	0.00	0.00	0.00	0.00	0.00	0.00	0.00	0.00	0.00	0.00	0.00	—	0.00	0.00	0.00	0.00	0.00	0.00
Daily, Winter (Max)	—	—	—	—	—	—	—	—	—	—	—	—	—	—	—	—	—	—
Average Daily	—	—	—	—	—	—	—	—	—	—	—	—	—	—	—	—	—	—
Off-Road Equipment	0.05	0.04	0.44	0.43	< 0.005	0.02	—	0.02	0.02	—	0.02	—	64.8	64.8	< 0.005	< 0.005	—	65.1

Attachment 9

Demolition	—	—	—	—	—	—	0.04	0.04	—	0.01	0.01	—	—	—	—	—	—	—
Onsite truck	0.00	0.00	0.00	0.00	0.00	0.00	0.00	0.00	0.00	0.00	0.00	—	0.00	0.00	0.00	0.00	0.00	0.00
Annual	—	—	—	—	—	—	—	—	—	—	—	—	—	—	—	—	—	—
Off-Road Equipment	0.01	0.01	0.08	0.08	< 0.005	< 0.005	—	< 0.005	< 0.005	—	< 0.005	—	10.7	10.7	< 0.005	< 0.005	—	10.8
Demolition	—	—	—	—	—	—	0.01	0.01	—	< 0.005	< 0.005	—	—	—	—	—	—	—
Onsite truck	0.00	0.00	0.00	0.00	0.00	0.00	0.00	0.00	0.00	0.00	0.00	—	0.00	0.00	0.00	0.00	0.00	0.00
Offsite	—	—	—	—	—	—	—	—	—	—	—	—	—	—	—	—	—	—
Daily, Summer (Max)	—	—	—	—	—	—	—	—	—	—	—	—	—	—	—	—	—	—
Worker	0.07	0.07	0.05	0.56	0.00	0.00	0.01	0.01	0.00	0.00	0.00	—	94.8	94.8	0.01	< 0.005	0.44	96.6
Vendor	0.00	0.00	0.00	0.00	0.00	0.00	0.00	0.00	0.00	0.00	0.00	—	0.00	0.00	0.00	0.00	0.00	0.00
Hauling	0.21	0.05	4.01	1.30	0.03	0.05	0.17	0.22	0.05	0.06	0.11	—	2,726	2,726	0.14	0.44	5.18	2,865
Daily, Winter (Max)	—	—	—	—	—	—	—	—	—	—	—	—	—	—	—	—	—	—
Average Daily	—	—	—	—	—	—	—	—	—	—	—	—	—	—	—	—	—	—
Worker	< 0.005	< 0.005	< 0.005	0.01	0.00	0.00	< 0.005	< 0.005	0.00	0.00	0.00	—	2.01	2.01	< 0.005	< 0.005	< 0.005	2.04
Vendor	0.00	0.00	0.00	0.00	0.00	0.00	0.00	0.00	0.00	0.00	0.00	—	0.00	0.00	0.00	0.00	0.00	0.00
Hauling	< 0.005	< 0.005	0.09	0.03	< 0.005	< 0.005	< 0.005	< 0.005	< 0.005	< 0.005	< 0.005	—	59.7	59.7	< 0.005	0.01	0.05	62.7
Annual	—	—	—	—	—	—	—	—	—	—	—	—	—	—	—	—	—	—
Worker	< 0.005	< 0.005	< 0.005	< 0.005	0.00	0.00	< 0.005	< 0.005	0.00	0.00	0.00	—	0.33	0.33	< 0.005	< 0.005	< 0.005	0.34
Vendor	0.00	0.00	0.00	0.00	0.00	0.00	0.00	0.00	0.00	0.00	0.00	—	0.00	0.00	0.00	0.00	0.00	0.00
Hauling	< 0.005	< 0.005	0.02	0.01	< 0.005	< 0.005	< 0.005	< 0.005	< 0.005	< 0.005	< 0.005	—	9.89	9.89	< 0.005	< 0.005	0.01	10.4

3.4. Grading (2023) - Mitigated

Criteria Pollutants (lb/day for daily, ton/yr for annual) and GHGs (lb/day for daily, MT/yr for annual)

Location	TOG	ROG	NOx	CO	SO2	PM10E	PM10D	PM10T	PM2.5E	PM2.5D	PM2.5T	BCO2	NBCO2	CO2T	CH4	N2O	R	CO2e
Onsite	—	—	—	—	—	—	—	—	—	—	—	—	—	—	—	—	—	—
Daily, Summer (Max)	—	—	—	—	—	—	—	—	—	—	—	—	—	—	—	—	—	—
Off-Road Equipment	2.43	2.04	20.0	19.7	0.03	0.94	—	0.94	0.87	—	0.87	—	2,958	2,958	0.12	0.02	—	2,968
Demolition	—	—	—	—	—	—	2.02	2.02	—	0.31	0.31	—	—	—	—	—	—	—
Onsite truck	0.00	0.00	0.00	0.00	0.00	0.00	0.00	0.00	0.00	0.00	0.00	—	0.00	0.00	0.00	0.00	0.00	0.00
Daily, Winter (Max)	—	—	—	—	—	—	—	—	—	—	—	—	—	—	—	—	—	—
Average Daily	—	—	—	—	—	—	—	—	—	—	—	—	—	—	—	—	—	—
Off-Road Equipment	0.05	0.04	0.44	0.43	< 0.005	0.02	—	0.02	0.02	—	0.02	—	64.8	64.8	< 0.005	< 0.005	—	65.1
Demolition	—	—	—	—	—	—	0.04	0.04	—	0.01	0.01	—	—	—	—	—	—	—
Onsite truck	0.00	0.00	0.00	0.00	0.00	0.00	0.00	0.00	0.00	0.00	0.00	—	0.00	0.00	0.00	0.00	0.00	0.00
Annual	—	—	—	—	—	—	—	—	—	—	—	—	—	—	—	—	—	—
Off-Road Equipment	0.01	0.01	0.08	0.08	< 0.005	< 0.005	—	< 0.005	< 0.005	—	< 0.005	—	10.7	10.7	< 0.005	< 0.005	—	10.8
Demolition	—	—	—	—	—	—	0.01	0.01	—	< 0.005	< 0.005	—	—	—	—	—	—	—
Onsite truck	0.00	0.00	0.00	0.00	0.00	0.00	0.00	0.00	0.00	0.00	0.00	—	0.00	0.00	0.00	0.00	0.00	0.00
Offsite	—	—	—	—	—	—	—	—	—	—	—	—	—	—	—	—	—	—

Attachment 9

Daily, Summer (Max)	—	—	—	—	—	—	—	—	—	—	—	—	—	—	—	—	—	—
Worker	0.07	0.07	0.05	0.56	0.00	0.00	0.01	0.01	0.00	0.00	0.00	—	94.8	94.8	0.01	< 0.005	0.44	96.6
Vendor	0.00	0.00	0.00	0.00	0.00	0.00	0.00	0.00	0.00	0.00	0.00	—	0.00	0.00	0.00	0.00	0.00	0.00
Hauling	0.21	0.05	4.01	1.30	0.03	0.05	0.17	0.22	0.05	0.06	0.11	—	2,726	2,726	0.14	0.44	5.18	2,865
Daily, Winter (Max)	—	—	—	—	—	—	—	—	—	—	—	—	—	—	—	—	—	—
Average Daily	—	—	—	—	—	—	—	—	—	—	—	—	—	—	—	—	—	—
Worker	< 0.005	< 0.005	< 0.005	0.01	0.00	0.00	< 0.005	< 0.005	0.00	0.00	0.00	—	2.01	2.01	< 0.005	< 0.005	< 0.005	2.04
Vendor	0.00	0.00	0.00	0.00	0.00	0.00	0.00	0.00	0.00	0.00	0.00	—	0.00	0.00	0.00	0.00	0.00	0.00
Hauling	< 0.005	< 0.005	0.09	0.03	< 0.005	< 0.005	< 0.005	< 0.005	< 0.005	< 0.005	< 0.005	—	59.7	59.7	< 0.005	0.01	0.05	62.7
Annual	—	—	—	—	—	—	—	—	—	—	—	—	—	—	—	—	—	—
Worker	< 0.005	< 0.005	< 0.005	< 0.005	0.00	0.00	< 0.005	< 0.005	0.00	0.00	0.00	—	0.33	0.33	< 0.005	< 0.005	< 0.005	0.34
Vendor	0.00	0.00	0.00	0.00	0.00	0.00	0.00	0.00	0.00	0.00	0.00	—	0.00	0.00	0.00	0.00	0.00	0.00
Hauling	< 0.005	< 0.005	0.02	0.01	< 0.005	< 0.005	< 0.005	< 0.005	< 0.005	< 0.005	< 0.005	—	9.89	9.89	< 0.005	< 0.005	0.01	10.4

3.5. Building Construction (2023) - Unmitigated

Criteria Pollutants (lb/day for daily, ton/yr for annual) and GHGs (lb/day for daily, MT/yr for annual)

Location	TOG	ROG	NOx	CO	SO2	PM10E	PM10D	PM10T	PM2.5E	PM2.5D	PM2.5T	BCO2	NBCO2	CO2T	CH4	N2O	R	CO2e
Onsite	—	—	—	—	—	—	—	—	—	—	—	—	—	—	—	—	—	—
Daily, Summer (Max)	—	—	—	—	—	—	—	—	—	—	—	—	—	—	—	—	—	—
Off-Road Equipment	1.50	1.26	11.8	13.2	0.02	0.55	—	0.55	0.51	—	0.51	—	2,397	2,397	0.10	0.02	—	2,406
Onsite truck	0.00	0.00	0.00	0.00	0.00	0.00	0.00	0.00	0.00	0.00	0.00	—	0.00	0.00	0.00	0.00	0.00	0.00

Attachment 9

Daily, Winter (Max)	—	—	—	—	—	—	—	—	—	—	—	—	—	—	—	—	—	—
Off-Road Equipment	1.50	1.26	11.8	13.2	0.02	0.55	—	0.55	0.51	—	0.51	—	2,397	2,397	0.10	0.02	—	2,406
Onsite truck	0.00	0.00	0.00	0.00	0.00	0.00	0.00	0.00	0.00	0.00	0.00	—	0.00	0.00	0.00	0.00	0.00	0.00
Average Daily	—	—	—	—	—	—	—	—	—	—	—	—	—	—	—	—	—	—
Off-Road Equipment	0.31	0.26	2.40	2.68	< 0.005	0.11	—	0.11	0.10	—	0.10	—	488	488	0.02	< 0.005	—	490
Onsite truck	0.00	0.00	0.00	0.00	0.00	0.00	0.00	0.00	0.00	0.00	0.00	—	0.00	0.00	0.00	0.00	0.00	0.00
Annual	—	—	—	—	—	—	—	—	—	—	—	—	—	—	—	—	—	—
Off-Road Equipment	0.06	0.05	0.44	0.49	< 0.005	0.02	—	0.02	0.02	—	0.02	—	80.8	80.8	< 0.005	< 0.005	—	81.1
Onsite truck	0.00	0.00	0.00	0.00	0.00	0.00	0.00	0.00	0.00	0.00	0.00	—	0.00	0.00	0.00	0.00	0.00	0.00
Offsite	—	—	—	—	—	—	—	—	—	—	—	—	—	—	—	—	—	—
Daily, Summer (Max)	—	—	—	—	—	—	—	—	—	—	—	—	—	—	—	—	—	—
Worker	0.04	0.04	0.03	0.34	0.00	0.00	< 0.005	< 0.005	0.00	0.00	0.00	—	57.5	57.5	< 0.005	< 0.005	0.27	58.6
Vendor	0.01	< 0.005	0.15	0.06	< 0.005	< 0.005	< 0.005	0.01	< 0.005	< 0.005	< 0.005	—	95.0	95.0	< 0.005	0.01	0.24	99.4
Hauling	0.00	0.00	0.00	0.00	0.00	0.00	0.00	0.00	0.00	0.00	0.00	—	0.00	0.00	0.00	0.00	0.00	0.00
Daily, Winter (Max)	—	—	—	—	—	—	—	—	—	—	—	—	—	—	—	—	—	—
Worker	0.04	0.04	0.03	0.33	0.00	0.00	< 0.005	< 0.005	0.00	0.00	0.00	—	55.1	55.1	< 0.005	< 0.005	0.01	56.0
Vendor	0.01	< 0.005	0.15	0.06	< 0.005	< 0.005	< 0.005	0.01	< 0.005	< 0.005	< 0.005	—	95.0	95.0	< 0.005	0.01	0.01	99.2
Hauling	0.00	0.00	0.00	0.00	0.00	0.00	0.00	0.00	0.00	0.00	0.00	—	0.00	0.00	0.00	0.00	0.00	0.00
Average Daily	—	—	—	—	—	—	—	—	—	—	—	—	—	—	—	—	—	—

Attachment 9

Worker	0.01	0.01	0.01	0.07	0.00	0.00	< 0.005	< 0.005	0.00	0.00	0.00	—	11.3	11.3	< 0.005	< 0.005	0.02	11.5
Vendor	< 0.005	< 0.005	0.03	0.01	< 0.005	< 0.005	< 0.005	< 0.005	< 0.005	< 0.005	< 0.005	—	19.3	19.3	< 0.005	< 0.005	0.02	20.2
Hauling	0.00	0.00	0.00	0.00	0.00	0.00	0.00	0.00	0.00	0.00	0.00	—	0.00	0.00	0.00	0.00	0.00	0.00
Annual	—	—	—	—	—	—	—	—	—	—	—	—	—	—	—	—	—	—
Worker	< 0.005	< 0.005	< 0.005	0.01	0.00	0.00	< 0.005	< 0.005	0.00	0.00	0.00	—	1.87	1.87	< 0.005	< 0.005	< 0.005	1.90
Vendor	< 0.005	< 0.005	0.01	< 0.005	< 0.005	< 0.005	< 0.005	< 0.005	< 0.005	< 0.005	< 0.005	—	3.20	3.20	< 0.005	< 0.005	< 0.005	3.35
Hauling	0.00	0.00	0.00	0.00	0.00	0.00	0.00	0.00	0.00	0.00	0.00	—	0.00	0.00	0.00	0.00	0.00	0.00

3.6. Building Construction (2023) - Mitigated

Criteria Pollutants (lb/day for daily, ton/yr for annual) and GHGs (lb/day for daily, MT/yr for annual)

Location	TOG	ROG	NOx	CO	SO2	PM10E	PM10D	PM10T	PM2.5E	PM2.5D	PM2.5T	BCO2	NBCO2	CO2T	CH4	N2O	R	CO2e
Onsite	—	—	—	—	—	—	—	—	—	—	—	—	—	—	—	—	—	—
Daily, Summer (Max)	—	—	—	—	—	—	—	—	—	—	—	—	—	—	—	—	—	—
Off-Road Equipment	1.50	1.26	11.8	13.2	0.02	0.55	—	0.55	0.51	—	0.51	—	2,397	2,397	0.10	0.02	—	2,406
Onsite truck	0.00	0.00	0.00	0.00	0.00	0.00	0.00	0.00	0.00	0.00	0.00	—	0.00	0.00	0.00	0.00	0.00	0.00
Daily, Winter (Max)	—	—	—	—	—	—	—	—	—	—	—	—	—	—	—	—	—	—
Off-Road Equipment	1.50	1.26	11.8	13.2	0.02	0.55	—	0.55	0.51	—	0.51	—	2,397	2,397	0.10	0.02	—	2,406
Onsite truck	0.00	0.00	0.00	0.00	0.00	0.00	0.00	0.00	0.00	0.00	0.00	—	0.00	0.00	0.00	0.00	0.00	0.00
Average Daily	—	—	—	—	—	—	—	—	—	—	—	—	—	—	—	—	—	—
Off-Road Equipment	0.31	0.26	2.40	2.68	< 0.005	0.11	—	0.11	0.10	—	0.10	—	488	488	0.02	< 0.005	—	490

Attachment 9

Onsite truck	0.00	0.00	0.00	0.00	0.00	0.00	0.00	0.00	0.00	0.00	0.00	0.00	—	0.00	0.00	0.00	0.00	0.00	0.00
Annual	—	—	—	—	—	—	—	—	—	—	—	—	—	—	—	—	—	—	—
Off-Road Equipment	0.06	0.05	0.44	0.49	< 0.005	0.02	—	0.02	0.02	—	0.02	—	80.8	80.8	< 0.005	< 0.005	—	81.1	
Onsite truck	0.00	0.00	0.00	0.00	0.00	0.00	0.00	0.00	0.00	0.00	0.00	—	0.00	0.00	0.00	0.00	0.00	0.00	0.00
Offsite	—	—	—	—	—	—	—	—	—	—	—	—	—	—	—	—	—	—	—
Daily, Summer (Max)	—	—	—	—	—	—	—	—	—	—	—	—	—	—	—	—	—	—	—
Worker	0.04	0.04	0.03	0.34	0.00	0.00	< 0.005	< 0.005	0.00	0.00	0.00	—	57.5	57.5	< 0.005	< 0.005	0.27	58.6	
Vendor	0.01	< 0.005	0.15	0.06	< 0.005	< 0.005	< 0.005	0.01	< 0.005	< 0.005	< 0.005	—	95.0	95.0	< 0.005	0.01	0.24	99.4	
Hauling	0.00	0.00	0.00	0.00	0.00	0.00	0.00	0.00	0.00	0.00	0.00	—	0.00	0.00	0.00	0.00	0.00	0.00	
Daily, Winter (Max)	—	—	—	—	—	—	—	—	—	—	—	—	—	—	—	—	—	—	—
Worker	0.04	0.04	0.03	0.33	0.00	0.00	< 0.005	< 0.005	0.00	0.00	0.00	—	55.1	55.1	< 0.005	< 0.005	0.01	56.0	
Vendor	0.01	< 0.005	0.15	0.06	< 0.005	< 0.005	< 0.005	0.01	< 0.005	< 0.005	< 0.005	—	95.0	95.0	< 0.005	0.01	0.01	99.2	
Hauling	0.00	0.00	0.00	0.00	0.00	0.00	0.00	0.00	0.00	0.00	0.00	—	0.00	0.00	0.00	0.00	0.00	0.00	
Average Daily	—	—	—	—	—	—	—	—	—	—	—	—	—	—	—	—	—	—	—
Worker	0.01	0.01	0.01	0.07	0.00	0.00	< 0.005	< 0.005	0.00	0.00	0.00	—	11.3	11.3	< 0.005	< 0.005	0.02	11.5	
Vendor	< 0.005	< 0.005	0.03	0.01	< 0.005	< 0.005	< 0.005	< 0.005	< 0.005	< 0.005	< 0.005	—	19.3	19.3	< 0.005	< 0.005	0.02	20.2	
Hauling	0.00	0.00	0.00	0.00	0.00	0.00	0.00	0.00	0.00	0.00	0.00	—	0.00	0.00	0.00	0.00	0.00	0.00	
Annual	—	—	—	—	—	—	—	—	—	—	—	—	—	—	—	—	—	—	—
Worker	< 0.005	< 0.005	< 0.005	0.01	0.00	0.00	< 0.005	< 0.005	0.00	0.00	0.00	—	1.87	1.87	< 0.005	< 0.005	< 0.005	1.90	
Vendor	< 0.005	< 0.005	0.01	< 0.005	< 0.005	< 0.005	< 0.005	< 0.005	< 0.005	< 0.005	< 0.005	—	3.20	3.20	< 0.005	< 0.005	< 0.005	3.35	
Hauling	0.00	0.00	0.00	0.00	0.00	0.00	0.00	0.00	0.00	0.00	0.00	—	0.00	0.00	0.00	0.00	0.00	0.00	

Attachment 9

3.7. Building Construction (2024) - Unmitigated

Criteria Pollutants (lb/day for daily, ton/yr for annual) and GHGs (lb/day for daily, MT/yr for annual)

Location	TOG	ROG	NOx	CO	SO2	PM10E	PM10D	PM10T	PM2.5E	PM2.5D	PM2.5T	BCO2	NBCO2	CO2T	CH4	N2O	R	CO2e
Onsite	—	—	—	—	—	—	—	—	—	—	—	—	—	—	—	—	—	—
Daily, Summer (Max)	—	—	—	—	—	—	—	—	—	—	—	—	—	—	—	—	—	—
Off-Road Equipment	1.44	1.20	11.2	13.1	0.02	0.50	—	0.50	0.46	—	0.46	—	2,398	2,398	0.10	0.02	—	2,406
Onsite truck	0.00	0.00	0.00	0.00	0.00	0.00	0.00	0.00	0.00	0.00	0.00	—	0.00	0.00	0.00	0.00	0.00	0.00
Daily, Winter (Max)	—	—	—	—	—	—	—	—	—	—	—	—	—	—	—	—	—	—
Off-Road Equipment	1.44	1.20	11.2	13.1	0.02	0.50	—	0.50	0.46	—	0.46	—	2,398	2,398	0.10	0.02	—	2,406
Onsite truck	0.00	0.00	0.00	0.00	0.00	0.00	0.00	0.00	0.00	0.00	0.00	—	0.00	0.00	0.00	0.00	0.00	0.00
Average Daily	—	—	—	—	—	—	—	—	—	—	—	—	—	—	—	—	—	—
Off-Road Equipment	0.62	0.52	4.81	5.62	0.01	0.21	—	0.21	0.20	—	0.20	—	1,028	1,028	0.04	0.01	—	1,031
Onsite truck	0.00	0.00	0.00	0.00	0.00	0.00	0.00	0.00	0.00	0.00	0.00	—	0.00	0.00	0.00	0.00	0.00	0.00
Annual	—	—	—	—	—	—	—	—	—	—	—	—	—	—	—	—	—	—
Off-Road Equipment	0.11	0.09	0.88	1.03	< 0.005	0.04	—	0.04	0.04	—	0.04	—	170	170	0.01	< 0.005	—	171
Onsite truck	0.00	0.00	0.00	0.00	0.00	0.00	0.00	0.00	0.00	0.00	0.00	—	0.00	0.00	0.00	0.00	0.00	0.00
Offsite	—	—	—	—	—	—	—	—	—	—	—	—	—	—	—	—	—	—

Attachment 9

Daily, Summer (Max)	—	—	—	—	—	—	—	—	—	—	—	—	—	—	—	—	—	—
Worker	0.04	0.04	0.03	0.32	0.00	0.00	< 0.005	< 0.005	0.00	0.00	0.00	—	56.5	56.5	< 0.005	< 0.005	0.25	57.6
Vendor	0.01	< 0.005	0.14	0.06	< 0.005	< 0.005	< 0.005	0.01	< 0.005	< 0.005	< 0.005	—	93.7	93.7	< 0.005	0.01	0.24	98.1
Hauling	0.00	0.00	0.00	0.00	0.00	0.00	0.00	0.00	0.00	0.00	0.00	—	0.00	0.00	0.00	0.00	0.00	0.00
Daily, Winter (Max)	—	—	—	—	—	—	—	—	—	—	—	—	—	—	—	—	—	—
Worker	0.04	0.04	0.03	0.31	0.00	0.00	< 0.005	< 0.005	0.00	0.00	0.00	—	54.2	54.2	< 0.005	< 0.005	0.01	55.0
Vendor	0.01	< 0.005	0.15	0.06	< 0.005	< 0.005	< 0.005	0.01	< 0.005	< 0.005	< 0.005	—	93.7	93.7	< 0.005	0.01	0.01	97.9
Hauling	0.00	0.00	0.00	0.00	0.00	0.00	0.00	0.00	0.00	0.00	0.00	—	0.00	0.00	0.00	0.00	0.00	0.00
Average Daily	—	—	—	—	—	—	—	—	—	—	—	—	—	—	—	—	—	—
Worker	0.02	0.02	0.01	0.13	0.00	0.00	< 0.005	< 0.005	0.00	0.00	0.00	—	23.4	23.4	< 0.005	< 0.005	0.05	23.8
Vendor	< 0.005	< 0.005	0.06	0.02	< 0.005	< 0.005	< 0.005	< 0.005	< 0.005	< 0.005	< 0.005	—	40.2	40.2	< 0.005	0.01	0.04	42.0
Hauling	0.00	0.00	0.00	0.00	0.00	0.00	0.00	0.00	0.00	0.00	0.00	—	0.00	0.00	0.00	0.00	0.00	0.00
Annual	—	—	—	—	—	—	—	—	—	—	—	—	—	—	—	—	—	—
Worker	< 0.005	< 0.005	< 0.005	0.02	0.00	0.00	< 0.005	< 0.005	0.00	0.00	0.00	—	3.87	3.87	< 0.005	< 0.005	0.01	3.94
Vendor	< 0.005	< 0.005	0.01	< 0.005	< 0.005	< 0.005	< 0.005	< 0.005	< 0.005	< 0.005	< 0.005	—	6.65	6.65	< 0.005	< 0.005	0.01	6.95
Hauling	0.00	0.00	0.00	0.00	0.00	0.00	0.00	0.00	0.00	0.00	0.00	—	0.00	0.00	0.00	0.00	0.00	0.00

3.8. Building Construction (2024) - Mitigated

Criteria Pollutants (lb/day for daily, ton/yr for annual) and GHGs (lb/day for daily, MT/yr for annual)

Location	TOG	ROG	NOx	CO	SO2	PM10E	PM10D	PM10T	PM2.5E	PM2.5D	PM2.5T	BCO2	NBCO2	CO2T	CH4	N2O	R	CO2e
Onsite	—	—	—	—	—	—	—	—	—	—	—	—	—	—	—	—	—	—
Daily, Summer (Max)	—	—	—	—	—	—	—	—	—	—	—	—	—	—	—	—	—	—

Attachment 9

Off-Road Equipment	1.44	1.20	11.2	13.1	0.02	0.50	—	0.50	0.46	—	0.46	—	2,398	2,398	0.10	0.02	—	2,406
Onsite truck	0.00	0.00	0.00	0.00	0.00	0.00	0.00	0.00	0.00	0.00	0.00	—	0.00	0.00	0.00	0.00	0.00	0.00
Daily, Winter (Max)	—	—	—	—	—	—	—	—	—	—	—	—	—	—	—	—	—	—
Off-Road Equipment	1.44	1.20	11.2	13.1	0.02	0.50	—	0.50	0.46	—	0.46	—	2,398	2,398	0.10	0.02	—	2,406
Onsite truck	0.00	0.00	0.00	0.00	0.00	0.00	0.00	0.00	0.00	0.00	0.00	—	0.00	0.00	0.00	0.00	0.00	0.00
Average Daily	—	—	—	—	—	—	—	—	—	—	—	—	—	—	—	—	—	—
Off-Road Equipment	0.62	0.52	4.81	5.62	0.01	0.21	—	0.21	0.20	—	0.20	—	1,028	1,028	0.04	0.01	—	1,031
Onsite truck	0.00	0.00	0.00	0.00	0.00	0.00	0.00	0.00	0.00	0.00	0.00	—	0.00	0.00	0.00	0.00	0.00	0.00
Annual	—	—	—	—	—	—	—	—	—	—	—	—	—	—	—	—	—	—
Off-Road Equipment	0.11	0.09	0.88	1.03	< 0.005	0.04	—	0.04	0.04	—	0.04	—	170	170	0.01	< 0.005	—	171
Onsite truck	0.00	0.00	0.00	0.00	0.00	0.00	0.00	0.00	0.00	0.00	0.00	—	0.00	0.00	0.00	0.00	0.00	0.00
Offsite	—	—	—	—	—	—	—	—	—	—	—	—	—	—	—	—	—	—
Daily, Summer (Max)	—	—	—	—	—	—	—	—	—	—	—	—	—	—	—	—	—	—
Worker	0.04	0.04	0.03	0.32	0.00	0.00	< 0.005	< 0.005	0.00	0.00	0.00	—	56.5	56.5	< 0.005	< 0.005	0.25	57.6
Vendor	0.01	< 0.005	0.14	0.06	< 0.005	< 0.005	< 0.005	0.01	< 0.005	< 0.005	< 0.005	—	93.7	93.7	< 0.005	0.01	0.24	98.1
Hauling	0.00	0.00	0.00	0.00	0.00	0.00	0.00	0.00	0.00	0.00	0.00	—	0.00	0.00	0.00	0.00	0.00	0.00
Daily, Winter (Max)	—	—	—	—	—	—	—	—	—	—	—	—	—	—	—	—	—	—
Worker	0.04	0.04	0.03	0.31	0.00	0.00	< 0.005	< 0.005	0.00	0.00	0.00	—	54.2	54.2	< 0.005	< 0.005	0.01	55.0

Attachment 9

Vendor	0.01	< 0.005	0.15	0.06	< 0.005	< 0.005	< 0.005	0.01	< 0.005	< 0.005	< 0.005	—	93.7	93.7	< 0.005	0.01	0.01	97.9
Hauling	0.00	0.00	0.00	0.00	0.00	0.00	0.00	0.00	0.00	0.00	0.00	—	0.00	0.00	0.00	0.00	0.00	0.00
Average Daily	—	—	—	—	—	—	—	—	—	—	—	—	—	—	—	—	—	—
Worker	0.02	0.02	0.01	0.13	0.00	0.00	< 0.005	< 0.005	0.00	0.00	0.00	—	23.4	23.4	< 0.005	< 0.005	0.05	23.8
Vendor	< 0.005	< 0.005	0.06	0.02	< 0.005	< 0.005	< 0.005	< 0.005	< 0.005	< 0.005	< 0.005	—	40.2	40.2	< 0.005	0.01	0.04	42.0
Hauling	0.00	0.00	0.00	0.00	0.00	0.00	0.00	0.00	0.00	0.00	0.00	—	0.00	0.00	0.00	0.00	0.00	0.00
Annual	—	—	—	—	—	—	—	—	—	—	—	—	—	—	—	—	—	—
Worker	< 0.005	< 0.005	< 0.005	0.02	0.00	0.00	< 0.005	< 0.005	0.00	0.00	0.00	—	3.87	3.87	< 0.005	< 0.005	0.01	3.94
Vendor	< 0.005	< 0.005	0.01	< 0.005	< 0.005	< 0.005	< 0.005	< 0.005	< 0.005	< 0.005	< 0.005	—	6.65	6.65	< 0.005	< 0.005	0.01	6.95
Hauling	0.00	0.00	0.00	0.00	0.00	0.00	0.00	0.00	0.00	0.00	0.00	—	0.00	0.00	0.00	0.00	0.00	0.00

3.9. Paving (2024) - Unmitigated

Criteria Pollutants (lb/day for daily, ton/yr for annual) and GHGs (lb/day for daily, MT/yr for annual)

Location	TOG	ROG	NOx	CO	SO2	PM10E	PM10D	PM10T	PM2.5E	PM2.5D	PM2.5T	BCO2	NBCO2	CO2T	CH4	N2O	R	CO2e
Onsite	—	—	—	—	—	—	—	—	—	—	—	—	—	—	—	—	—	—
Daily, Summer (Max)	—	—	—	—	—	—	—	—	—	—	—	—	—	—	—	—	—	—
Off-Road Equipment	0.91	0.76	6.87	8.89	0.01	0.33	—	0.33	0.30	—	0.30	—	1,351	1,351	0.05	0.01	—	1,355
Paving	—	0.44	—	—	—	—	—	—	—	—	—	—	—	—	—	—	—	—
Onsite truck	0.00	0.00	0.00	0.00	0.00	0.00	0.00	0.00	0.00	0.00	0.00	—	0.00	0.00	0.00	0.00	0.00	0.00
Daily, Winter (Max)	—	—	—	—	—	—	—	—	—	—	—	—	—	—	—	—	—	—
Average Daily	—	—	—	—	—	—	—	—	—	—	—	—	—	—	—	—	—	—

Attachment 9

Off-Road Equipment	0.04	0.04	0.34	0.44	< 0.005	0.02	—	0.02	0.01	—	0.01	—	66.6	66.6	< 0.005	< 0.005	—	66.8
Paving	—	0.02	—	—	—	—	—	—	—	—	—	—	—	—	—	—	—	—
Onsite truck	0.00	0.00	0.00	0.00	0.00	0.00	0.00	0.00	0.00	0.00	0.00	—	0.00	0.00	0.00	0.00	0.00	0.00
Annual	—	—	—	—	—	—	—	—	—	—	—	—	—	—	—	—	—	—
Off-Road Equipment	0.01	0.01	0.06	0.08	< 0.005	< 0.005	—	< 0.005	< 0.005	—	< 0.005	—	11.0	11.0	< 0.005	< 0.005	—	11.1
Paving	—	< 0.005	—	—	—	—	—	—	—	—	—	—	—	—	—	—	—	—
Onsite truck	0.00	0.00	0.00	0.00	0.00	0.00	0.00	0.00	0.00	0.00	0.00	—	0.00	0.00	0.00	0.00	0.00	0.00
Offsite	—	—	—	—	—	—	—	—	—	—	—	—	—	—	—	—	—	—
Daily, Summer (Max)	—	—	—	—	—	—	—	—	—	—	—	—	—	—	—	—	—	—
Worker	0.09	0.08	0.06	0.70	0.00	0.00	0.01	0.01	0.00	0.00	0.00	—	124	124	0.01	0.01	0.55	127
Vendor	0.00	0.00	0.00	0.00	0.00	0.00	0.00	0.00	0.00	0.00	0.00	—	0.00	0.00	0.00	0.00	0.00	0.00
Hauling	0.00	0.00	0.00	0.00	0.00	0.00	0.00	0.00	0.00	0.00	0.00	—	0.00	0.00	0.00	0.00	0.00	0.00
Daily, Winter (Max)	—	—	—	—	—	—	—	—	—	—	—	—	—	—	—	—	—	—
Average Daily	—	—	—	—	—	—	—	—	—	—	—	—	—	—	—	—	—	—
Worker	< 0.005	< 0.005	< 0.005	0.03	0.00	0.00	< 0.005	< 0.005	0.00	0.00	0.00	—	5.91	5.91	< 0.005	< 0.005	0.01	6.01
Vendor	0.00	0.00	0.00	0.00	0.00	0.00	0.00	0.00	0.00	0.00	0.00	—	0.00	0.00	0.00	0.00	0.00	0.00
Hauling	0.00	0.00	0.00	0.00	0.00	0.00	0.00	0.00	0.00	0.00	0.00	—	0.00	0.00	0.00	0.00	0.00	0.00
Annual	—	—	—	—	—	—	—	—	—	—	—	—	—	—	—	—	—	—
Worker	< 0.005	< 0.005	< 0.005	0.01	0.00	0.00	< 0.005	< 0.005	0.00	0.00	0.00	—	0.98	0.98	< 0.005	< 0.005	< 0.005	1.00
Vendor	0.00	0.00	0.00	0.00	0.00	0.00	0.00	0.00	0.00	0.00	0.00	—	0.00	0.00	0.00	0.00	0.00	0.00
Hauling	0.00	0.00	0.00	0.00	0.00	0.00	0.00	0.00	0.00	0.00	0.00	—	0.00	0.00	0.00	0.00	0.00	0.00

3.10. Paving (2024) - Mitigated

Criteria Pollutants (lb/day for daily, ton/yr for annual) and GHGs (lb/day for daily, MT/yr for annual)

Location	TOG	ROG	NOx	CO	SO2	PM10E	PM10D	PM10T	PM2.5E	PM2.5D	PM2.5T	BCO2	NBCO2	CO2T	CH4	N2O	R	CO2e
Onsite	—	—	—	—	—	—	—	—	—	—	—	—	—	—	—	—	—	—
Daily, Summer (Max)	—	—	—	—	—	—	—	—	—	—	—	—	—	—	—	—	—	—
Off-Road Equipment	0.91	0.76	6.87	8.89	0.01	0.33	—	0.33	0.30	—	0.30	—	1,351	1,351	0.05	0.01	—	1,355
Paving	—	0.44	—	—	—	—	—	—	—	—	—	—	—	—	—	—	—	—
Onsite truck	0.00	0.00	0.00	0.00	0.00	0.00	0.00	0.00	0.00	0.00	0.00	—	0.00	0.00	0.00	0.00	0.00	0.00
Daily, Winter (Max)	—	—	—	—	—	—	—	—	—	—	—	—	—	—	—	—	—	—
Average Daily	—	—	—	—	—	—	—	—	—	—	—	—	—	—	—	—	—	—
Off-Road Equipment	0.04	0.04	0.34	0.44	< 0.005	0.02	—	0.02	0.01	—	0.01	—	66.6	66.6	< 0.005	< 0.005	—	66.8
Paving	—	0.02	—	—	—	—	—	—	—	—	—	—	—	—	—	—	—	—
Onsite truck	0.00	0.00	0.00	0.00	0.00	0.00	0.00	0.00	0.00	0.00	0.00	—	0.00	0.00	0.00	0.00	0.00	0.00
Annual	—	—	—	—	—	—	—	—	—	—	—	—	—	—	—	—	—	—
Off-Road Equipment	0.01	0.01	0.06	0.08	< 0.005	< 0.005	—	< 0.005	< 0.005	—	< 0.005	—	11.0	11.0	< 0.005	< 0.005	—	11.1
Paving	—	< 0.005	—	—	—	—	—	—	—	—	—	—	—	—	—	—	—	—
Onsite truck	0.00	0.00	0.00	0.00	0.00	0.00	0.00	0.00	0.00	0.00	0.00	—	0.00	0.00	0.00	0.00	0.00	0.00
Offsite	—	—	—	—	—	—	—	—	—	—	—	—	—	—	—	—	—	—
Daily, Summer (Max)	—	—	—	—	—	—	—	—	—	—	—	—	—	—	—	—	—	—

Attachment 9

Worker	0.09	0.08	0.06	0.70	0.00	0.00	0.01	0.01	0.00	0.00	0.00	—	124	124	0.01	0.01	0.55	127
Vendor	0.00	0.00	0.00	0.00	0.00	0.00	0.00	0.00	0.00	0.00	0.00	—	0.00	0.00	0.00	0.00	0.00	0.00
Hauling	0.00	0.00	0.00	0.00	0.00	0.00	0.00	0.00	0.00	0.00	0.00	—	0.00	0.00	0.00	0.00	0.00	0.00
Daily, Winter (Max)	—	—	—	—	—	—	—	—	—	—	—	—	—	—	—	—	—	—
Average Daily	—	—	—	—	—	—	—	—	—	—	—	—	—	—	—	—	—	—
Worker	< 0.005	< 0.005	< 0.005	0.03	0.00	0.00	< 0.005	< 0.005	0.00	0.00	0.00	—	5.91	5.91	< 0.005	< 0.005	0.01	6.01
Vendor	0.00	0.00	0.00	0.00	0.00	0.00	0.00	0.00	0.00	0.00	0.00	—	0.00	0.00	0.00	0.00	0.00	0.00
Hauling	0.00	0.00	0.00	0.00	0.00	0.00	0.00	0.00	0.00	0.00	0.00	—	0.00	0.00	0.00	0.00	0.00	0.00
Annual	—	—	—	—	—	—	—	—	—	—	—	—	—	—	—	—	—	—
Worker	< 0.005	< 0.005	< 0.005	0.01	0.00	0.00	< 0.005	< 0.005	0.00	0.00	0.00	—	0.98	0.98	< 0.005	< 0.005	< 0.005	1.00
Vendor	0.00	0.00	0.00	0.00	0.00	0.00	0.00	0.00	0.00	0.00	0.00	—	0.00	0.00	0.00	0.00	0.00	0.00
Hauling	0.00	0.00	0.00	0.00	0.00	0.00	0.00	0.00	0.00	0.00	0.00	—	0.00	0.00	0.00	0.00	0.00	0.00

3.11. Architectural Coating (2024) - Unmitigated

Criteria Pollutants (lb/day for daily, ton/yr for annual) and GHGs (lb/day for daily, MT/yr for annual)

Location	TOG	ROG	NOx	CO	SO2	PM10E	PM10D	PM10T	PM2.5E	PM2.5D	PM2.5T	BCO2	NBCO2	CO2T	CH4	N2O	R	CO2e
Onsite	—	—	—	—	—	—	—	—	—	—	—	—	—	—	—	—	—	—
Daily, Summer (Max)	—	—	—	—	—	—	—	—	—	—	—	—	—	—	—	—	—	—
Off-Road Equipment	0.17	0.14	0.91	1.15	< 0.005	0.03	—	0.03	0.03	—	0.03	—	134	134	0.01	< 0.005	—	134
Architectural Coatings	—	40.3	—	—	—	—	—	—	—	—	—	—	—	—	—	—	—	—
Onsite truck	0.00	0.00	0.00	0.00	0.00	0.00	0.00	0.00	0.00	0.00	0.00	—	0.00	0.00	0.00	0.00	0.00	0.00

Attachment 9

Daily, Winter (Max)	—	—	—	—	—	—	—	—	—	—	—	—	—	—	—	—	—	—
Average Daily	—	—	—	—	—	—	—	—	—	—	—	—	—	—	—	—	—	—
Off-Road Equipment	0.01	0.01	0.04	0.06	< 0.005	< 0.005	—	< 0.005	< 0.005	—	< 0.005	—	6.58	6.58	< 0.005	< 0.005	—	6.61
Architect ural Coatings	—	1.99	—	—	—	—	—	—	—	—	—	—	—	—	—	—	—	—
Onsite truck	0.00	0.00	0.00	0.00	0.00	0.00	0.00	0.00	0.00	0.00	0.00	—	0.00	0.00	0.00	0.00	0.00	0.00
Annual	—	—	—	—	—	—	—	—	—	—	—	—	—	—	—	—	—	—
Off-Road Equipment	< 0.005	< 0.005	0.01	0.01	< 0.005	< 0.005	—	< 0.005	< 0.005	—	< 0.005	—	1.09	1.09	< 0.005	< 0.005	—	1.09
Architect ural Coatings	—	0.36	—	—	—	—	—	—	—	—	—	—	—	—	—	—	—	—
Onsite truck	0.00	0.00	0.00	0.00	0.00	0.00	0.00	0.00	0.00	0.00	0.00	—	0.00	0.00	0.00	0.00	0.00	0.00
Offsite	—	—	—	—	—	—	—	—	—	—	—	—	—	—	—	—	—	—
Daily, Summer (Max)	—	—	—	—	—	—	—	—	—	—	—	—	—	—	—	—	—	—
Worker	0.01	0.01	0.01	0.06	0.00	0.00	< 0.005	< 0.005	0.00	0.00	0.00	—	11.3	11.3	< 0.005	< 0.005	0.05	11.5
Vendor	0.00	0.00	0.00	0.00	0.00	0.00	0.00	0.00	0.00	0.00	0.00	—	0.00	0.00	0.00	0.00	0.00	0.00
Hauling	0.00	0.00	0.00	0.00	0.00	0.00	0.00	0.00	0.00	0.00	0.00	—	0.00	0.00	0.00	0.00	0.00	0.00
Daily, Winter (Max)	—	—	—	—	—	—	—	—	—	—	—	—	—	—	—	—	—	—
Average Daily	—	—	—	—	—	—	—	—	—	—	—	—	—	—	—	—	—	—
Worker	< 0.005	< 0.005	< 0.005	< 0.005	0.00	0.00	< 0.005	< 0.005	0.00	0.00	0.00	—	0.54	0.54	< 0.005	< 0.005	< 0.005	0.55

Attachment 9

Vendor	0.00	0.00	0.00	0.00	0.00	0.00	0.00	0.00	0.00	0.00	0.00	0.00	—	0.00	0.00	0.00	0.00	0.00	0.00
Hauling	0.00	0.00	0.00	0.00	0.00	0.00	0.00	0.00	0.00	0.00	0.00	0.00	—	0.00	0.00	0.00	0.00	0.00	0.00
Annual	—	—	—	—	—	—	—	—	—	—	—	—	—	—	—	—	—	—	—
Worker	< 0.005	< 0.005	< 0.005	< 0.005	0.00	0.00	< 0.005	< 0.005	0.00	0.00	0.00	0.00	—	0.09	0.09	< 0.005	< 0.005	< 0.005	0.09
Vendor	0.00	0.00	0.00	0.00	0.00	0.00	0.00	0.00	0.00	0.00	0.00	0.00	—	0.00	0.00	0.00	0.00	0.00	0.00
Hauling	0.00	0.00	0.00	0.00	0.00	0.00	0.00	0.00	0.00	0.00	0.00	0.00	—	0.00	0.00	0.00	0.00	0.00	0.00

3.12. Architectural Coating (2024) - Mitigated

Criteria Pollutants (lb/day for daily, ton/yr for annual) and GHGs (lb/day for daily, MT/yr for annual)

Location	TOG	ROG	NOx	CO	SO2	PM10E	PM10D	PM10T	PM2.5E	PM2.5D	PM2.5T	BCO2	NBCO2	CO2T	CH4	N2O	R	CO2e
Onsite	—	—	—	—	—	—	—	—	—	—	—	—	—	—	—	—	—	—
Daily, Summer (Max)	—	—	—	—	—	—	—	—	—	—	—	—	—	—	—	—	—	—
Off-Road Equipment	0.17	0.14	0.91	1.15	< 0.005	0.03	—	0.03	0.03	—	0.03	—	134	134	0.01	< 0.005	—	134
Architect ural Coatings	—	40.3	—	—	—	—	—	—	—	—	—	—	—	—	—	—	—	—
Onsite truck	0.00	0.00	0.00	0.00	0.00	0.00	0.00	0.00	0.00	0.00	0.00	—	0.00	0.00	0.00	0.00	0.00	0.00
Daily, Winter (Max)	—	—	—	—	—	—	—	—	—	—	—	—	—	—	—	—	—	—
Average Daily	—	—	—	—	—	—	—	—	—	—	—	—	—	—	—	—	—	—
Off-Road Equipment	0.01	0.01	0.04	0.06	< 0.005	< 0.005	—	< 0.005	< 0.005	—	< 0.005	—	6.58	6.58	< 0.005	< 0.005	—	6.61
Architect ural Coatings	—	1.99	—	—	—	—	—	—	—	—	—	—	—	—	—	—	—	—

Attachment 9

Onsite truck	0.00	0.00	0.00	0.00	0.00	0.00	0.00	0.00	0.00	0.00	0.00	—	0.00	0.00	0.00	0.00	0.00	0.00
Annual	—	—	—	—	—	—	—	—	—	—	—	—	—	—	—	—	—	—
Off-Road Equipment	< 0.005	< 0.005	0.01	0.01	< 0.005	< 0.005	—	< 0.005	< 0.005	—	< 0.005	—	1.09	1.09	< 0.005	< 0.005	—	1.09
Architectural Coatings	—	0.36	—	—	—	—	—	—	—	—	—	—	—	—	—	—	—	—
Onsite truck	0.00	0.00	0.00	0.00	0.00	0.00	0.00	0.00	0.00	0.00	0.00	—	0.00	0.00	0.00	0.00	0.00	0.00
Offsite	—	—	—	—	—	—	—	—	—	—	—	—	—	—	—	—	—	—
Daily, Summer (Max)	—	—	—	—	—	—	—	—	—	—	—	—	—	—	—	—	—	—
Worker	0.01	0.01	0.01	0.06	0.00	0.00	< 0.005	< 0.005	0.00	0.00	0.00	—	11.3	11.3	< 0.005	< 0.005	0.05	11.5
Vendor	0.00	0.00	0.00	0.00	0.00	0.00	0.00	0.00	0.00	0.00	0.00	—	0.00	0.00	0.00	0.00	0.00	0.00
Hauling	0.00	0.00	0.00	0.00	0.00	0.00	0.00	0.00	0.00	0.00	0.00	—	0.00	0.00	0.00	0.00	0.00	0.00
Daily, Winter (Max)	—	—	—	—	—	—	—	—	—	—	—	—	—	—	—	—	—	—
Average Daily	—	—	—	—	—	—	—	—	—	—	—	—	—	—	—	—	—	—
Worker	< 0.005	< 0.005	< 0.005	< 0.005	0.00	0.00	< 0.005	< 0.005	0.00	0.00	0.00	—	0.54	0.54	< 0.005	< 0.005	< 0.005	0.55
Vendor	0.00	0.00	0.00	0.00	0.00	0.00	0.00	0.00	0.00	0.00	0.00	—	0.00	0.00	0.00	0.00	0.00	0.00
Hauling	0.00	0.00	0.00	0.00	0.00	0.00	0.00	0.00	0.00	0.00	0.00	—	0.00	0.00	0.00	0.00	0.00	0.00
Annual	—	—	—	—	—	—	—	—	—	—	—	—	—	—	—	—	—	—
Worker	< 0.005	< 0.005	< 0.005	< 0.005	0.00	0.00	< 0.005	< 0.005	0.00	0.00	0.00	—	0.09	0.09	< 0.005	< 0.005	< 0.005	0.09
Vendor	0.00	0.00	0.00	0.00	0.00	0.00	0.00	0.00	0.00	0.00	0.00	—	0.00	0.00	0.00	0.00	0.00	0.00
Hauling	0.00	0.00	0.00	0.00	0.00	0.00	0.00	0.00	0.00	0.00	0.00	—	0.00	0.00	0.00	0.00	0.00	0.00

4. Operations Emissions Details

4.1. Mobile Emissions by Land Use

4.1.1. Unmitigated

Mobile source emissions results are presented in Sections 2.6. No further detailed breakdown of emissions is available.

4.1.2. Mitigated

Mobile source emissions results are presented in Sections 2.5. No further detailed breakdown of emissions is available.

4.2. Energy

4.2.1. Electricity Emissions By Land Use - Unmitigated

Criteria Pollutants (lb/day for daily, ton/yr for annual) and GHGs (lb/day for daily, MT/yr for annual)

Land Use	TOG	ROG	NOx	CO	SO2	PM10E	PM10D	PM10T	PM2.5E	PM2.5D	PM2.5T	BCO2	NBCO2	CO2T	CH4	N2O	R	CO2e
Daily, Summer (Max)	—	—	—	—	—	—	—	—	—	—	—	—	—	—	—	—	—	—
General Light Industry	—	—	—	—	—	—	—	—	—	—	—	—	62.0	62.0	0.01	< 0.005	—	62.6
Automobile Care Center	—	—	—	—	—	—	—	—	—	—	—	—	78.9	78.9	0.01	< 0.005	—	79.7
Parking Lot	—	—	—	—	—	—	—	—	—	—	—	—	64.0	64.0	0.01	< 0.005	—	64.6
undefined	—	—	—	—	—	—	—	—	—	—	—	—	216	216	0.03	< 0.005	—	218
Total	—	—	—	—	—	—	—	—	—	—	—	—	421	421	0.07	0.01	—	425
Daily, Winter (Max)	—	—	—	—	—	—	—	—	—	—	—	—	—	—	—	—	—	—

Attachment 9

General Light Industry	—	—	—	—	—	—	—	—	—	—	—	—	62.0	62.0	0.01	< 0.005	—	62.6
Automobile Care Center	—	—	—	—	—	—	—	—	—	—	—	—	78.9	78.9	0.01	< 0.005	—	79.7
Parking Lot	—	—	—	—	—	—	—	—	—	—	—	—	64.0	64.0	0.01	< 0.005	—	64.6
undefined	—	—	—	—	—	—	—	—	—	—	—	—	216	216	0.03	< 0.005	—	218
Total	—	—	—	—	—	—	—	—	—	—	—	—	421	421	0.07	0.01	—	425
Annual	—	—	—	—	—	—	—	—	—	—	—	—	—	—	—	—	—	—
General Light Industry	—	—	—	—	—	—	—	—	—	—	—	—	10.3	10.3	< 0.005	< 0.005	—	10.4
Automobile Care Center	—	—	—	—	—	—	—	—	—	—	—	—	13.1	13.1	< 0.005	< 0.005	—	13.2
Parking Lot	—	—	—	—	—	—	—	—	—	—	—	—	10.6	10.6	< 0.005	< 0.005	—	10.7
undefined	—	—	—	—	—	—	—	—	—	—	—	—	25.5	25.5	< 0.005	< 0.005	—	25.7
Total	—	—	—	—	—	—	—	—	—	—	—	—	59.4	59.4	0.01	< 0.005	—	60.0

4.2.2. Electricity Emissions By Land Use - Mitigated

Criteria Pollutants (lb/day for daily, ton/yr for annual) and GHGs (lb/day for daily, MT/yr for annual)

Land Use	TOG	ROG	NOx	CO	SO2	PM10E	PM10D	PM10T	PM2.5E	PM2.5D	PM2.5T	BCO2	NBCO2	CO2T	CH4	N2O	R	CO2e
Daily, Summer (Max)	—	—	—	—	—	—	—	—	—	—	—	—	—	—	—	—	—	—

Attachment 9

General Light Industry	—	—	—	—	—	—	—	—	—	—	—	—	62.0	62.0	0.01	< 0.005	—	62.6
Automobile Care Center	—	—	—	—	—	—	—	—	—	—	—	—	78.9	78.9	0.01	< 0.005	—	79.7
Parking Lot	—	—	—	—	—	—	—	—	—	—	—	—	64.0	64.0	0.01	< 0.005	—	64.6
undefined	—	—	—	—	—	—	—	—	—	—	—	—	216	216	0.03	< 0.005	—	218
Total	—	—	—	—	—	—	—	—	—	—	—	—	421	421	0.07	0.01	—	425
Daily, Winter (Max)	—	—	—	—	—	—	—	—	—	—	—	—	—	—	—	—	—	—
General Light Industry	—	—	—	—	—	—	—	—	—	—	—	—	62.0	62.0	0.01	< 0.005	—	62.6
Automobile Care Center	—	—	—	—	—	—	—	—	—	—	—	—	78.9	78.9	0.01	< 0.005	—	79.7
Parking Lot	—	—	—	—	—	—	—	—	—	—	—	—	64.0	64.0	0.01	< 0.005	—	64.6
undefined	—	—	—	—	—	—	—	—	—	—	—	—	216	216	0.03	< 0.005	—	218
Total	—	—	—	—	—	—	—	—	—	—	—	—	421	421	0.07	0.01	—	425
Annual	—	—	—	—	—	—	—	—	—	—	—	—	—	—	—	—	—	—
General Light Industry	—	—	—	—	—	—	—	—	—	—	—	—	10.3	10.3	< 0.005	< 0.005	—	10.4
Automobile Care Center	—	—	—	—	—	—	—	—	—	—	—	—	13.1	13.1	< 0.005	< 0.005	—	13.2

Attachment 9

Parking Lot	—	—	—	—	—	—	—	—	—	—	—	—	10.6	10.6	< 0.005	< 0.005	—	10.7
undefined	—	—	—	—	—	—	—	—	—	—	—	—	25.5	25.5	< 0.005	< 0.005	—	25.7
Total	—	—	—	—	—	—	—	—	—	—	—	—	59.4	59.4	0.01	< 0.005	—	60.0

4.2.3. Natural Gas Emissions By Land Use - Unmitigated

Criteria Pollutants (lb/day for daily, ton/yr for annual) and GHGs (lb/day for daily, MT/yr for annual)

Land Use	TOG	ROG	NOx	CO	SO2	PM10E	PM10D	PM10T	PM2.5E	PM2.5D	PM2.5T	BCO2	NBCO2	CO2T	CH4	N2O	R	CO2e
Daily, Summer (Max)	—	—	—	—	—	—	—	—	—	—	—	—	—	—	—	—	—	—
General Light Industry	0.01	0.01	0.12	0.10	< 0.005	0.01	—	0.01	0.01	—	0.01	—	149	149	0.01	< 0.005	—	149
Automobile Care Center	0.02	0.01	0.16	0.13	< 0.005	0.01	—	0.01	0.01	—	0.01	—	189	189	0.02	< 0.005	—	190
Parking Lot	0.00	0.00	0.00	0.00	0.00	0.00	—	0.00	0.00	—	0.00	—	0.00	0.00	0.00	0.00	—	0.00
Total	0.03	0.02	0.28	0.24	< 0.005	0.02	—	0.02	0.02	—	0.02	—	338	338	0.03	< 0.005	—	339
Daily, Winter (Max)	—	—	—	—	—	—	—	—	—	—	—	—	—	—	—	—	—	—
General Light Industry	0.01	0.01	0.12	0.10	< 0.005	0.01	—	0.01	0.01	—	0.01	—	149	149	0.01	< 0.005	—	149
Automobile Care Center	0.02	0.01	0.16	0.13	< 0.005	0.01	—	0.01	0.01	—	0.01	—	189	189	0.02	< 0.005	—	190

Attachment 9

Parking Lot	0.00	0.00	0.00	0.00	0.00	0.00	—	0.00	0.00	—	0.00	—	0.00	0.00	0.00	0.00	—	0.00
Total	0.03	0.02	0.28	0.24	< 0.005	0.02	—	0.02	0.02	—	0.02	—	338	338	0.03	< 0.005	—	339
Annual	—	—	—	—	—	—	—	—	—	—	—	—	—	—	—	—	—	—
General Light Industry	< 0.005	< 0.005	0.02	0.02	< 0.005	< 0.005	—	< 0.005	< 0.005	—	< 0.005	—	24.6	24.6	< 0.005	< 0.005	—	24.7
Automobile Care Center	< 0.005	< 0.005	0.03	0.02	< 0.005	< 0.005	—	< 0.005	< 0.005	—	< 0.005	—	31.3	31.3	< 0.005	< 0.005	—	31.4
Parking Lot	0.00	0.00	0.00	0.00	0.00	0.00	—	0.00	0.00	—	0.00	—	0.00	0.00	0.00	0.00	—	0.00
Total	0.01	< 0.005	0.05	0.04	< 0.005	< 0.005	—	< 0.005	< 0.005	—	< 0.005	—	56.0	56.0	< 0.005	< 0.005	—	56.1

4.2.4. Natural Gas Emissions By Land Use - Mitigated

Criteria Pollutants (lb/day for daily, ton/yr for annual) and GHGs (lb/day for daily, MT/yr for annual)

Land Use	TOG	ROG	NOx	CO	SO2	PM10E	PM10D	PM10T	PM2.5E	PM2.5D	PM2.5T	BCO2	NBCO2	CO2T	CH4	N2O	R	CO2e
Daily, Summer (Max)	—	—	—	—	—	—	—	—	—	—	—	—	—	—	—	—	—	—
General Light Industry	0.01	0.01	0.12	0.10	< 0.005	0.01	—	0.01	0.01	—	0.01	—	149	149	0.01	< 0.005	—	149
Automobile Care Center	0.02	0.01	0.16	0.13	< 0.005	0.01	—	0.01	0.01	—	0.01	—	189	189	0.02	< 0.005	—	190
Parking Lot	0.00	0.00	0.00	0.00	0.00	0.00	—	0.00	0.00	—	0.00	—	0.00	0.00	0.00	0.00	—	0.00
Total	0.03	0.02	0.28	0.24	< 0.005	0.02	—	0.02	0.02	—	0.02	—	338	338	0.03	< 0.005	—	339

Attachment 9

Daily, Winter (Max)	—	—	—	—	—	—	—	—	—	—	—	—	—	—	—	—	—	—
General Light Industry	0.01	0.01	0.12	0.10	< 0.005	0.01	—	0.01	0.01	—	0.01	—	149	149	0.01	< 0.005	—	149
Automobile Care Center	0.02	0.01	0.16	0.13	< 0.005	0.01	—	0.01	0.01	—	0.01	—	189	189	0.02	< 0.005	—	190
Parking Lot	0.00	0.00	0.00	0.00	0.00	0.00	—	0.00	0.00	—	0.00	—	0.00	0.00	0.00	0.00	—	0.00
Total	0.03	0.02	0.28	0.24	< 0.005	0.02	—	0.02	0.02	—	0.02	—	338	338	0.03	< 0.005	—	339
Annual	—	—	—	—	—	—	—	—	—	—	—	—	—	—	—	—	—	—
General Light Industry	< 0.005	< 0.005	0.02	0.02	< 0.005	< 0.005	—	< 0.005	< 0.005	—	< 0.005	—	24.6	24.6	< 0.005	< 0.005	—	24.7
Automobile Care Center	< 0.005	< 0.005	0.03	0.02	< 0.005	< 0.005	—	< 0.005	< 0.005	—	< 0.005	—	31.3	31.3	< 0.005	< 0.005	—	31.4
Parking Lot	0.00	0.00	0.00	0.00	0.00	0.00	—	0.00	0.00	—	0.00	—	0.00	0.00	0.00	0.00	—	0.00
Total	0.01	< 0.005	0.05	0.04	< 0.005	< 0.005	—	< 0.005	< 0.005	—	< 0.005	—	56.0	56.0	< 0.005	< 0.005	—	56.1

4.3. Area Emissions by Source

4.3.2. Unmitigated

Criteria Pollutants (lb/day for daily, ton/yr for annual) and GHGs (lb/day for daily, MT/yr for annual)

Source	TOG	ROG	NOx	CO	SO2	PM10E	PM10D	PM10T	PM2.5E	PM2.5D	PM2.5T	BCO2	NBCO2	CO2T	CH4	N2O	R	CO2e
Daily, Summer (Max)	—	—	—	—	—	—	—	—	—	—	—	—	—	—	—	—	—	—

Attachment 9

Architectural Coatings	—	40.5	—	—	—	—	—	—	—	—	—	—	—	—	—	—	—	—
Consumer Products	—	0.55	—	—	—	—	—	—	—	—	—	—	—	—	—	—	—	—
Landscape Equipment	0.19	0.18	0.01	1.09	< 0.005	< 0.005	—	< 0.005	< 0.005	—	< 0.005	—	4.47	4.47	< 0.005	< 0.005	—	4.49
Total	0.19	41.2	0.01	1.09	< 0.005	< 0.005	—	< 0.005	< 0.005	—	< 0.005	—	4.47	4.47	< 0.005	< 0.005	—	4.49
Daily, Winter (Max)	—	—	—	—	—	—	—	—	—	—	—	—	—	—	—	—	—	—
Consumer Products	—	0.55	—	—	—	—	—	—	—	—	—	—	—	—	—	—	—	—
Architectural Coatings	—	0.20	—	—	—	—	—	—	—	—	—	—	—	—	—	—	—	—
Total	—	0.74	—	—	—	—	—	—	—	—	—	—	—	—	—	—	—	—
Annual	—	—	—	—	—	—	—	—	—	—	—	—	—	—	—	—	—	—
Architectural Coatings	—	0.40	—	—	—	—	—	—	—	—	—	—	—	—	—	—	—	—
Consumer Products	—	0.10	—	—	—	—	—	—	—	—	—	—	—	—	—	—	—	—
Landscape Equipment	0.03	0.03	< 0.005	0.18	< 0.005	< 0.005	—	< 0.005	< 0.005	—	< 0.005	—	0.67	0.67	< 0.005	< 0.005	—	0.67
Total	0.03	0.53	< 0.005	0.18	< 0.005	< 0.005	—	< 0.005	< 0.005	—	< 0.005	—	0.67	0.67	< 0.005	< 0.005	—	0.67

4.3.1. Mitigated

Attachment 9

Criteria Pollutants (lb/day for daily, ton/yr for annual) and GHGs (lb/day for daily, MT/yr for annual)

Source	TOG	ROG	NOx	CO	SO2	PM10E	PM10D	PM10T	PM2.5E	PM2.5D	PM2.5T	BCO2	NBCO2	CO2T	CH4	N2O	R	CO2e
Daily, Summer (Max)	—	—	—	—	—	—	—	—	—	—	—	—	—	—	—	—	—	—
Architectural Coatings	—	40.5	—	—	—	—	—	—	—	—	—	—	—	—	—	—	—	—
Consumer Products	—	0.55	—	—	—	—	—	—	—	—	—	—	—	—	—	—	—	—
Landscape Equipment	0.19	0.18	0.01	1.09	< 0.005	< 0.005	—	< 0.005	< 0.005	—	< 0.005	—	4.47	4.47	< 0.005	< 0.005	—	4.49
Total	0.19	41.2	0.01	1.09	< 0.005	< 0.005	—	< 0.005	< 0.005	—	< 0.005	—	4.47	4.47	< 0.005	< 0.005	—	4.49
Daily, Winter (Max)	—	—	—	—	—	—	—	—	—	—	—	—	—	—	—	—	—	—
Consumer Products	—	0.55	—	—	—	—	—	—	—	—	—	—	—	—	—	—	—	—
Architectural Coatings	—	0.20	—	—	—	—	—	—	—	—	—	—	—	—	—	—	—	—
Total	—	0.74	—	—	—	—	—	—	—	—	—	—	—	—	—	—	—	—
Annual	—	—	—	—	—	—	—	—	—	—	—	—	—	—	—	—	—	—
Architectural Coatings	—	0.40	—	—	—	—	—	—	—	—	—	—	—	—	—	—	—	—
Consumer Products	—	0.10	—	—	—	—	—	—	—	—	—	—	—	—	—	—	—	—

Attachment 9

Landscape Equipment	0.03	0.03	< 0.005	0.18	< 0.005	< 0.005	—	< 0.005	< 0.005	—	< 0.005	—	0.67	0.67	< 0.005	< 0.005	—	0.67
Total	0.03	0.53	< 0.005	0.18	< 0.005	< 0.005	—	< 0.005	< 0.005	—	< 0.005	—	0.67	0.67	< 0.005	< 0.005	—	0.67

4.4. Water Emissions by Land Use

4.4.2. Unmitigated

Criteria Pollutants (lb/day for daily, ton/yr for annual) and GHGs (lb/day for daily, MT/yr for annual)

Land Use	TOG	ROG	NOx	CO	SO2	PM10E	PM10D	PM10T	PM2.5E	PM2.5D	PM2.5T	BCO2	NBCO2	CO2T	CH4	N2O	R	CO2e
Daily, Summer (Max)	—	—	—	—	—	—	—	—	—	—	—	—	—	—	—	—	—	—
General Light Industry	—	—	—	—	—	—	—	—	—	—	—	4.87	8.88	13.8	0.50	0.01	—	29.9
Automobile Care Center	—	—	—	—	—	—	—	—	—	—	—	2.52	3.98	6.51	0.26	0.01	—	14.8
Parking Lot	—	—	—	—	—	—	—	—	—	—	—	0.00	< 0.005	< 0.005	< 0.005	< 0.005	—	< 0.005
Total	—	—	—	—	—	—	—	—	—	—	—	7.40	12.9	20.3	0.76	0.02	—	44.7
Daily, Winter (Max)	—	—	—	—	—	—	—	—	—	—	—	—	—	—	—	—	—	—
General Light Industry	—	—	—	—	—	—	—	—	—	—	—	4.87	8.88	13.8	0.50	0.01	—	29.9
Automobile Care Center	—	—	—	—	—	—	—	—	—	—	—	2.52	3.98	6.51	0.26	0.01	—	14.8

Attachment 9

Parking Lot	—	—	—	—	—	—	—	—	—	—	—	0.00	< 0.005	< 0.005	< 0.005	< 0.005	—	< 0.005
Total	—	—	—	—	—	—	—	—	—	—	—	7.40	12.9	20.3	0.76	0.02	—	44.7
Annual	—	—	—	—	—	—	—	—	—	—	—	—	—	—	—	—	—	—
General Light Industry	—	—	—	—	—	—	—	—	—	—	—	0.81	1.47	2.28	0.08	< 0.005	—	4.95
Automobile Care Center	—	—	—	—	—	—	—	—	—	—	—	0.42	0.66	1.08	0.04	< 0.005	—	2.46
Parking Lot	—	—	—	—	—	—	—	—	—	—	—	0.00	< 0.005	< 0.005	< 0.005	< 0.005	—	< 0.005
Total	—	—	—	—	—	—	—	—	—	—	—	1.22	2.13	3.35	0.13	< 0.005	—	7.40

4.4.1. Mitigated

Criteria Pollutants (lb/day for daily, ton/yr for annual) and GHGs (lb/day for daily, MT/yr for annual)

Land Use	TOG	ROG	NOx	CO	SO2	PM10E	PM10D	PM10T	PM2.5E	PM2.5D	PM2.5T	BCO2	NBCO2	CO2T	CH4	N2O	R	CO2e
Daily, Summer (Max)	—	—	—	—	—	—	—	—	—	—	—	—	—	—	—	—	—	—
General Light Industry	—	—	—	—	—	—	—	—	—	—	—	4.87	8.22	13.1	0.50	0.01	—	29.2
Automobile Care Center	—	—	—	—	—	—	—	—	—	—	—	2.52	3.98	6.51	0.26	0.01	—	14.8
Parking Lot	—	—	—	—	—	—	—	—	—	—	—	0.00	< 0.005	< 0.005	< 0.005	< 0.005	—	< 0.005
Total	—	—	—	—	—	—	—	—	—	—	—	7.40	12.2	19.6	0.76	0.02	—	44.1

Attachment 9

Daily, Winter (Max)	—	—	—	—	—	—	—	—	—	—	—	—	—	—	—	—	—	—
General Light Industry	—	—	—	—	—	—	—	—	—	—	—	4.87	8.22	13.1	0.50	0.01	—	29.2
Automobile Care Center	—	—	—	—	—	—	—	—	—	—	—	2.52	3.98	6.51	0.26	0.01	—	14.8
Parking Lot	—	—	—	—	—	—	—	—	—	—	—	0.00	< 0.005	< 0.005	< 0.005	< 0.005	—	< 0.005
Total	—	—	—	—	—	—	—	—	—	—	—	7.40	12.2	19.6	0.76	0.02	—	44.1
Annual	—	—	—	—	—	—	—	—	—	—	—	—	—	—	—	—	—	—
General Light Industry	—	—	—	—	—	—	—	—	—	—	—	0.81	1.36	2.17	0.08	< 0.005	—	4.84
Automobile Care Center	—	—	—	—	—	—	—	—	—	—	—	0.42	0.66	1.08	0.04	< 0.005	—	2.46
Parking Lot	—	—	—	—	—	—	—	—	—	—	—	0.00	< 0.005	< 0.005	< 0.005	< 0.005	—	< 0.005
Total	—	—	—	—	—	—	—	—	—	—	—	1.22	2.02	3.25	0.13	< 0.005	—	7.30

4.5. Waste Emissions by Land Use

4.5.2. Unmitigated

Criteria Pollutants (lb/day for daily, ton/yr for annual) and GHGs (lb/day for daily, MT/yr for annual)

Land Use	TOG	ROG	NOx	CO	SO2	PM10E	PM10D	PM10T	PM2.5E	PM2.5D	PM2.5T	BCO2	NBCO2	CO2T	CH4	N2O	R	CO2e
Daily, Summer (Max)	—	—	—	—	—	—	—	—	—	—	—	—	—	—	—	—	—	—

Attachment 9

General Light Industry	—	—	—	—	—	—	—	—	—	—	—	7.35	0.00	7.35	0.73	0.00	—	25.7
Automobile Care Center	—	—	—	—	—	—	—	—	—	—	—	28.8	0.00	28.8	2.88	0.00	—	101
Parking Lot	—	—	—	—	—	—	—	—	—	—	—	0.00	0.00	0.00	0.00	0.00	—	0.00
Total	—	—	—	—	—	—	—	—	—	—	—	36.2	0.00	36.2	3.62	0.00	—	127
Daily, Winter (Max)	—	—	—	—	—	—	—	—	—	—	—	—	—	—	—	—	—	—
General Light Industry	—	—	—	—	—	—	—	—	—	—	—	7.35	0.00	7.35	0.73	0.00	—	25.7
Automobile Care Center	—	—	—	—	—	—	—	—	—	—	—	28.8	0.00	28.8	2.88	0.00	—	101
Parking Lot	—	—	—	—	—	—	—	—	—	—	—	0.00	0.00	0.00	0.00	0.00	—	0.00
Total	—	—	—	—	—	—	—	—	—	—	—	36.2	0.00	36.2	3.62	0.00	—	127
Annual	—	—	—	—	—	—	—	—	—	—	—	—	—	—	—	—	—	—
General Light Industry	—	—	—	—	—	—	—	—	—	—	—	1.22	0.00	1.22	0.12	0.00	—	4.26
Automobile Care Center	—	—	—	—	—	—	—	—	—	—	—	4.77	0.00	4.77	0.48	0.00	—	16.7
Parking Lot	—	—	—	—	—	—	—	—	—	—	—	0.00	0.00	0.00	0.00	0.00	—	0.00
Total	—	—	—	—	—	—	—	—	—	—	—	5.99	0.00	5.99	0.60	0.00	—	21.0

Attachment 9

4.5.1. Mitigated

Criteria Pollutants (lb/day for daily, ton/yr for annual) and GHGs (lb/day for daily, MT/yr for annual)

Land Use	TOG	ROG	NOx	CO	SO2	PM10E	PM10D	PM10T	PM2.5E	PM2.5D	PM2.5T	BCO2	NBCO2	CO2T	CH4	N2O	R	CO2e
Daily, Summer (Max)	—	—	—	—	—	—	—	—	—	—	—	—	—	—	—	—	—	—
General Light Industry	—	—	—	—	—	—	—	—	—	—	—	7.35	0.00	7.35	0.73	0.00	—	25.7
Automobile Care Center	—	—	—	—	—	—	—	—	—	—	—	28.8	0.00	28.8	2.88	0.00	—	101
Parking Lot	—	—	—	—	—	—	—	—	—	—	—	0.00	0.00	0.00	0.00	0.00	—	0.00
Total	—	—	—	—	—	—	—	—	—	—	—	36.2	0.00	36.2	3.62	0.00	—	127
Daily, Winter (Max)	—	—	—	—	—	—	—	—	—	—	—	—	—	—	—	—	—	—
General Light Industry	—	—	—	—	—	—	—	—	—	—	—	7.35	0.00	7.35	0.73	0.00	—	25.7
Automobile Care Center	—	—	—	—	—	—	—	—	—	—	—	28.8	0.00	28.8	2.88	0.00	—	101
Parking Lot	—	—	—	—	—	—	—	—	—	—	—	0.00	0.00	0.00	0.00	0.00	—	0.00
Total	—	—	—	—	—	—	—	—	—	—	—	36.2	0.00	36.2	3.62	0.00	—	127
Annual	—	—	—	—	—	—	—	—	—	—	—	—	—	—	—	—	—	—
General Light Industry	—	—	—	—	—	—	—	—	—	—	—	1.22	0.00	1.22	0.12	0.00	—	4.26

Attachment 9

Automobile Care Center	—	—	—	—	—	—	—	—	—	—	—	4.77	0.00	4.77	0.48	0.00	—	16.7
Parking Lot	—	—	—	—	—	—	—	—	—	—	—	0.00	0.00	0.00	0.00	0.00	—	0.00
Total	—	—	—	—	—	—	—	—	—	—	—	5.99	0.00	5.99	0.60	0.00	—	21.0

4.6. Refrigerant Emissions by Land Use

4.6.1. Unmitigated

Criteria Pollutants (lb/day for daily, ton/yr for annual) and GHGs (lb/day for daily, MT/yr for annual)

Land Use	TOG	ROG	NOx	CO	SO2	PM10E	PM10D	PM10T	PM2.5E	PM2.5D	PM2.5T	BCO2	NBCO2	CO2T	CH4	N2O	R	CO2e
Daily, Summer (Max)	—	—	—	—	—	—	—	—	—	—	—	—	—	—	—	—	—	—
General Light Industry	—	—	—	—	—	—	—	—	—	—	—	—	—	—	—	—	2.86	2.86
Automobile Care Center	—	—	—	—	—	—	—	—	—	—	—	—	—	—	—	—	2,902	2,902
Total	—	—	—	—	—	—	—	—	—	—	—	—	—	—	—	—	2,905	2,905
Daily, Winter (Max)	—	—	—	—	—	—	—	—	—	—	—	—	—	—	—	—	—	—
General Light Industry	—	—	—	—	—	—	—	—	—	—	—	—	—	—	—	—	2.86	2.86
Automobile Care Center	—	—	—	—	—	—	—	—	—	—	—	—	—	—	—	—	2,902	2,902

Attachment 9

Total	—	—	—	—	—	—	—	—	—	—	—	—	—	—	—	—	2,905	2,905
Annual	—	—	—	—	—	—	—	—	—	—	—	—	—	—	—	—	—	—
General Light Industry	—	—	—	—	—	—	—	—	—	—	—	—	—	—	—	—	0.47	0.47
Automobile Care Center	—	—	—	—	—	—	—	—	—	—	—	—	—	—	—	—	481	481
Total	—	—	—	—	—	—	—	—	—	—	—	—	—	—	—	—	481	481

4.6.2. Mitigated

Criteria Pollutants (lb/day for daily, ton/yr for annual) and GHGs (lb/day for daily, MT/yr for annual)

Land Use	TOG	ROG	NOx	CO	SO2	PM10E	PM10D	PM10T	PM2.5E	PM2.5D	PM2.5T	BCO2	NBCO2	CO2T	CH4	N2O	R	CO2e
Daily, Summer (Max)	—	—	—	—	—	—	—	—	—	—	—	—	—	—	—	—	—	—
General Light Industry	—	—	—	—	—	—	—	—	—	—	—	—	—	—	—	—	2.86	2.86
Automobile Care Center	—	—	—	—	—	—	—	—	—	—	—	—	—	—	—	—	2,902	2,902
Total	—	—	—	—	—	—	—	—	—	—	—	—	—	—	—	—	2,905	2,905
Daily, Winter (Max)	—	—	—	—	—	—	—	—	—	—	—	—	—	—	—	—	—	—
General Light Industry	—	—	—	—	—	—	—	—	—	—	—	—	—	—	—	—	2.86	2.86

Attachment 9

Automobile Care Center	—	—	—	—	—	—	—	—	—	—	—	—	—	—	—	—	2,902	2,902
Total	—	—	—	—	—	—	—	—	—	—	—	—	—	—	—	—	2,905	2,905
Annual	—	—	—	—	—	—	—	—	—	—	—	—	—	—	—	—	—	—
General Light Industry	—	—	—	—	—	—	—	—	—	—	—	—	—	—	—	—	0.47	0.47
Automobile Care Center	—	—	—	—	—	—	—	—	—	—	—	—	—	—	—	—	481	481
Total	—	—	—	—	—	—	—	—	—	—	—	—	—	—	—	—	481	481

4.7. Offroad Emissions By Equipment Type

4.7.1. Unmitigated

Criteria Pollutants (lb/day for daily, ton/yr for annual) and GHGs (lb/day for daily, MT/yr for annual)

Equipment Type	TOG	ROG	NOx	CO	SO2	PM10E	PM10D	PM10T	PM2.5E	PM2.5D	PM2.5T	BCO2	NBCO2	CO2T	CH4	N2O	R	CO2e
Daily, Summer (Max)	—	—	—	—	—	—	—	—	—	—	—	—	—	—	—	—	—	—
Total	—	—	—	—	—	—	—	—	—	—	—	—	—	—	—	—	—	—
Daily, Winter (Max)	—	—	—	—	—	—	—	—	—	—	—	—	—	—	—	—	—	—
Total	—	—	—	—	—	—	—	—	—	—	—	—	—	—	—	—	—	—
Annual	—	—	—	—	—	—	—	—	—	—	—	—	—	—	—	—	—	—
Total	—	—	—	—	—	—	—	—	—	—	—	—	—	—	—	—	—	—

Attachment 9

4.7.2. Mitigated

Criteria Pollutants (lb/day for daily, ton/yr for annual) and GHGs (lb/day for daily, MT/yr for annual)

Equipment Type	TOG	ROG	NOx	CO	SO2	PM10E	PM10D	PM10T	PM2.5E	PM2.5D	PM2.5T	BCO2	NBCO2	CO2T	CH4	N2O	R	CO2e
Daily, Summer (Max)	—	—	—	—	—	—	—	—	—	—	—	—	—	—	—	—	—	—
Total	—	—	—	—	—	—	—	—	—	—	—	—	—	—	—	—	—	—
Daily, Winter (Max)	—	—	—	—	—	—	—	—	—	—	—	—	—	—	—	—	—	—
Total	—	—	—	—	—	—	—	—	—	—	—	—	—	—	—	—	—	—
Annual	—	—	—	—	—	—	—	—	—	—	—	—	—	—	—	—	—	—
Total	—	—	—	—	—	—	—	—	—	—	—	—	—	—	—	—	—	—

4.8. Stationary Emissions By Equipment Type

4.8.1. Unmitigated

Criteria Pollutants (lb/day for daily, ton/yr for annual) and GHGs (lb/day for daily, MT/yr for annual)

Equipment Type	TOG	ROG	NOx	CO	SO2	PM10E	PM10D	PM10T	PM2.5E	PM2.5D	PM2.5T	BCO2	NBCO2	CO2T	CH4	N2O	R	CO2e
Daily, Summer (Max)	—	—	—	—	—	—	—	—	—	—	—	—	—	—	—	—	—	—
Total	—	—	—	—	—	—	—	—	—	—	—	—	—	—	—	—	—	—
Daily, Winter (Max)	—	—	—	—	—	—	—	—	—	—	—	—	—	—	—	—	—	—
Total	—	—	—	—	—	—	—	—	—	—	—	—	—	—	—	—	—	—

Attachment 9

Annual	—	—	—	—	—	—	—	—	—	—	—	—	—	—	—	—	—	—
Total	—	—	—	—	—	—	—	—	—	—	—	—	—	—	—	—	—	—

4.8.2. Mitigated

Criteria Pollutants (lb/day for daily, ton/yr for annual) and GHGs (lb/day for daily, MT/yr for annual)

Equipment Type	TOG	ROG	NOx	CO	SO2	PM10E	PM10D	PM10T	PM2.5E	PM2.5D	PM2.5T	BCO2	NBCO2	CO2T	CH4	N2O	R	CO2e
Daily, Summer (Max)	—	—	—	—	—	—	—	—	—	—	—	—	—	—	—	—	—	—
Total	—	—	—	—	—	—	—	—	—	—	—	—	—	—	—	—	—	—
Daily, Winter (Max)	—	—	—	—	—	—	—	—	—	—	—	—	—	—	—	—	—	—
Total	—	—	—	—	—	—	—	—	—	—	—	—	—	—	—	—	—	—
Annual	—	—	—	—	—	—	—	—	—	—	—	—	—	—	—	—	—	—
Total	—	—	—	—	—	—	—	—	—	—	—	—	—	—	—	—	—	—

4.9. User Defined Emissions By Equipment Type

4.9.1. Unmitigated

Criteria Pollutants (lb/day for daily, ton/yr for annual) and GHGs (lb/day for daily, MT/yr for annual)

Equipment Type	TOG	ROG	NOx	CO	SO2	PM10E	PM10D	PM10T	PM2.5E	PM2.5D	PM2.5T	BCO2	NBCO2	CO2T	CH4	N2O	R	CO2e
Daily, Summer (Max)	—	—	—	—	—	—	—	—	—	—	—	—	—	—	—	—	—	—
Total	—	—	—	—	—	—	—	—	—	—	—	—	—	—	—	—	—	—

Attachment 9

Daily, Winter (Max)	—	—	—	—	—	—	—	—	—	—	—	—	—	—	—	—	—	—
Total	—	—	—	—	—	—	—	—	—	—	—	—	—	—	—	—	—	—
Annual	—	—	—	—	—	—	—	—	—	—	—	—	—	—	—	—	—	—
Total	—	—	—	—	—	—	—	—	—	—	—	—	—	—	—	—	—	—

4.9.2. Mitigated

Criteria Pollutants (lb/day for daily, ton/yr for annual) and GHGs (lb/day for daily, MT/yr for annual)

Equipment Type	TOG	ROG	NOx	CO	SO2	PM10E	PM10D	PM10T	PM2.5E	PM2.5D	PM2.5T	BCO2	NBCO2	CO2T	CH4	N2O	R	CO2e
Daily, Summer (Max)	—	—	—	—	—	—	—	—	—	—	—	—	—	—	—	—	—	—
Total	—	—	—	—	—	—	—	—	—	—	—	—	—	—	—	—	—	—
Daily, Winter (Max)	—	—	—	—	—	—	—	—	—	—	—	—	—	—	—	—	—	—
Total	—	—	—	—	—	—	—	—	—	—	—	—	—	—	—	—	—	—
Annual	—	—	—	—	—	—	—	—	—	—	—	—	—	—	—	—	—	—
Total	—	—	—	—	—	—	—	—	—	—	—	—	—	—	—	—	—	—

4.10. Soil Carbon Accumulation By Vegetation Type

4.10.1. Soil Carbon Accumulation By Vegetation Type - Unmitigated

Criteria Pollutants (lb/day for daily, ton/yr for annual) and GHGs (lb/day for daily, MT/yr for annual)

Vegetation	TOG	ROG	NOx	CO	SO2	PM10E	PM10D	PM10T	PM2.5E	PM2.5D	PM2.5T	BCO2	NBCO2	CO2T	CH4	N2O	R	CO2e
------------	-----	-----	-----	----	-----	-------	-------	-------	--------	--------	--------	------	-------	------	-----	-----	---	------

Attachment 9

Daily, Summer (Max)	—	—	—	—	—	—	—	—	—	—	—	—	—	—	—	—	—	—
Total	—	—	—	—	—	—	—	—	—	—	—	—	—	—	—	—	—	—
Daily, Winter (Max)	—	—	—	—	—	—	—	—	—	—	—	—	—	—	—	—	—	—
Total	—	—	—	—	—	—	—	—	—	—	—	—	—	—	—	—	—	—
Annual	—	—	—	—	—	—	—	—	—	—	—	—	—	—	—	—	—	—
Total	—	—	—	—	—	—	—	—	—	—	—	—	—	—	—	—	—	—

4.10.2. Above and Belowground Carbon Accumulation by Land Use Type - Unmitigated

Criteria Pollutants (lb/day for daily, ton/yr for annual) and GHGs (lb/day for daily, MT/yr for annual)

Land Use	TOG	ROG	NOx	CO	SO2	PM10E	PM10D	PM10T	PM2.5E	PM2.5D	PM2.5T	BCO2	NBCO2	CO2T	CH4	N2O	R	CO2e
Daily, Summer (Max)	—	—	—	—	—	—	—	—	—	—	—	—	—	—	—	—	—	—
Total	—	—	—	—	—	—	—	—	—	—	—	—	—	—	—	—	—	—
Daily, Winter (Max)	—	—	—	—	—	—	—	—	—	—	—	—	—	—	—	—	—	—
Total	—	—	—	—	—	—	—	—	—	—	—	—	—	—	—	—	—	—
Annual	—	—	—	—	—	—	—	—	—	—	—	—	—	—	—	—	—	—
Total	—	—	—	—	—	—	—	—	—	—	—	—	—	—	—	—	—	—

4.10.3. Avoided and Sequestered Emissions by Species - Unmitigated

Criteria Pollutants (lb/day for daily, ton/yr for annual) and GHGs (lb/day for daily, MT/yr for annual)

Species	TOG	ROG	NOx	CO	SO2	PM10E	PM10D	PM10T	PM2.5E	PM2.5D	PM2.5T	BCO2	NBCO2	CO2T	CH4	N2O	R	CO2e
---------	-----	-----	-----	----	-----	-------	-------	-------	--------	--------	--------	------	-------	------	-----	-----	---	------

Attachment 9

Daily, Summer (Max)	---	---	---	---	---	---	---	---	---	---	---	---	---	---	---	---	---	---	---
Avoided	---	---	---	---	---	---	---	---	---	---	---	---	---	---	---	---	---	---	---
Oak, interior live	---	---	---	---	---	NaN	NaN	NaN	NaN	NaN	NaN	---	NaN	NaN	---	---	---	---	NaN
Planetree, London	---	---	---	---	---	NaN	NaN	NaN	NaN	NaN	NaN	---	---	---	---	---	---	---	---
Pistache, Chinese	---	---	---	---	---	NaN	NaN	NaN	NaN	NaN	NaN	---	---	---	---	---	---	---	---
Subtotal	---	---	---	---	---	NaN	NaN	NaN	NaN	NaN	NaN	---	NaN	NaN	---	---	---	---	NaN
Sequestered	---	---	---	---	---	---	---	---	---	---	---	---	---	---	---	---	---	---	---
Subtotal	---	---	---	---	---	---	---	---	---	---	---	---	---	---	---	---	---	---	---
Removed	---	---	---	---	---	---	---	---	---	---	---	---	---	---	---	---	---	---	---
Oak, interior live	---	---	---	---	---	NaN	NaN	NaN	NaN	NaN	NaN	---	---	---	---	---	---	---	---
Planetree, London	---	---	---	---	---	NaN	NaN	NaN	NaN	NaN	NaN	---	---	---	---	---	---	---	---
Pistache, Chinese	---	---	---	---	---	NaN	NaN	NaN	NaN	NaN	NaN	---	---	---	---	---	---	---	---
Subtotal	---	---	---	---	---	NaN	NaN	NaN	NaN	NaN	NaN	---	---	---	---	---	---	---	---
---	---	---	---	---	---	---	---	---	---	---	---	---	---	---	---	---	---	---	---
Total	---	---	---	---	---	NaN	NaN	NaN	NaN	NaN	NaN	---	NaN	NaN	---	---	---	---	NaN
Daily, Winter (Max)	---	---	---	---	---	---	---	---	---	---	---	---	---	---	---	---	---	---	---
Avoided	---	---	---	---	---	---	---	---	---	---	---	---	---	---	---	---	---	---	---

Attachment 9

Oak, interior live	—	—	—	—	—	NaN	NaN	NaN	NaN	NaN	NaN	—	NaN	NaN	—	—	—	NaN
Planetree, London	—	—	—	—	—	NaN	NaN	NaN	NaN	NaN	NaN	—	—	—	—	—	—	—
Pistache, Chinese	—	—	—	—	—	NaN	NaN	NaN	NaN	NaN	NaN	—	—	—	—	—	—	—
Subtotal	—	—	—	—	—	NaN	NaN	NaN	NaN	NaN	NaN	—	NaN	NaN	—	—	—	NaN
Sequestered	—	—	—	—	—	—	—	—	—	—	—	—	—	—	—	—	—	—
Subtotal	—	—	—	—	—	—	—	—	—	—	—	—	—	—	—	—	—	—
Removed	—	—	—	—	—	—	—	—	—	—	—	—	—	—	—	—	—	—
Oak, interior live	—	—	—	—	—	NaN	NaN	NaN	NaN	NaN	NaN	—	—	—	—	—	—	—
Planetree, London	—	—	—	—	—	NaN	NaN	NaN	NaN	NaN	NaN	—	—	—	—	—	—	—
Pistache, Chinese	—	—	—	—	—	NaN	NaN	NaN	NaN	NaN	NaN	—	—	—	—	—	—	—
Subtotal	—	—	—	—	—	NaN	NaN	NaN	NaN	NaN	NaN	—	—	—	—	—	—	—
—	—	—	—	—	—	—	—	—	—	—	—	—	—	—	—	—	—	—
Total	—	—	—	—	—	NaN	NaN	NaN	NaN	NaN	NaN	—	NaN	NaN	—	—	—	NaN
Annual	—	—	—	—	—	—	—	—	—	—	—	—	—	—	—	—	—	—
Avoided	—	—	—	—	—	—	—	—	—	—	—	—	—	—	—	—	—	—
Oak, interior live	—	—	—	—	—	NaN	NaN	NaN	NaN	NaN	NaN	—	NaN	NaN	—	—	—	NaN
Planetree, London	—	—	—	—	—	NaN	NaN	NaN	NaN	NaN	NaN	—	—	—	—	—	—	—

Attachment 9

Pistache, Chinese	—	—	—	—	—	NaN	NaN	NaN	NaN	NaN	NaN	—	—	—	—	—	—	—
Subtotal	—	—	—	—	—	NaN	NaN	NaN	NaN	NaN	NaN	—	NaN	NaN	—	—	—	NaN
Sequestered	—	—	—	—	—	—	—	—	—	—	—	—	—	—	—	—	—	—
Subtotal	—	—	—	—	—	—	—	—	—	—	—	—	—	—	—	—	—	—
Removed	—	—	—	—	—	—	—	—	—	—	—	—	—	—	—	—	—	—
Oak, interior live	—	—	—	—	—	NaN	NaN	NaN	NaN	NaN	NaN	—	—	—	—	—	—	—
Planetree, London	—	—	—	—	—	NaN	NaN	NaN	NaN	NaN	NaN	—	—	—	—	—	—	—
Pistache, Chinese	—	—	—	—	—	NaN	NaN	NaN	NaN	NaN	NaN	—	—	—	—	—	—	—
Subtotal	—	—	—	—	—	NaN	NaN	NaN	NaN	NaN	NaN	—	—	—	—	—	—	—
—	—	—	—	—	—	—	—	—	—	—	—	—	—	—	—	—	—	—
Total	—	—	—	—	—	NaN	NaN	NaN	NaN	NaN	NaN	—	NaN	NaN	—	—	—	NaN

4.10.4. Soil Carbon Accumulation By Vegetation Type - Mitigated

Criteria Pollutants (lb/day for daily, ton/yr for annual) and GHGs (lb/day for daily, MT/yr for annual)

Vegetation	TOG	ROG	NOx	CO	SO2	PM10E	PM10D	PM10T	PM2.5E	PM2.5D	PM2.5T	BCO2	NBCO2	CO2T	CH4	N2O	R	CO2e	
Daily, Summer (Max)	—	—	—	—	—	—	—	—	—	—	—	—	—	—	—	—	—	—	—
Total	—	—	—	—	—	—	—	—	—	—	—	—	—	—	—	—	—	—	—
Daily, Winter (Max)	—	—	—	—	—	—	—	—	—	—	—	—	—	—	—	—	—	—	—
Total	—	—	—	—	—	—	—	—	—	—	—	—	—	—	—	—	—	—	—

Attachment 9

Annual	—	—	—	—	—	—	—	—	—	—	—	—	—	—	—	—	—	—
Total	—	—	—	—	—	—	—	—	—	—	—	—	—	—	—	—	—	—

4.10.5. Above and Belowground Carbon Accumulation by Land Use Type - Mitigated

Criteria Pollutants (lb/day for daily, ton/yr for annual) and GHGs (lb/day for daily, MT/yr for annual)

Land Use	TOG	ROG	NOx	CO	SO2	PM10E	PM10D	PM10T	PM2.5E	PM2.5D	PM2.5T	BCO2	NBCO2	CO2T	CH4	N2O	R	CO2e
Daily, Summer (Max)	—	—	—	—	—	—	—	—	—	—	—	—	—	—	—	—	—	—
Total	—	—	—	—	—	—	—	—	—	—	—	—	—	—	—	—	—	—
Daily, Winter (Max)	—	—	—	—	—	—	—	—	—	—	—	—	—	—	—	—	—	—
Total	—	—	—	—	—	—	—	—	—	—	—	—	—	—	—	—	—	—
Annual	—	—	—	—	—	—	—	—	—	—	—	—	—	—	—	—	—	—
Total	—	—	—	—	—	—	—	—	—	—	—	—	—	—	—	—	—	—

4.10.6. Avoided and Sequestered Emissions by Species - Mitigated

Criteria Pollutants (lb/day for daily, ton/yr for annual) and GHGs (lb/day for daily, MT/yr for annual)

Species	TOG	ROG	NOx	CO	SO2	PM10E	PM10D	PM10T	PM2.5E	PM2.5D	PM2.5T	BCO2	NBCO2	CO2T	CH4	N2O	R	CO2e
Daily, Summer (Max)	—	—	—	—	—	—	—	—	—	—	—	—	—	—	—	—	—	—
Avoided	—	—	—	—	—	—	—	—	—	—	—	—	—	—	—	—	—	—
Oak, interior live	—	—	—	—	—	NaN	NaN	NaN	NaN	NaN	NaN	—	NaN	NaN	—	—	—	NaN
Planetree, London	—	—	—	—	—	NaN	NaN	NaN	NaN	NaN	NaN	—	—	—	—	—	—	—

Attachment 9

undefine	—	—	—	—	—	NaN	NaN	NaN	NaN	NaN	NaN	—	—	—	—	—	—	—
Pistache, Chinese	—	—	—	—	—	NaN	NaN	NaN	NaN	NaN	NaN	—	—	—	—	—	—	—
Subtotal	—	—	—	—	—	NaN	NaN	NaN	NaN	NaN	NaN	—	NaN	NaN	—	—	—	NaN
Sequestered	—	—	—	—	—	—	—	—	—	—	—	—	—	—	—	—	—	—
Subtotal	—	—	—	—	—	—	—	—	—	—	—	—	—	—	—	—	—	—
Removed	—	—	—	—	—	—	—	—	—	—	—	—	—	—	—	—	—	—
Oak, interior live	—	—	—	—	—	NaN	NaN	NaN	NaN	NaN	NaN	—	—	—	—	—	—	—
Planetree, London	—	—	—	—	—	NaN	NaN	NaN	NaN	NaN	NaN	—	—	—	—	—	—	—
undefine d	—	—	—	—	—	NaN	NaN	NaN	NaN	NaN	NaN	—	—	—	—	—	—	—
Pistache, Chinese	—	—	—	—	—	NaN	NaN	NaN	NaN	NaN	NaN	—	—	—	—	—	—	—
Subtotal	—	—	—	—	—	NaN	NaN	NaN	NaN	NaN	NaN	—	—	—	—	—	—	—
—	—	—	—	—	—	—	—	—	—	—	—	—	—	—	—	—	—	—
Total	—	—	—	—	—	NaN	NaN	NaN	NaN	NaN	NaN	—	NaN	NaN	—	—	—	NaN
Daily, Winter (Max)	—	—	—	—	—	—	—	—	—	—	—	—	—	—	—	—	—	—
Avoided	—	—	—	—	—	—	—	—	—	—	—	—	—	—	—	—	—	—
Oak, interior live	—	—	—	—	—	NaN	NaN	NaN	NaN	NaN	NaN	—	NaN	NaN	—	—	—	NaN
Planetree, London	—	—	—	—	—	NaN	NaN	NaN	NaN	NaN	NaN	—	—	—	—	—	—	—

Attachment 9

undefined	—	—	—	—	—	NaN	NaN	NaN	NaN	NaN	NaN	—	—	—	—	—	—	—
Pistache, Chinese	—	—	—	—	—	NaN	NaN	NaN	NaN	NaN	NaN	—	—	—	—	—	—	—
Subtotal	—	—	—	—	—	NaN	NaN	NaN	NaN	NaN	NaN	—	NaN	NaN	—	—	—	NaN
Sequestered	—	—	—	—	—	—	—	—	—	—	—	—	—	—	—	—	—	—
Subtotal	—	—	—	—	—	—	—	—	—	—	—	—	—	—	—	—	—	—
Removed	—	—	—	—	—	—	—	—	—	—	—	—	—	—	—	—	—	—
Oak, interior live	—	—	—	—	—	NaN	NaN	NaN	NaN	NaN	NaN	—	—	—	—	—	—	—
Planetree, London	—	—	—	—	—	NaN	NaN	NaN	NaN	NaN	NaN	—	—	—	—	—	—	—
undefined	—	—	—	—	—	NaN	NaN	NaN	NaN	NaN	NaN	—	—	—	—	—	—	—
Pistache, Chinese	—	—	—	—	—	NaN	NaN	NaN	NaN	NaN	NaN	—	—	—	—	—	—	—
Subtotal	—	—	—	—	—	NaN	NaN	NaN	NaN	NaN	NaN	—	—	—	—	—	—	—
—	—	—	—	—	—	—	—	—	—	—	—	—	—	—	—	—	—	—
Total	—	—	—	—	—	NaN	NaN	NaN	NaN	NaN	NaN	—	NaN	NaN	—	—	—	NaN
Annual	—	—	—	—	—	—	—	—	—	—	—	—	—	—	—	—	—	—
Avoided	—	—	—	—	—	—	—	—	—	—	—	—	—	—	—	—	—	—
Oak, interior live	—	—	—	—	—	NaN	NaN	NaN	NaN	NaN	NaN	—	NaN	NaN	—	—	—	NaN
Planetree, London	—	—	—	—	—	NaN	NaN	NaN	NaN	NaN	NaN	—	—	—	—	—	—	—
undefined	—	—	—	—	—	NaN	NaN	NaN	NaN	NaN	NaN	—	—	—	—	—	—	—

Attachment 9

Pistache, Chinese	—	—	—	—	—	NaN	NaN	NaN	NaN	NaN	NaN	—	—	—	—	—	—	—
Subtotal	—	—	—	—	—	NaN	NaN	NaN	NaN	NaN	NaN	—	NaN	NaN	—	—	—	NaN
Sequestered	—	—	—	—	—	—	—	—	—	—	—	—	—	—	—	—	—	—
Subtotal	—	—	—	—	—	—	—	—	—	—	—	—	—	—	—	—	—	—
Removed	—	—	—	—	—	—	—	—	—	—	—	—	—	—	—	—	—	—
Oak, interior live	—	—	—	—	—	NaN	NaN	NaN	NaN	NaN	NaN	—	—	—	—	—	—	—
Planetree, London	—	—	—	—	—	NaN	NaN	NaN	NaN	NaN	NaN	—	—	—	—	—	—	—
undefined	—	—	—	—	—	NaN	NaN	NaN	NaN	NaN	NaN	—	—	—	—	—	—	—
Pistache, Chinese	—	—	—	—	—	NaN	NaN	NaN	NaN	NaN	NaN	—	—	—	—	—	—	—
Subtotal	—	—	—	—	—	NaN	NaN	NaN	NaN	NaN	NaN	—	—	—	—	—	—	—
—	—	—	—	—	—	—	—	—	—	—	—	—	—	—	—	—	—	—
Total	—	—	—	—	—	NaN	NaN	NaN	NaN	NaN	NaN	—	NaN	NaN	—	—	—	NaN

5. Activity Data

5.1. Construction Schedule

Phase Name	Phase Type	Start Date	End Date	Days Per Week	Work Days per Phase	Phase Description
Site Preparation	Site Preparation	8/30/2023	9/6/2023	5.00	5.00	—
Grading	Grading	9/7/2023	9/18/2023	5.00	8.00	—
Building Construction	Building Construction	9/19/2023	8/6/2024	5.00	230	—
Paving	Paving	8/7/2024	9/1/2024	5.00	18.0	—

Architectural Coating	Architectural Coating	9/2/2024	9/27/2024	5.00	18.0	—
-----------------------	-----------------------	----------	-----------	------	------	---

5.2. Off-Road Equipment

5.2.1. Unmitigated

Phase Name	Equipment Type	Fuel Type	Engine Tier	Number per Day	Hours Per Day	Horsepower	Load Factor
Site Preparation	Rubber Tired Dozers	Diesel	Average	3.00	8.00	367	0.40
Site Preparation	Tractors/Loaders/Backhoes	Diesel	Average	4.00	8.00	84.0	0.37
Grading	Excavators	Diesel	Average	1.00	8.00	36.0	0.38
Grading	Graders	Diesel	Average	1.00	8.00	148	0.41
Grading	Rubber Tired Dozers	Diesel	Average	1.00	8.00	367	0.40
Grading	Tractors/Loaders/Backhoes	Diesel	Average	3.00	8.00	84.0	0.37
Building Construction	Cranes	Diesel	Average	1.00	7.00	367	0.29
Building Construction	Forklifts	Diesel	Average	3.00	8.00	82.0	0.20
Building Construction	Generator Sets	Diesel	Average	1.00	8.00	14.0	0.74
Building Construction	Tractors/Loaders/Backhoes	Diesel	Average	3.00	7.00	84.0	0.37
Building Construction	Welders	Diesel	Average	1.00	8.00	46.0	0.45
Paving	Cement and Mortar Mixers	Diesel	Average	2.00	6.00	10.0	0.56
Paving	Pavers	Diesel	Average	1.00	8.00	81.0	0.42
Paving	Paving Equipment	Diesel	Average	2.00	6.00	89.0	0.36
Paving	Rollers	Diesel	Average	2.00	6.00	36.0	0.38
Paving	Tractors/Loaders/Backhoes	Diesel	Average	1.00	8.00	84.0	0.37
Architectural Coating	Air Compressors	Diesel	Average	1.00	6.00	37.0	0.48

5.2.2. Mitigated

Phase Name	Equipment Type	Fuel Type	Engine Tier	Number per Day	Hours Per Day	Horsepower	Load Factor
Site Preparation	Rubber Tired Dozers	Diesel	Average	3.00	8.00	367	0.40
Site Preparation	Tractors/Loaders/Backhoes	Diesel	Average	4.00	8.00	84.0	0.37
Grading	Excavators	Diesel	Average	1.00	8.00	36.0	0.38
Grading	Graders	Diesel	Average	1.00	8.00	148	0.41
Grading	Rubber Tired Dozers	Diesel	Average	1.00	8.00	367	0.40
Grading	Tractors/Loaders/Backhoes	Diesel	Average	3.00	8.00	84.0	0.37
Building Construction	Cranes	Diesel	Average	1.00	7.00	367	0.29
Building Construction	Forklifts	Diesel	Average	3.00	8.00	82.0	0.20
Building Construction	Generator Sets	Diesel	Average	1.00	8.00	14.0	0.74
Building Construction	Tractors/Loaders/Backhoes	Diesel	Average	3.00	7.00	84.0	0.37
Building Construction	Welders	Diesel	Average	1.00	8.00	46.0	0.45
Paving	Cement and Mortar Mixers	Diesel	Average	2.00	6.00	10.0	0.56
Paving	Pavers	Diesel	Average	1.00	8.00	81.0	0.42
Paving	Paving Equipment	Diesel	Average	2.00	6.00	89.0	0.36
Paving	Rollers	Diesel	Average	2.00	6.00	36.0	0.38
Paving	Tractors/Loaders/Backhoes	Diesel	Average	1.00	8.00	84.0	0.37
Architectural Coating	Air Compressors	Diesel	Average	1.00	6.00	37.0	0.48

5.3. Construction Vehicles**5.3.1. Unmitigated**

Phase Name	Trip Type	One-Way Trips per Day	Miles per Trip	Vehicle Mix
------------	-----------	-----------------------	----------------	-------------

Attachment 9

Site Preparation	—	—	—	—
Site Preparation	Worker	17.5	8.10	LDA,LDT1,LDT2
Site Preparation	Vendor	—	6.90	HHDT,MHDT
Site Preparation	Hauling	0.00	20.0	HHDT
Site Preparation	Onsite truck	—	—	HHDT
Grading	—	—	—	—
Grading	Worker	15.0	8.10	LDA,LDT1,LDT2
Grading	Vendor	—	6.90	HHDT,MHDT
Grading	Hauling	36.0	20.0	HHDT
Grading	Onsite truck	—	—	HHDT
Building Construction	—	—	—	—
Building Construction	Worker	9.10	8.10	LDA,LDT1,LDT2
Building Construction	Vendor	4.10	6.90	HHDT,MHDT
Building Construction	Hauling	0.00	20.0	HHDT
Building Construction	Onsite truck	—	—	HHDT
Paving	—	—	—	—
Paving	Worker	20.0	8.10	LDA,LDT1,LDT2
Paving	Vendor	—	6.90	HHDT,MHDT
Paving	Hauling	0.00	20.0	HHDT
Paving	Onsite truck	—	—	HHDT
Architectural Coating	—	—	—	—
Architectural Coating	Worker	1.82	8.10	LDA,LDT1,LDT2
Architectural Coating	Vendor	—	6.90	HHDT,MHDT
Architectural Coating	Hauling	0.00	20.0	HHDT
Architectural Coating	Onsite truck	—	—	HHDT

5.3.2. Mitigated

Attachment 9

Phase Name	Trip Type	One-Way Trips per Day	Miles per Trip	Vehicle Mix
Site Preparation	—	—	—	—
Site Preparation	Worker	17.5	8.10	LDA,LDT1,LDT2
Site Preparation	Vendor	—	6.90	HHDT,MHDT
Site Preparation	Hauling	0.00	20.0	HHDT
Site Preparation	Onsite truck	—	—	HHDT
Grading	—	—	—	—
Grading	Worker	15.0	8.10	LDA,LDT1,LDT2
Grading	Vendor	—	6.90	HHDT,MHDT
Grading	Hauling	36.0	20.0	HHDT
Grading	Onsite truck	—	—	HHDT
Building Construction	—	—	—	—
Building Construction	Worker	9.10	8.10	LDA,LDT1,LDT2
Building Construction	Vendor	4.10	6.90	HHDT,MHDT
Building Construction	Hauling	0.00	20.0	HHDT
Building Construction	Onsite truck	—	—	HHDT
Paving	—	—	—	—
Paving	Worker	20.0	8.10	LDA,LDT1,LDT2
Paving	Vendor	—	6.90	HHDT,MHDT
Paving	Hauling	0.00	20.0	HHDT
Paving	Onsite truck	—	—	HHDT
Architectural Coating	—	—	—	—
Architectural Coating	Worker	1.82	8.10	LDA,LDT1,LDT2
Architectural Coating	Vendor	—	6.90	HHDT,MHDT
Architectural Coating	Hauling	0.00	20.0	HHDT
Architectural Coating	Onsite truck	—	—	HHDT

5.4. Vehicles

5.4.1. Construction Vehicle Control Strategies

Non-applicable. No control strategies activated by user.

5.5. Architectural Coatings

Phase Name	Residential Interior Area Coated (sq ft)	Residential Exterior Area Coated (sq ft)	Non-Residential Interior Area Coated (sq ft)	Non-Residential Exterior Area Coated (sq ft)	Parking Area Coated (sq ft)
Architectural Coating	0.00	0.00	43,381	14,460	7,841

5.6. Dust Mitigation

5.6.1. Construction Earthmoving Activities

Phase Name	Material Imported (cy)	Material Exported (cy)	Acres Graded (acres)	Material Demolished (Building Square Footage)	Acres Paved (acres)
Grading	0.00	0.00	0.00	25,000	—
Paving	0.00	0.00	0.00	0.00	3.00

5.6.2. Construction Earthmoving Control Strategies

Control Strategies Applied	Frequency (per day)	PM10 Reduction	PM2.5 Reduction
Water Exposed Area	2	61%	61%
Water Demolished Area	2	36%	36%

5.7. Construction Paving

Land Use	Area Paved (acres)	% Asphalt
General Light Industry	0.00	0%
Automobile Care Center	0.00	0%

Parking Lot	3.00	100%
-------------	------	------

5.8. Construction Electricity Consumption and Emissions Factors

kWh per Year and Emission Factor (lb/MWh)

Year	kWh per Year	CO2	CH4	N2O
2023	0.00	204	0.03	< 0.005
2024	0.00	204	0.03	< 0.005

5.9. Operational Mobile Sources

5.9.1. Unmitigated

Land Use Type	Trips/Weekday	Trips/Saturday	Trips/Sunday	Trips/Year	VMT/Weekday	VMT/Saturday	VMT/Sunday	VMT/Year
Total all Land Uses	178	0.00	0.00	0.00	38.0	0.00	0.00	0.00

5.9.2. Mitigated

Land Use Type	Trips/Weekday	Trips/Saturday	Trips/Sunday	Trips/Year	VMT/Weekday	VMT/Saturday	VMT/Sunday	VMT/Year
Total all Land Uses	178	0.00	0.00	0.00	38.0	0.00	0.00	0.00

5.10. Operational Area Sources

5.10.1. Hearths

5.10.1.1. Unmitigated

5.10.1.2. Mitigated

5.10.2. Architectural Coatings

Attachment 9

Residential Interior Area Coated (sq ft)	Residential Exterior Area Coated (sq ft)	Non-Residential Interior Area Coated (sq ft)	Non-Residential Exterior Area Coated (sq ft)	Parking Area Coated (sq ft)
0	0.00	43,381	14,460	7,841

5.10.3. Landscape Equipment

Season	Unit	Value
Snow Days	day/yr	0.00
Summer Days	day/yr	330

5.10.4. Landscape Equipment - Mitigated

Season	Unit	Value
Snow Days	day/yr	0.00
Summer Days	day/yr	330

5.11. Operational Energy Consumption

5.11.1. Unmitigated

Electricity (kWh/yr) and CO2 and CH4 and N2O and Natural Gas (kBTU/yr)

Land Use	Electricity (kWh/yr)	CO2	CH4	N2O	Natural Gas (kBTU/yr)
General Light Industry	110,948	204	0.0330	0.0040	464,137
Automobile Care Center	141,206	204	0.0330	0.0040	590,720
Parking Lot	114,476	204	0.0330	0.0040	0.00

5.11.2. Mitigated

Electricity (kWh/yr) and CO2 and CH4 and N2O and Natural Gas (kBTU/yr)

Land Use	Electricity (kWh/yr)	CO2	CH4	N2O	Natural Gas (kBTU/yr)
General Light Industry	110,948	204	0.0330	0.0040	464,137

Attachment 9

Automobile Care Center	141,206	204	0.0330	0.0040	590,720
Parking Lot	114,476	204	0.0330	0.0040	0.00

5.12. Operational Water and Wastewater Consumption**5.12.1. Unmitigated**

Land Use	Indoor Water (gal/year)	Outdoor Water (gal/year)
General Light Industry	2,543,750	547,924
Automobile Care Center	1,317,136	13.6
Parking Lot	0.00	13.6

5.12.2. Mitigated

Land Use	Indoor Water (gal/year)	Outdoor Water (gal/year)
General Light Industry	2,543,750	246,151
Automobile Care Center	1,317,136	6.09
Parking Lot	0.00	6.09

5.13. Operational Waste Generation**5.13.1. Unmitigated**

Land Use	Waste (ton/year)	Cogeneration (kWh/year)
General Light Industry	13.6	0.00
Automobile Care Center	53.5	0.00
Parking Lot	0.00	0.00

5.13.2. Mitigated

Land Use	Waste (ton/year)	Cogeneration (kWh/year)
General Light Industry	13.6	0.00
Automobile Care Center	53.5	0.00
Parking Lot	0.00	0.00

5.14. Operational Refrigeration and Air Conditioning Equipment

5.14.1. Unmitigated

Land Use Type	Equipment Type	Refrigerant	GWP	Quantity (kg)	Operations Leak Rate	Service Leak Rate	Times Serviced
General Light Industry	Other commercial A/C and heat pumps	R-410A	2,088	0.30	4.00	4.00	18.0
Automobile Care Center	Other commercial A/C and heat pumps	R-410A	2,088	< 0.005	4.00	4.00	18.0
Automobile Care Center	Supermarket refrigeration and condensing units	R-404A	3,922	26.5	16.5	16.5	18.0

5.14.2. Mitigated

Land Use Type	Equipment Type	Refrigerant	GWP	Quantity (kg)	Operations Leak Rate	Service Leak Rate	Times Serviced
General Light Industry	Other commercial A/C and heat pumps	R-410A	2,088	0.30	4.00	4.00	18.0
Automobile Care Center	Other commercial A/C and heat pumps	R-410A	2,088	< 0.005	4.00	4.00	18.0
Automobile Care Center	Supermarket refrigeration and condensing units	R-404A	3,922	26.5	16.5	16.5	18.0

5.15. Operational Off-Road Equipment

5.15.1. Unmitigated

Attachment 9

Equipment Type	Fuel Type	Engine Tier	Number per Day	Hours Per Day	Horsepower	Load Factor
Air Compressors	Electric	Average	10.0	8.00	37.0	0.48
—	Diesel	Average	—	8.00	—	—

5.15.2. Mitigated

Equipment Type	Fuel Type	Engine Tier	Number per Day	Hours Per Day	Horsepower	Load Factor
Air Compressors	Electric	Average	10.0	8.00	37.0	0.48
—	Diesel	Average	—	8.00	—	—

5.16. Stationary Sources

5.16.1. Emergency Generators and Fire Pumps

Equipment Type	Fuel Type	Number per Day	Hours per Day	Hours per Year	Horsepower	Load Factor
----------------	-----------	----------------	---------------	----------------	------------	-------------

5.16.2. Process Boilers

Equipment Type	Fuel Type	Number	Boiler Rating (MMBtu/hr)	Daily Heat Input (MMBtu/day)	Annual Heat Input (MMBtu/yr)
----------------	-----------	--------	--------------------------	------------------------------	------------------------------

5.17. User Defined

Equipment Type	Fuel Type
—	—

5.18. Vegetation

5.18.1. Land Use Change

5.18.1.1. Unmitigated

Attachment 9

Vegetation Land Use Type	Vegetation Soil Type	Initial Acres	Final Acres
--------------------------	----------------------	---------------	-------------

5.18.1.2. Mitigated

Vegetation Land Use Type	Vegetation Soil Type	Initial Acres	Final Acres
--------------------------	----------------------	---------------	-------------

5.18.1. Biomass Cover Type

5.18.1.1. Unmitigated

Biomass Cover Type	Initial Acres	Final Acres
--------------------	---------------	-------------

5.18.1.2. Mitigated

Biomass Cover Type	Initial Acres	Final Acres
--------------------	---------------	-------------

5.18.2. Sequestration

5.18.2.1. Unmitigated

Tree Type	Number	Electricity Saved (kWh/year)	Natural Gas Saved (btu/year)
Pistache, Chinese	35.0	—	—
Oak, interior live	-3.00	—	—
Planetree, London	-3.00	—	—

5.18.2.2. Mitigated

Tree Type	Number	Electricity Saved (kWh/year)	Natural Gas Saved (btu/year)
Pistache, Chinese	35.0	—	—
—	—	—	—
Oak, interior live	-3.00	—	—

Planetree, London	-3.00	—	—
—	—	—	—

6. Climate Risk Detailed Report

6.1. Climate Risk Summary

Cal-Adapt midcentury 2040–2059 average projections for four hazards are reported below for your project location. These are under Representation Concentration Pathway (RCP) 8.5 which assumes GHG emissions will continue to rise strongly through 2050 and then plateau around 2100.

Climate Hazard	Result for Project Location	Unit
Temperature and Extreme Heat	21.6	annual days of extreme heat
Extreme Precipitation	5.70	annual days with precipitation above 20 mm
Sea Level Rise	0.00	meters of inundation depth
Wildfire	27.4	annual hectares burned

Temperature and Extreme Heat data are for grid cell in which your project are located. The projection is based on the 98th historical percentile of daily maximum/minimum temperatures from observed historical data (32 climate model ensemble from Cal-Adapt, 2040–2059 average under RCP 8.5). Each grid cell is 6 kilometers (km) by 6 km, or 3.7 miles (mi) by 3.7 mi.

Extreme Precipitation data are for the grid cell in which your project are located. The threshold of 20 mm is equivalent to about ¾ an inch of rain, which would be light to moderate rainfall if received over a full day or heavy rain if received over a period of 2 to 4 hours. Each grid cell is 6 kilometers (km) by 6 km, or 3.7 miles (mi) by 3.7 mi.

Sea Level Rise data are for the grid cell in which your project are located. The projections are from Radke et al. (2017), as reported in Cal-Adapt (2040–2059 average under RCP 8.5), and consider different increments of sea level rise coupled with extreme storm events. Users may select from four model simulations to view the range in potential inundation depth for the grid cell. The four simulations make different assumptions about expected rainfall and temperature are: Warmer/drier (HadGEM2-ES), Cooler/wetter (CNRM-CM5), Average conditions (CanESM2), Range of different rainfall and temperature possibilities (MIROC5). Each grid cell is 50 meters (m) by 50 m, or about 164 feet (ft) by 164 ft.

Wildfire data are for the grid cell in which your project are located. The projections are from UC Davis, as reported in Cal-Adapt (2040–2059 average under RCP 8.5), and consider historical data of climate, vegetation, population density, and large (> 400 ha) fire history. Users may select from four model simulations to view the range in potential wildfire probabilities for the grid cell. The four simulations make different assumptions about expected rainfall and temperature are: Warmer/drier (HadGEM2-ES), Cooler/wetter (CNRM-CM5), Average conditions (CanESM2), Range of different rainfall and temperature possibilities (MIROC5). Each grid cell is 6 kilometers (km) by 6 km, or 3.7 miles (mi) by 3.7 mi.

6.2. Initial Climate Risk Scores

Climate Hazard	Exposure Score	Sensitivity Score	Adaptive Capacity Score	Vulnerability Score
Temperature and Extreme Heat	N/A	N/A	N/A	N/A
Extreme Precipitation	N/A	N/A	N/A	N/A
Sea Level Rise	1	0	0	N/A
Wildfire	1	0	0	N/A

Flooding	N/A	N/A	N/A	N/A
Drought	0	0	0	N/A
Snowpack	N/A	N/A	N/A	N/A
Air Quality	N/A	N/A	N/A	N/A

The sensitivity score reflects the extent to which a project would be adversely affected by exposure to a climate hazard. Exposure is rated on a scale of 1 to 5, with a score of 5 representing the greatest exposure.

The adaptive capacity of a project refers to its ability to manage and reduce vulnerabilities from projected climate hazards. Adaptive capacity is rated on a scale of 1 to 5, with a score of 5 representing the greatest ability to adapt.

The overall vulnerability scores are calculated based on the potential impacts and adaptive capacity assessments for each hazard. Scores do not include implementation of climate risk reduction measures.

6.3. Adjusted Climate Risk Scores

Climate Hazard	Exposure Score	Sensitivity Score	Adaptive Capacity Score	Vulnerability Score
Temperature and Extreme Heat	N/A	N/A	N/A	N/A
Extreme Precipitation	N/A	N/A	N/A	N/A
Sea Level Rise	1	1	1	2
Wildfire	1	1	1	2
Flooding	N/A	N/A	N/A	N/A
Drought	1	1	1	2
Snowpack	N/A	N/A	N/A	N/A
Air Quality	N/A	N/A	N/A	N/A

The sensitivity score reflects the extent to which a project would be adversely affected by exposure to a climate hazard. Exposure is rated on a scale of 1 to 5, with a score of 5 representing the greatest exposure.

The adaptive capacity of a project refers to its ability to manage and reduce vulnerabilities from projected climate hazards. Adaptive capacity is rated on a scale of 1 to 5, with a score of 5 representing the greatest ability to adapt.

The overall vulnerability scores are calculated based on the potential impacts and adaptive capacity assessments for each hazard. Scores include implementation of climate risk reduction measures.

6.4. Climate Risk Reduction Measures

6.4.1. Wildfire

User Selected Measures	Co-Benefits Achieved	Exposure Reduction	Sensitivity Reduction	Adaptive Capacity Increase
------------------------	----------------------	--------------------	-----------------------	----------------------------

WF-1: Implement Fire-safe Landscaping	Improved Air Quality, Improved Ecosystem Health, Improved Public Health	—	1.00	—
---------------------------------------	---	---	------	---

6.4.2. Drought

User Selected Measures	Co-Benefits Achieved	Exposure Reduction	Sensitivity Reduction	Adaptive Capacity Increase
D-3: Install Drought Resistant Landscaping	Water Conservation	—	1.00	1.00

7. Health and Equity Details

7.1. CalEnviroScreen 4.0 Scores

The maximum CalEnviroScreen score is 100. A high score (i.e., greater than 50) reflects a higher pollution burden compared to other census tracts in the state.

Indicator	Result for Project Census Tract
Exposure Indicators	—
AQ-Ozone	26.7
AQ-PM	4.19
AQ-DPM	7.27
Drinking Water	64.2
Lead Risk Housing	5.77
Pesticides	58.4
Toxic Releases	15.0
Traffic	35.1
Effect Indicators	—
CleanUp Sites	0.00
Groundwater	0.00
Haz Waste Facilities/Generators	16.6
Impaired Water Bodies	51.2

Solid Waste	59.2
Sensitive Population	—
Asthma	32.4
Cardio-vascular	24.0
Low Birth Weights	19.0
Socioeconomic Factor Indicators	—
Education	17.2
Housing	22.1
Linguistic	10.4
Poverty	15.8
Unemployment	6.30

7.2. Healthy Places Index Scores

The maximum Health Places Index score is 100. A high score (i.e., greater than 50) reflects healthier community conditions compared to other census tracts in the state.

Indicator	Result for Project Census Tract
Economic	—
Above Poverty	78.91697677
Employed	43.98819453
Education	—
Bachelor's or higher	70.67881432
High school enrollment	100
Preschool enrollment	76.63287566
Transportation	—
Auto Access	61.56807391
Active commuting	28.23046324
Social	—
2-parent households	63.80084691

Attachment 9

Voting	96.77916079
Neighborhood	—
Alcohol availability	75.47799307
Park access	2.194276915
Retail density	7.391248556
Supermarket access	20.78788656
Tree canopy	89.15693571
Housing	—
Homeownership	88.6179905
Housing habitability	75.08020018
Low-inc homeowner severe housing cost burden	41.46028487
Low-inc renter severe housing cost burden	37.03323495
Uncrowded housing	81.14974978
Health Outcomes	—
Insured adults	70.40934172
Arthritis	0.0
Asthma ER Admissions	59.2
High Blood Pressure	0.0
Cancer (excluding skin)	0.0
Asthma	0.0
Coronary Heart Disease	0.0
Chronic Obstructive Pulmonary Disease	0.0
Diagnosed Diabetes	0.0
Life Expectancy at Birth	62.5
Cognitively Disabled	68.5
Physically Disabled	32.1
Heart Attack ER Admissions	79.3

Attachment 9

Mental Health Not Good	0.0
Chronic Kidney Disease	0.0
Obesity	0.0
Pedestrian Injuries	19.6
Physical Health Not Good	0.0
Stroke	0.0
Health Risk Behaviors	—
Binge Drinking	0.0
Current Smoker	0.0
No Leisure Time for Physical Activity	0.0
Climate Change Exposures	—
Wildfire Risk	28.0
SLR Inundation Area	0.0
Children	84.0
Elderly	4.7
English Speaking	95.9
Foreign-born	8.4
Outdoor Workers	40.3
Climate Change Adaptive Capacity	—
Impervious Surface Cover	94.8
Traffic Density	19.7
Traffic Access	0.0
Other Indices	—
Hardship	25.9
Other Decision Support	—
2016 Voting	96.3

7.3. Overall Health & Equity Scores

Metric	Result for Project Census Tract
CalEnviroScreen 4.0 Score for Project Location (a)	6.00
Healthy Places Index Score for Project Location (b)	73.0
Project Located in a Designated Disadvantaged Community (Senate Bill 535)	No
Project Located in a Low-Income Community (Assembly Bill 1550)	No
Project Located in a Community Air Protection Program Community (Assembly Bill 617)	No

a: The maximum CalEnviroScreen score is 100. A high score (i.e., greater than 50) reflects a higher pollution burden compared to other census tracts in the state.

b: The maximum Health Places Index score is 100. A high score (i.e., greater than 50) reflects healthier community conditions compared to other census tracts in the state.

7.4. Health & Equity Measures

Measure Title	Co-Benefits Achieved
IE-5: Provide Education on Essential Topics Related to Project	Social Equity
PH-2: Increase Urban Tree Canopy and Green Spaces	Energy and Fuel Savings, Enhanced Energy Security, Improved Air Quality, Improved Ecosystem Health, Improved Public Health, Social Equity

7.5. Evaluation Scorecard

Health and Equity Evaluation Scorecard not completed.

8. User Changes to Default Data

Screen	Justification
Construction: Construction Phases	There are no existing structures to demolish
Construction: Demolition	Spreading water is required during grading.
Construction: Dust From Material Movement	Grading is balanced. No import or export trips are anticipated.

PETERBIT PASO ROBLES

2805 Theatre Drive Paso Robles, CA 93446

Attachment 9
 studio
2G
 Architects, LLP
 811 Palm Street
 San Luis Obispo, CA 93401
 www.studio2g.com
 P 805.594.0771
 F 805.594.5137
These drawings are the property of Studio 2G Architects, LLP. No part of these drawings may be reproduced or transmitted in any form or by any means, electronic, mechanical, photocopying, recording, or by any information storage and retrieval system, without the prior written permission of Studio 2G Architects, LLP.

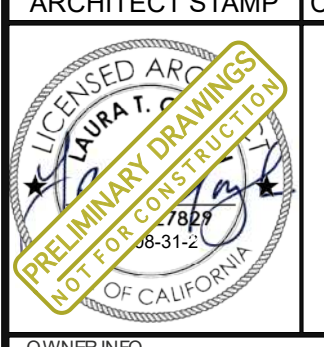
ARCHITECT STAMP

 CONSULTANT STAMP

OWNER
 Craig Archer
 3030 Ramada Drive, Paso Robles CA

CIVIL SITE PLAN
 WATER & SEWER EXTENSION PLAN
 DEMOLITION PLAN - NORTH PORTION
 DEMOLITION PLAN - SOUTH PORTION

CONCEPTUAL LANDSCAPE PLAN RENDER
 CONCEPTUAL LANDSCAPE PLAN
 PLANT IMAGERY

OVERALL ARCHITECTURAL SITE PLAN
 SITE FENCING EXHIBIT
 SITE DETAILS
 SITE LIGHTING PLAN
 SITE LIGHTING PLAN

FIRST FLOOR DIMENSIONAL PLAN
 SECOND FLOOR DIMENSIONAL PLAN
 ROOF PLAN
 EXTERIOR ELEVATIONS

TOTAL SHEETS 21

Peterbit Paso Robles
 2805 Theatre Drive
 Paso Robles, CA 93446
 APN: 009-851-022

SUBMITTALS & REVISIONS

DATE	ISSUE
03 JUN 22	DEVELOPMENT PLAN RESUBMITTAL

PERMIT HISTORY:

PERMIT	TYPE	DATE
####	PERMIT TYPE	00/00/0000

STATEMENT OF COMPLIANCE

This project has been designed in accordance with and meets the City of Paso Robles adopted code and ordinance requirements including, but not limited to the California State Accessibility Standards and I/Ws will be responsible for all clarifications deemed necessary during the construction phases.

AGENCY APPROVAL

2138

TITLE SHEET

G-001

Abbreviations

Of California	Abbreviation	Meaning
A/C	Air Conditioning	N
A.F.F.	Above Finish Floor	N.G.
ALT.	Alternate	N.I.C.
AMT.	Amount	NTS
APPROX.	Approximate	O
AVG.	Average	O
B	Board	O.C.
BD.	Board	O.D.
BTWN.	Between	OPNG.
BLDG.	Building	ORIG.
BLK / BLKG.	Block / Blocking	OZ
C	Cubic	P
C.F.M.	Cubic Feet Per Minute	PERP.
CHG.	Change	PL.
C.I.	Cast Iron	P.L.A.M.
CLR.	Clearance	P.L.Y. WD.
CLG.	Ceiling	PR.
C.M.U.	Concrete Masonry Unit	PROJ.
COL.	Column	P.S.I.
CONC.	Concrete	P.W.T.
CONSTR.	Construction	P.T.D.F.
C.O.T.G.	Clean Out To Grade	Q
CTR.	Center	QTY
CU. FT.	Cubic Foot	R
CU. IN.	Cubic Inch	R
CU. YD.	Cubic Yard	R.
D	Double	RD.
DEG.	Degree	REF.
DEPT.	Department	REIN.
DIAG.	Diagonal	REQ.
DIA.	Diameter	RM.
DM.	Dimension	R.O.
DIV.	Division	R.T.S.
D.S.	Downspout	S
D.W.	Downspout / Downspout	SCHED.
E	Existing	S.C.
EG	Each	SECT.
EA	Each	SHWR.
ELEC.	Electric	SHT.
ELEV.	Elevation / Elevator	SIM.
ENCL.	Enclosure	SPEC(S).
EQ.	Equal	SQ.
EQUIP.	Equipment	SQ. FT.
EXIST.	Existing	S.S.
EXT.	Exterior	ST.
F	Floor	STD.
F.D.	Floor Drain	STL.
F.G.	Finish Grade	STOR.
F.H.	Fire Hydrant	STRUCT.
FIN.	Finish	SYST.
FLR.	Floor	T
FLUOR.	Fluorescent	T
F.O.C.	Face Of Concrete	T.O.C.
F.O.F.	Face Of Finish	T.O.C.B.
F.O.M.	Face Of Masonry	TEL.
F.O.S.	Face Of Stud	TEMO.
FS.	Finish Surface	TKG
FT.	Foot	TH.
FTG.	Footing	TOL.
G	Gauge	T.O.P.
GA.	Gallon	T.O.S.
GAL.	Gallon	T.O.W.
GALV.	Galvanized	TV
GYP.	Gypsum	TYP.
H	Hose Bibb	UNFIN.
HDR.	Header	UN D.
HRDW.	Hardware	UNLESS NOTED OTHERWISE
HORIZ.	Horizontal	U
HP	Hot Pipe Power	V
HT.	Height	V.C.T.
I.D.	Inside Diameter	VENT.
IN.	Inch	VERT.
INFO.	Information	V.T.R.
INSUL.	Insulation	W
INT.	Interior	W.C.
J	Janitor	WD.
JAN.	Janitor	W.H.
JCT.	Junction	W.I.
JT	Joint	W.R.B.
K	Kitchen	WOM.
KIT.	Kitchen	W.P.
L	Lavatory	W.SCT.
LAV.	Lavatory	W/
LB.	Pound	W/O
L.F.	Lineal Foot	
LN.	Linear	
LT.	Light	
LTWT.	Light Weight	
M	Maximum	
MAX.	Maximum	
M.B.	Machine Bolt	
M.C.	Mechanical Cabinet	
MECH.	Mechanical	
MED.	Medium	
MEZZ.	Mezzanine	
MFR. / MFG.	Manufacturer	
MIN.	Minimum	
MISC.	Miscellaneous	
MTL.	Metal	

Symbols Legend

	Indicates Direction Of View		Door ID - Refer To Sheet A3.0
	Section Cut Reference Sheet Number		Window ID - Refer To Sheet A3.1
	Indicates Direction Of View		EXIT - Exit Sign Refer To Life Safety Plans and 'E' sheets for locations and requirements.
	Interior Elevation Reference Number Sheet Number		

- ### BUILDING MAINTENANCE AND OPERATION
- At the time of final inspection, a manual, compact disc, web-based reference or other media acceptable to the enforcing agency, which includes all of the following shall be placed in the building:
 - Directions to the owner or occupant that the manual shall remain with the building throughout the life cycle of the structure.
 - Operation and maintenance instructions for the following:
 - Equipment and appliances, including water-saving devices and systems, HVAC systems, water-heating systems and other major appliances and equipment.
 - Roof and yard drainage, including gutters and downspouts.
 - Space conditioning systems, including condensers and air filters.
 - Landscape irrigation systems.
 - Water reuse systems.
 - Information from local utility, water and waste recovery providers on methods to further reduce resource consumption, including recycle programs and locations.
 - Public transportation and/or carpool options available in the area.
 - Educational material on the positive impacts of an interior relative humidity between 30-60% and what methods an occupant may use to maintain the relative humidity level in that range.
 - Information about water-conserving landscape and irrigation design and controllers which conserve water.
 - Instructions for maintaining gutters and downspouts and the importance of diverting water at least 5' away from the foundation.
 - Information on required routine maintenance measures, including, but not limited to, caulking, painting, grading around the building, etc.
 - Information about state solar energy and incentive programs available.
 - A copy of all special inspection verifications required by the enforcing agency or this code.

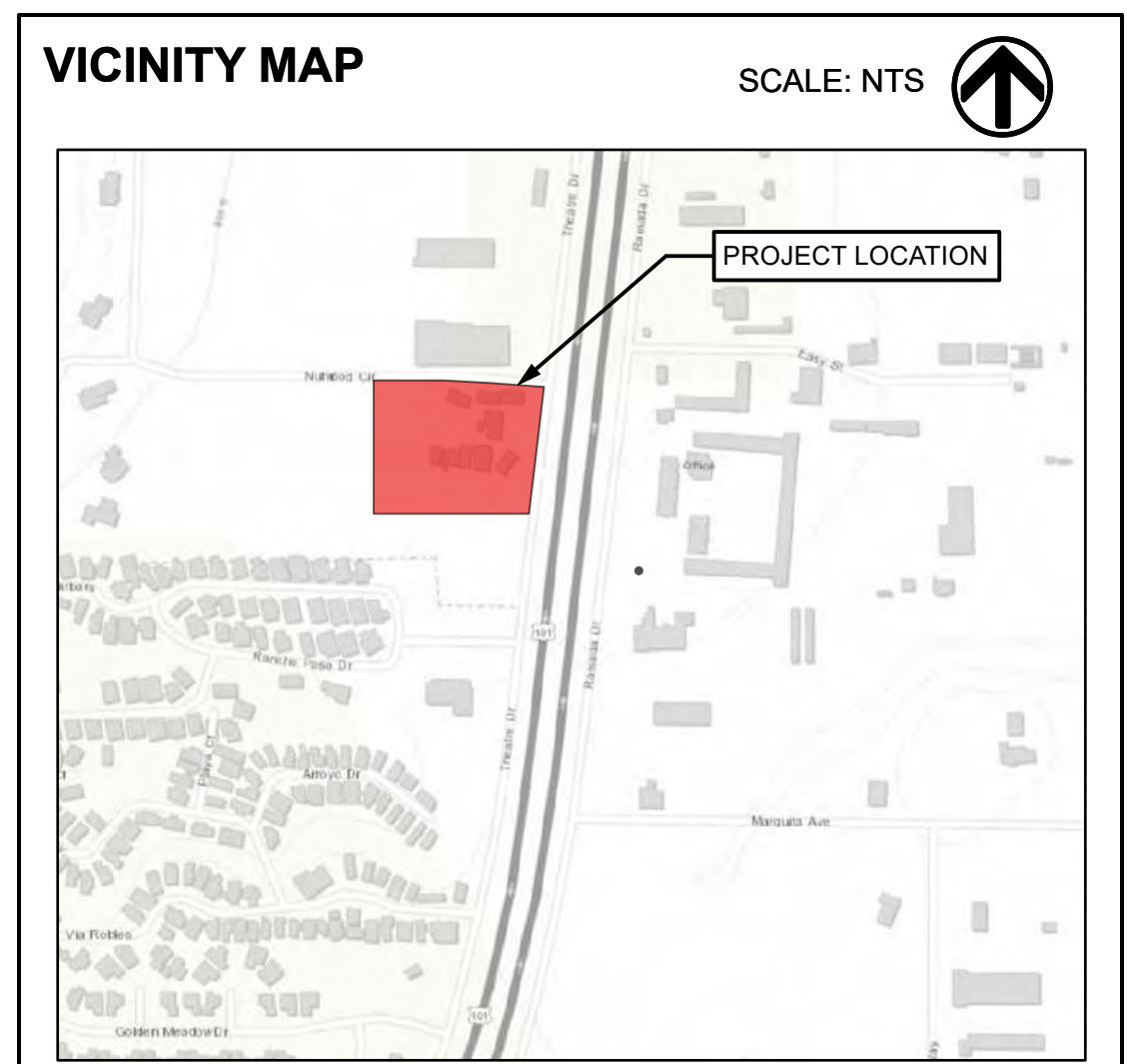

- ### PROJECT REQUIREMENT - CITY OF PASO ROBLES
- COMMERCIAL CITY OF PASO ROBLES

This project shall comply with the 2019 California Building Code (CBC).

Codes: All construction shall conform to the following codes:
 - 2019 California Building Code Vol. 1 & 2 (2018 IBC)
 - 2019 California Electrical Code (2017 NEC)
 - 2019 California Mechanical Code (2018 UMC)
 - 2019 California Plumbing Code (2018 UPC)
 - 2019 California Energy Code
 - 2019 California Fire Code (2018 IFC)
 - 2019 Green Building Standards Code (CALGREEN Code)
 - City of Paso Robles Building and Construction Ordinance Title 17
 - City of Paso Robles Fire Code Ordinance Title 16
 - City of Paso Robles Zoning Ordinance Title 21

NFPA - National Fire Codes, all other codes and ordinances adopted by the agencies having jurisdiction over this project.

All Amendments to the CA Codes adopted by the City of Paso Robles, and all other codes, regulations, and approvals established by the City of Paso Robles.

All work located within the public right of way or within the jurisdiction of the City Utilities and Public Works Departments shall comply with the most current edition of the engineering standards and standards specifications.

- ### CONSTRUCTION WASTE MANAGEMENT PLAN
- Contractor shall submit a construction waste management plan in conformance with items 1 through 5. The construction waste management plan shall be updated as necessary and shall be available during construction for examination by the enforcing agency.
 - Identify the construction and demolition waste materials to be diverted from disposal by recycling, reuse on the project or salvage for future use or sale.
 - Specify if construction and demolition waste materials will be sorted on-site (source-separated) or bulk mixed (single stream).
 - Identify diversion facilities where the construction and demolition waste material will be taken.
 - Identify construction methods employed to reduce the amount of construction and demolition waste generated.
 - Specify that the amount of construction and demolition waste materials diverted shall be calculated by weight or volume, but not by both.
- A minimum of 75% of the construction waste generated at the site is diverted to recycle or salvage per Title 17 City of Paso Robles Ordinance.*

SPECIAL INSPECTIONS

X

SCHEDULE OF CHANGES

X

- ### SEPERATE PERMIT
- NFPA 13 Sprinkler System, Deferred Submittal
 - FD Underground Fire Line Permit, Deferred Submittal
 - Fire Alarm Permit, Deferred Submittal
 - PRFS permit for gates across a fire lane.

PROJECT TEAM

OWNER / CLIENT Coast Counties Peterbilt CONTACT: Craig Archer 3030 Ramada Drive Paso Robles, CA 93446	ARCHITECT Studio 2G Architects, LLP Laura Gough, AIA 811 Palm St. San Luis Obispo, CA 93401 P: 805.594.0771 EXT.112 F: 805.540.5137	CIVIL ENGINEER Tartaglia Engineering Robert Tartaglia 7360 El Camino Real #E Atascadero, CA 93422 P: 805.466.5660
PLANNER Planning Solutions Pam Jardini 1360 New Wine Place Templeton, CA 93465 P: 805.801.0453	MECHANICAL / PLUMBING EMA Mechanical CONTACT: Dustin Lane 689 Tank Farm Rd, Ste. 240 San Luis Obispo, CA 93401 P: 805.544.4269	ELECTRICAL JMPE Electrical Engineering CONTACT: John Maloney 627 Olive Street Santa Barbara, CA 93101 P: 805.569.8216
LANDSCAPE ARCHITECT Plein Air Design Group CONTACT: Kevin Small 3203 Lightning St., Ste.201 Santa Maria, CA 93455 P: 805.349.9695	CONTRACTOR Wiemann G Construction Greg Wiemann 3400 Stage Springs Rd. Creston, CA 93432 P: 805.674.0125	

PROJECT INFO

PROJECT DESCRIPTION

Semi truck service, parts retailer, and sales dealership. There shall be offices and operations for employees, lounge area for customers and repair shop for trucks. The site will have inventory and customer parking areas and circulation for semi trucks.

SCOPE OF WORK

Grading and drainage control for proposal retailer facility with fatwork and landscaping to support building use. Construction of an 25,000+ SF, two story building to accommodate the proposed uses. Site lighting and signage as required.

SITE SUMMARY

ADDRESS:	2805 Theatre Drive
APN:	009-851-022
PARCEL SIZE:	6.8 acres
FIRE SEVERITY ZONE:	N/A

BUILDING SUMMARY

USE:	C2
OCCUPANCY:	H-2 / M
CONSTRUCTION TYPE:	I/A
EXISTING STORIES:	N/A
PROPOSED STORIES:	2

BUILDING AREA

NEW CONDITIONED GROUND FLOOR RETAIL/SERVICE SECOND FLOOR BOHPARTS	20,735 SF 4,553 SF
TOTAL (N) CONDITIONED	25,288 SF
NEW UNCONDITIONED DIESEL SERVICE AREA OUTDOOR COVERED AREA	1,889 SF 3,330 SF
TOTAL (N) UNCONDITIONED	5,219 SF
TOTAL EXISTING	0 SF
TOTAL NEW	30,507 SF
TOTAL PROJECT SIZE	30,507 SF

AGENCIES & UTILITIES - CITY OF PASO ROBLES

BUILDING DEPARTMENT 1000 Spring Street Paso Robles, CA 93446 805.237.3850	POLICE DEPARTMENT 900 Park Street Paso Robles, CA 93446 805.237.6464	SBC / ATAT Service Center 800.310.2355 (Residential) 800.750.2355 (Business)
PLANNING DEPARTMENT 1000 Spring Street Paso Robles, CA 93446 805.237.3970	FIRE DEPARTMENT 800 Park Street Paso Robles, CA 93446 805.227.7560	PG & E 400 Higuera Street San Luis Obispo, CA 93401 805.546.5380
PUBLIC WORKS DEPARTMENT 821 Pine Street #A Paso Robles, CA 93446 805.737.3996	UTILITIES DEPARTMENT 879 Morro Street San Luis Obispo, CA 93401 805.781.7237	SOCALGAS 2240 Emily Street San Luis Obispo, CA 93401 800.427.2200

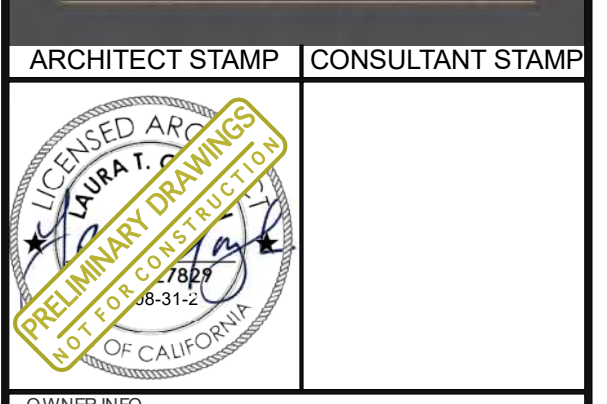

OWNER INFO
Craig Archer
 3030 Ramada Drive, Paso Robles CA

Peterbilt Paso Robles
 2805 Theatre Drive
 Paso Robles, CA 93446
 APN: 009-851-022

DATE: 03 JUN 22
 ISSUE: DEVELOPMENT PLAN RESUBMITTAL

JOHN NUMBER: 2138

SOILS REPORT

G-022

HALLIN GEOTECHNICAL, Inc.
LOG OF BORING

Site Location: Paso Robles, CA Theatre Drive; APN: 009-851-022 Project No. H-211472
 Driller/Helper: DH/MW
 Rig Type: Giddings
 Auger Diameter: 6"
 Date: January 26, 2022

BORING NO. 3

Depth (ft.)	Bag	Blows	Drilling	Comments/Voids	Moisture	Description	USCS	Soil ID
0					Moist	Orange brown slightly silty medium to coarse sands	SM	A1
						Dark brown silty sandy clay	CL	C1
5								
10								
15								
20								
25								
30								
35								
40								

GROUNDWATER Time: Depth: N.E.

SAMPLE TYPE: U=Undisturbed ring sample, S=Standard penetration tube, T= Shelby tube. [] 3" [] Other:

HALLIN GEOTECHNICAL, Inc.
LOG OF BORING

Site Location: Paso Robles, CA Theatre Drive; APN: 009-851-022 Project No. H-211472
 Driller/Helper: DH/MW
 Rig Type: Giddings
 Auger Diameter: 6"
 Date: January 26, 2022

BORING NO. 4

Depth (ft.)	Bag	Blows	Drilling	Comments/Voids	Moisture	Description	USCS	Soil ID
0					Moist	Orange brown slightly silty medium to coarse sands	SM	A1
						Dark brown silty sandy clay	CL	C1
5								
10								
15								
20								
25								
30								
35								
40								

GROUNDWATER Time: Depth: N.E.

SAMPLE TYPE: U=Undisturbed ring sample, S=Standard penetration tube, T= Shelby tube. [] 3" [] Other:

APPENDIX B
 Laboratory Testing
 Test Results
 Bench & Keyway Detail
 Transition Lot Detail

HALLIN GEOTECHNICAL, Inc.
LOG OF BORING

Site Location: Paso Robles, CA Theatre Drive; APN: 009-851-022 Project No. H-211472
 Driller/Helper: DH/MW
 Rig Type: Giddings
 Auger Diameter: 6"
 Date: January 26, 2022

BORING NO. 1

Depth (ft.)	Bag	Blows	Drilling	Comments/Voids	Moisture	Description	USCS	Soil ID
0					Moist	Orange brown slightly silty medium to coarse sands	SM	A1
						Dark brown silty sandy clay	CL	C1
5								
10								
15								
20								
25								
30								
35								
40								

GROUNDWATER Time: Depth: N.E.

SAMPLE TYPE: U=Undisturbed ring sample, S=Standard penetration tube, T= Shelby tube. [] 3" [] Other:

HALLIN GEOTECHNICAL, Inc.
LOG OF BORING

Site Location: Paso Robles, CA Theatre Drive; APN: 009-851-022 Project No. H-211472
 Driller/Helper: DH/MW
 Rig Type: Giddings
 Auger Diameter: 6"
 Date: January 26, 2022

BORING NO. 2

Depth (ft.)	Bag	Blows	Drilling	Comments/Voids	Moisture	Description	USCS	Soil ID
0					Moist	Orange brown slightly silty medium to coarse sands	SM	A1
						Dark brown silty sandy clay	CL	C1
5								
10								
15								
20								
25								
30								
35								
40								

GROUNDWATER Time: Depth: N.E.

SAMPLE TYPE: U=Undisturbed ring sample, S=Standard penetration tube, T= Shelby tube. [] 3" [] Other:

B-1
LABORATORY TESTING

Samples were reviewed along with field logs to determine which would be analyzed further. Those chosen for laboratory analysis were considered representative of soils that would be exposed and/or used during grading, and those deemed to be within the influence of the proposed structure. Test results are presented in this Appendix.

In-situ Moisture Content and Unit Dry Weight for the ring samples were determined in general accordance with ASTM D 2947.

Expansion index test were performed on bulk soil samples in accordance with the ASTM Test Method. The samples were surcharged under 144 pounds per square foot at moisture content of near 50% saturation. Samples were then submerged in water for 24 hours and the amount of expansion was recorded with a dial indicator.

Maximum density was performed to estimate the moisture-density relationship of typical soil materials. The tests were performed in accordance with ASTM designation D 1557-88.

HALLIN GEOTECHNICAL, Inc.
LOG OF BORING

Site Location: Paso Robles, CA Theatre Drive; APN: 009-851-022 Project No. H-211472
 Driller/Helper: DH/MW
 Rig Type: Giddings
 Auger Diameter: 6"
 Date: January 26, 2022

BORING NO. 2

Depth (ft.)	Bag	Blows	Drilling	Comments/Voids	Moisture	Description	USCS	Soil ID
0					Moist	Orange brown slightly silty medium to coarse sands	SM	A1
						Dark brown silty sandy clay	CL	C1
5								
10								
15								
20								
25								
30								
35								
40								

GROUNDWATER Time: Depth: N.E.

SAMPLE TYPE: U=Undisturbed ring sample, S=Standard penetration tube, T= Shelby tube. [] 3" [] Other:

MAJOR DIVISIONS	GRAIN SYMBOL	LETTER SYMBOL	TYPICAL DESCRIPTIONS
COARSE GRAINED SOILS	GRAVEL AND GRAVELLY SOILS	GW	WELL-SORTED GRAVEL, SAND, SILT AND CLAY
		GM	MODERATELY SORTED GRAVEL, SAND, SILT AND CLAY
		GC	POORLY SORTED GRAVEL, SAND, SILT AND CLAY
		GP	POORLY SORTED GRAVEL, SAND, SILT AND CLAY WITH HIGH FRACTION RETAINED ON NO. 40 SIEVE
FINE GRAINED SOILS	SAND AND SANDY SOILS	SW	WELL-SORTED SAND, SILT AND CLAY
		SM	MODERATELY SORTED SAND, SILT AND CLAY
		SC	POORLY SORTED SAND, SILT AND CLAY
		SP	POORLY SORTED SAND, SILT AND CLAY WITH HIGH FRACTION RETAINED ON NO. 40 SIEVE
NEARLY ORGANIC SOILS	SILTS AND CLAYS	ML	LOW PLASTICITY SILT AND CLAY
		OL	LOW PLASTICITY SILT AND CLAY WITH HIGH ORGANIC CONTENT
		MH	MEDIUM PLASTICITY SILT AND CLAY
		OH	MEDIUM PLASTICITY SILT AND CLAY WITH HIGH ORGANIC CONTENT

B-2
TEST RESULTS

Boring Depth	1@0'-1'	1@1'-6"	1@6'-12"	1@12'-20"
Soil Type	A1	C1	A2	A3
USCS	SM	SM/CL	SM	SM/SC
Maximum Density (pcf)	126.4	116.0	121.7	119.6
Optimum Moisture (%)	10.6	14.2	11.0	12.1
Expansion Index	0	73	0	52

SIDEWALK NOTE:
 NEW SIDEWALK SHALL BE CONSTRUCTED ADJACENT TO THE EXISTING CURB AND GUTTER IN NUTWOOD CIRCLE FROM THE CURB RETURN ON THEATRE DRIVE TO THE WEST PROPERTY LINE AS SHOWN.

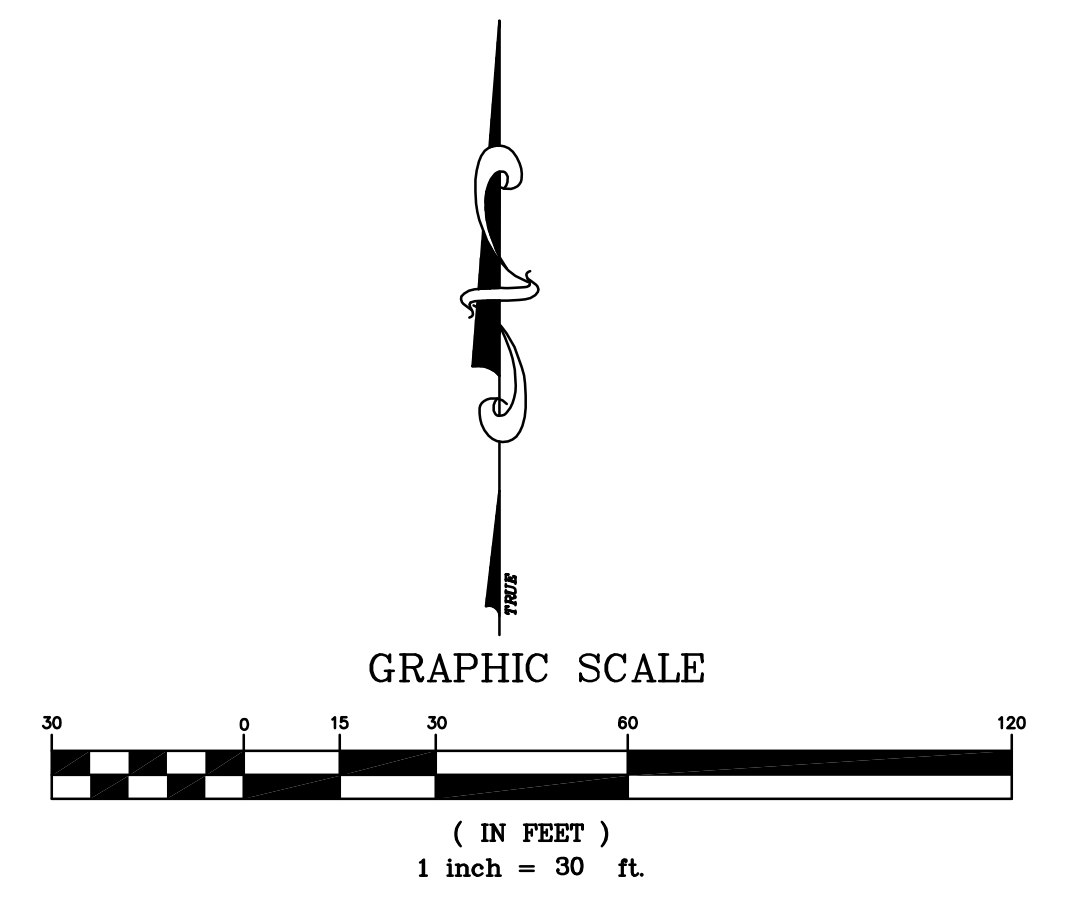
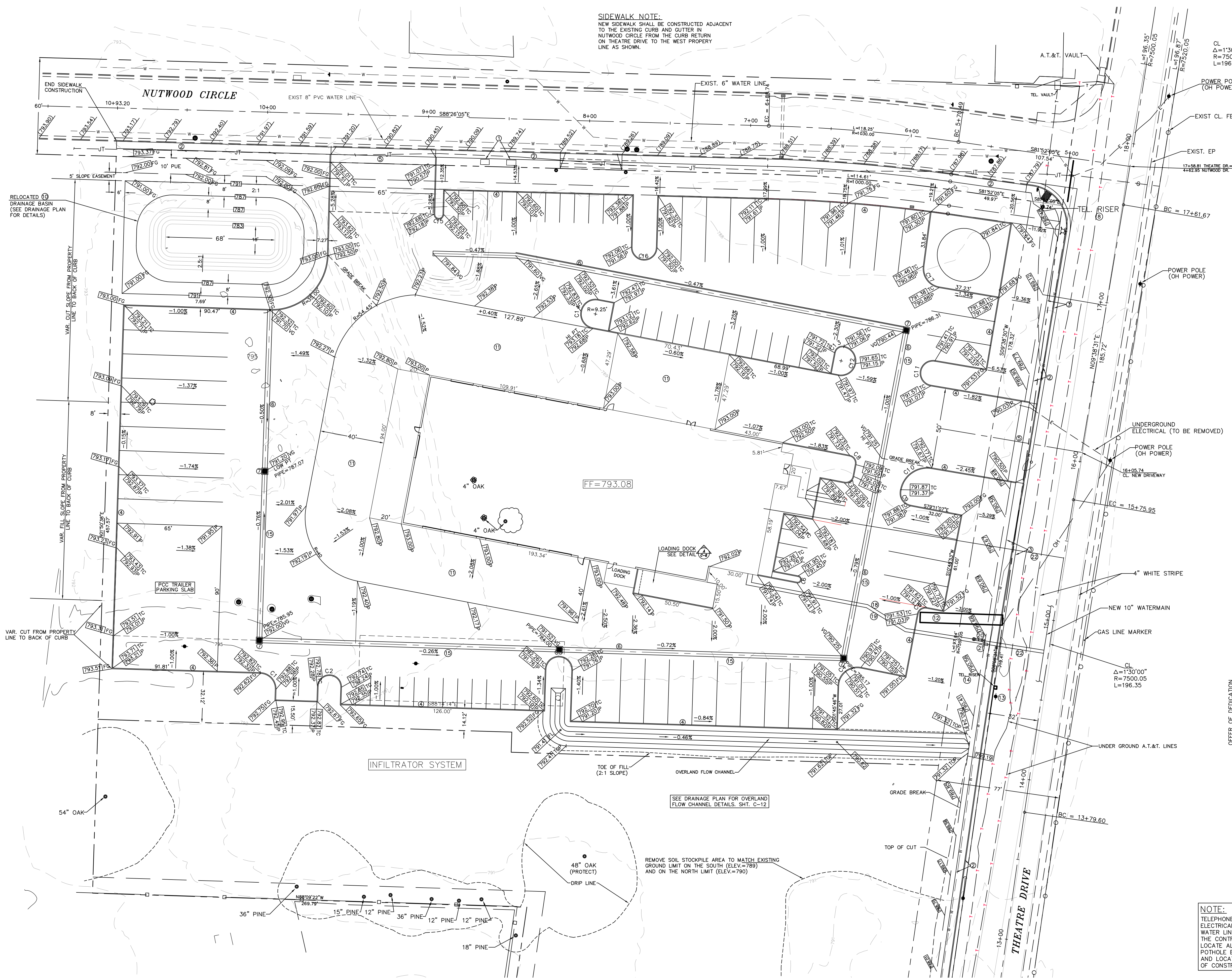

CONSTRUCTION NOTES LEGEND

- ① ADJUST UTILITY VAULTS TO FINISH GRADE
- ② CONSTRUCT SIDEWALK PER PASO ROBLES CITY STD. C-3 (5' TO FACE OF CURB)
- ③ CONSTRUCT CURB, GUTTER AND SIDEWALK PER PASO ROBLES CITY ST. C-1 & C-3
- ④ CONSTRUCT CURB ONLY PER SAN LUIS OBISPO COUNTY STD. C-3
- ⑤ CONSTRUCT COMMERCIAL DRIVE APPROACH PER CITY OF PASO ROBLES STD. C-9 CONCRETE TO BE 8" THICK.
- ⑥ CONSTRUCT PCC VALLEY GUTTER PER DETAIL 15
- ⑦ CONSTRUCT 24"x24" DRAIN INLET WITH TRAFFIC RATED GRATE AS MANUFACTURED BY MID STATE CONCRETE PRODUCTS OR APPROVED EQUAL
- ⑧ TELEPHONE PEDESTAL TO BE RELOCATED BY A.T.&T.
- ⑨ EXISTING 18" HDPE TO BE EXTENDED TO NEW POND LOCATION
- ⑩ CONSTRUCT RELOCATED POND TO THE DIMENSIONS AS SHOWN WITH 2.5:1 SIDE SLOPES (SEE STORM DRAINAGE PLAN FOR DETAILS)
- ⑪ CONSTRUCT CONCRETE APRON PER DETAILS ON PLAN SHT. 16
- ⑫ BILLBOARD TO REMAIN.
- ⑬ SERVICE POLE TO BE REMOVED
- ⑭ TELEPHONE RISER TO BE ADJUSTED BY TELEPHONE CO.
- ⑮ INSTALL 10" HDPE STORM DRAIN UNDER VALLEY GUTTER
- ⑯ INSTALL STORM DRAIN MANHOLE PER CITY STD. D-2
- ⑰ INSTALL STORM DRAIN MANHOLE PER CITY STD. D-2 WITH GRATED LID.
- ⑱ 4" FIRE SERVICE LINE
- ⑲ 2" WATER SERVICE LATERAL
- ⑳ 4" FIRE SERVICE LINE INSTALLATION, CITY STD. G-16.
- ㉑ 2" WATER METER & BOX, CITY STD. G-3.
- ㉒ "POT HOLE" EXISTING UTILITY TO VERIFY DEPTH & LOCATION.

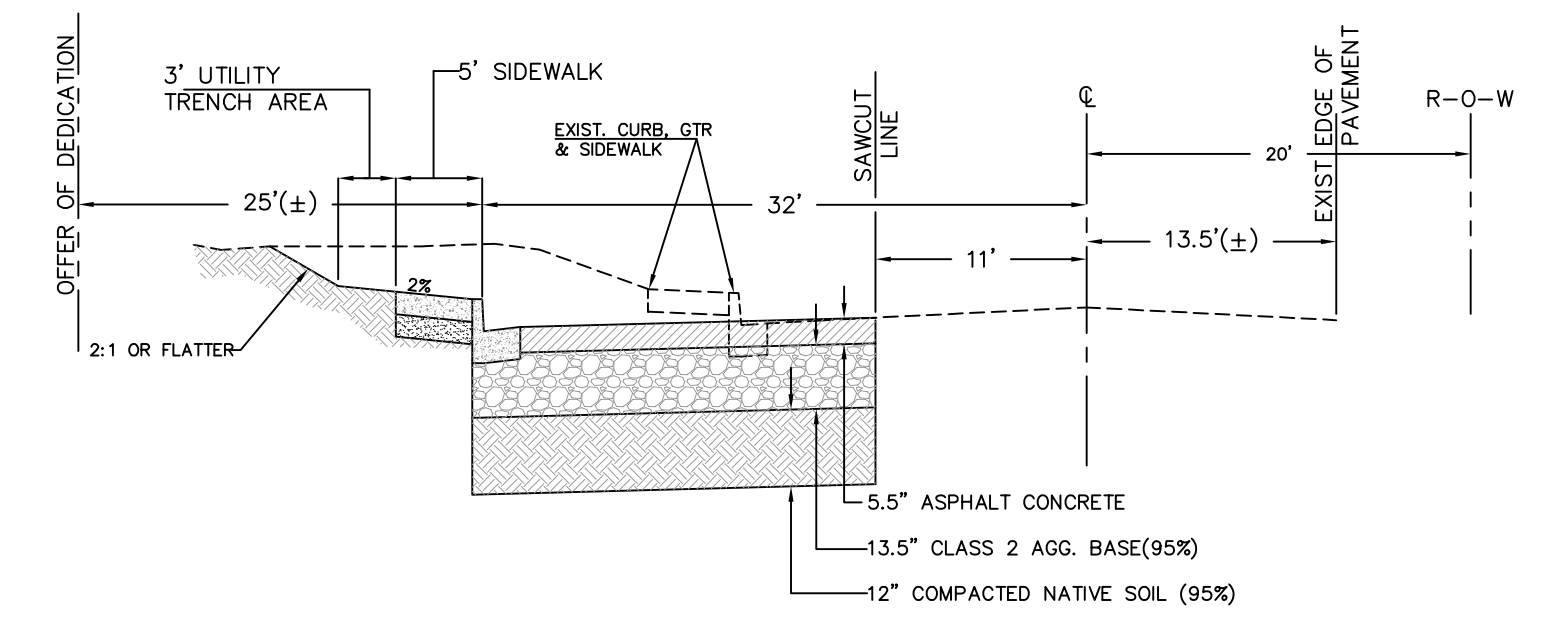

NOTE:
 TELEPHONE LINES, GAS MAIN AND SERVICES, ELECTRICAL LINES, A.T.&T. LINES AND PRIVATE WATER LINES EXIST IN THE AREA OF WORK. THE CONTRACTOR SHALL CALL USA TO FIELD LOCATE ALL FACILITIES AND HE SHALL THEN POTHOLE EACH UTILITY TO VERIFY DEPTH AND LOCATION PRIOR TO THE START OF CONSTRUCTION.

SEE PLAN SHT. C-5 FOR CURVE TABLE

UNDERGROUND SERVICE ALERT
 DIAL 811
 TWO WORKING DAYS BEFORE YOU DIG

PETERBILT - SITE PLAN (NORTH)
 2805 THEATRE DRIVE

REV.	DESCRIPTION	DATE	APP.
1			
2			
3			
4			
5			
6			
7			
8			
9			
10			

TARTAGLIA ENGINEERING
 CIVIL ENGINEERS
 7360 El Camino Real, Suite E, Atascadero, CA 93422
 805-466-5660 FAX: 805-466-5471

C. ARCHER



DESIGN	RCT
DRAWN	RCT
CHECKED	XXX
SCALE	1"=30'
DWG. NO.	21-19
DATE	4/01/22
SHEET	C-4 of 18

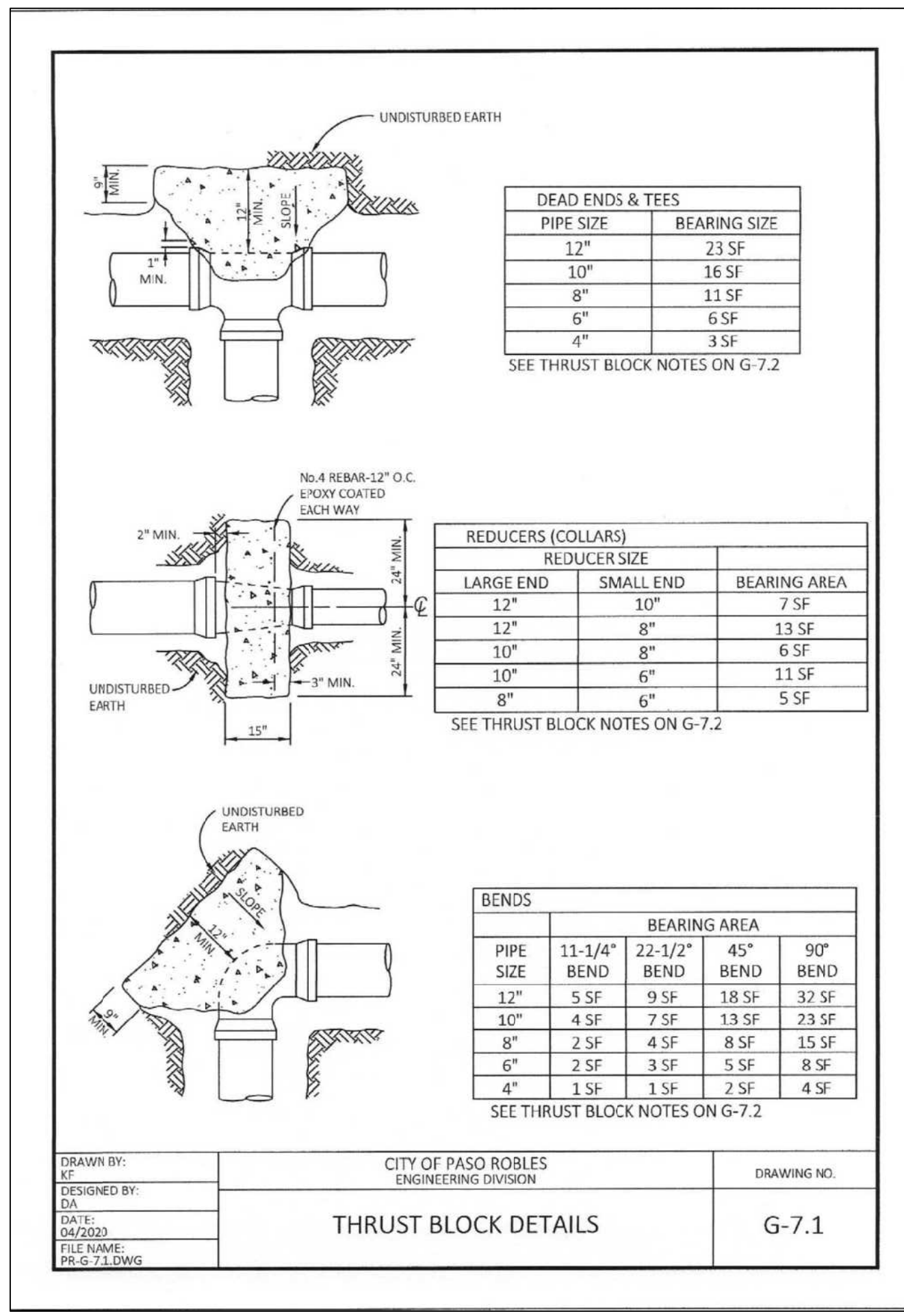

DEAD ENDS & TEES

PIPE SIZE	BEARING SIZE
12"	23 SF
10"	16 SF
8"	11 SF
6"	6 SF
4"	3 SF

SEE THRUST BLOCK NOTES ON G-7.2

REDUCERS (COLLARS)

LARGE END	SMALL END	BEARING AREA
12"	10"	7 SF
12"	8"	13 SF
10"	8"	6 SF
10"	6"	11 SF
8"	6"	5 SF

SEE THRUST BLOCK NOTES ON G-7.2

BENDS

PIPE SIZE	11-1/4" BEND	22-1/2" BEND	45" BEND	90" BEND
12"	5 SF	9 SF	18 SF	32 SF
10"	4 SF	7 SF	13 SF	23 SF
8"	2 SF	4 SF	8 SF	15 SF
6"	2 SF	3 SF	5 SF	8 SF
4"	1 SF	1 SF	2 SF	4 SF

SEE THRUST BLOCK NOTES ON G-7.2

DRAWN BY: KF
DESIGNED BY: DA
DATE: 04/20/20
FILE NAME: PR-G-7.1.DWG

CITY OF PASO ROBLES ENGINEERING DIVISION

THRUST BLOCK DETAILS

DRAWING NO. G-7.1

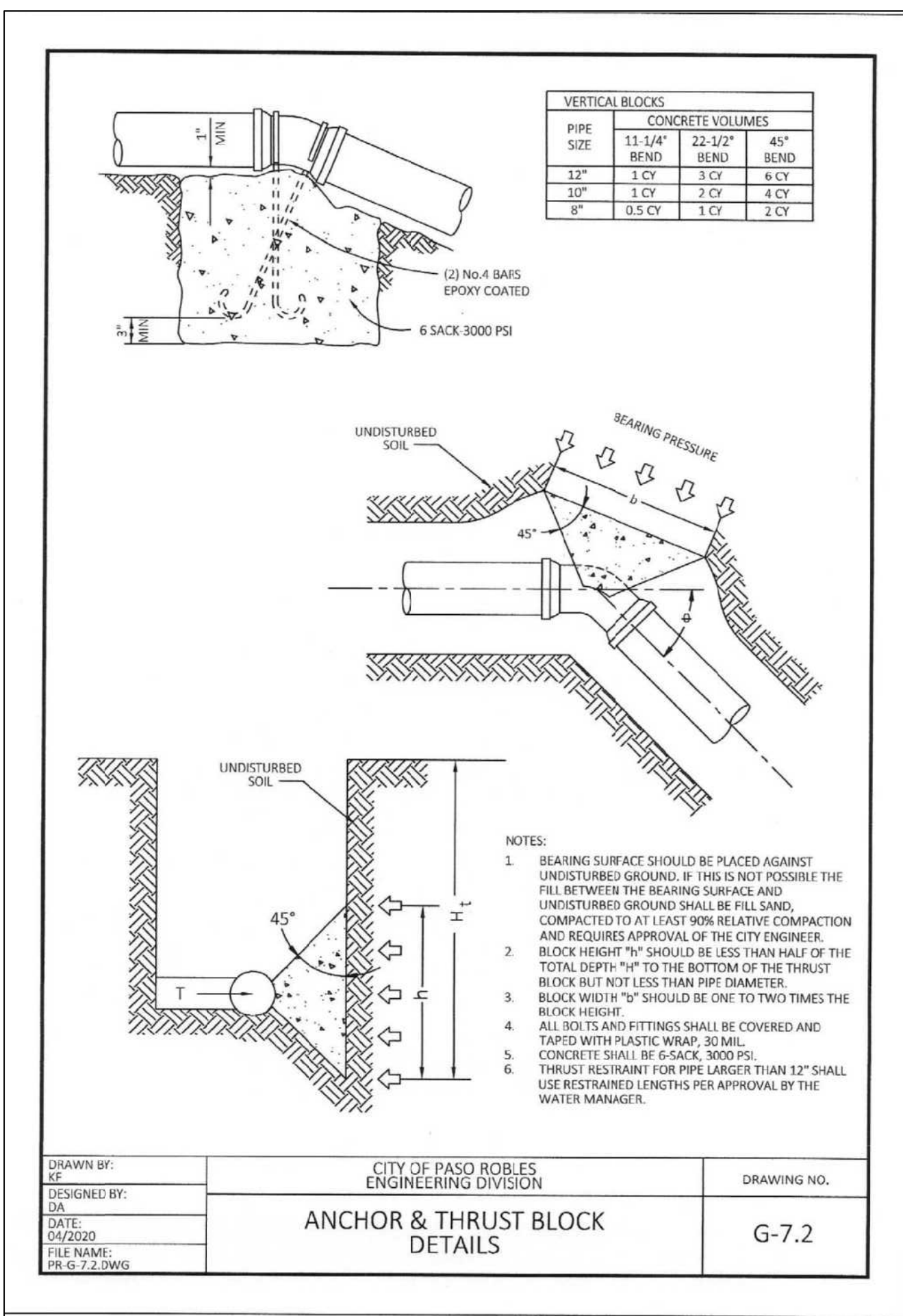

VERTICAL BLOCKS

PIPE SIZE	CONCRETE VOLUMES	
11-1/4" BEND	22-1/2" BEND	45" BEND
1.1 CY	3 CY	6 CY
10" 1.3 CY	2 CY	4 CY
8" 0.5 CY	1 CY	2 CY

6 SACK 3000 PSI

NOTES:

- BEARING SURFACE SHOULD BE PLACED AGAINST UNDISTURBED GROUND. IF THIS IS NOT POSSIBLE THE FILL BETWEEN THE BEARING SURFACE AND UNDISTURBED GROUND SHALL BE FILL SAND, COMPACTED TO AT LEAST 90% RELATIVE COMPACTION AND REQUIRES APPROVAL OF THE CITY ENGINEER.
- BLOCK HEIGHT "H" SHOULD BE LESS THAN HALF OF THE TOTAL DEPTH "T" TO THE BOTTOM OF THE THRUST BLOCK BUT NOT LESS THAN PIPE DIAMETER.
- BLOCK WIDTH "W" SHOULD BE ONE TO TWO TIMES THE BLOCK HEIGHT.
- ALL BOLTS AND FITTINGS SHALL BE COVERED AND TAPPED WITH PLASTIC WRAP 30 MIL.
- CONCRETE SHALL BE 6-SACK, 3000 PSI.
- THRUST RESTRAINT FOR PIPE LARGER THAN 12" SHALL USE RESTRAINED LENGTHS PER APPROVAL BY THE WATER MANAGER.

DRAWN BY: KF
DESIGNED BY: DA
DATE: 04/20/20
FILE NAME: PR-G-7.2.DWG

CITY OF PASO ROBLES ENGINEERING DIVISION

ANCHOR & THRUST BLOCK DETAILS

DRAWING NO. G-7.2

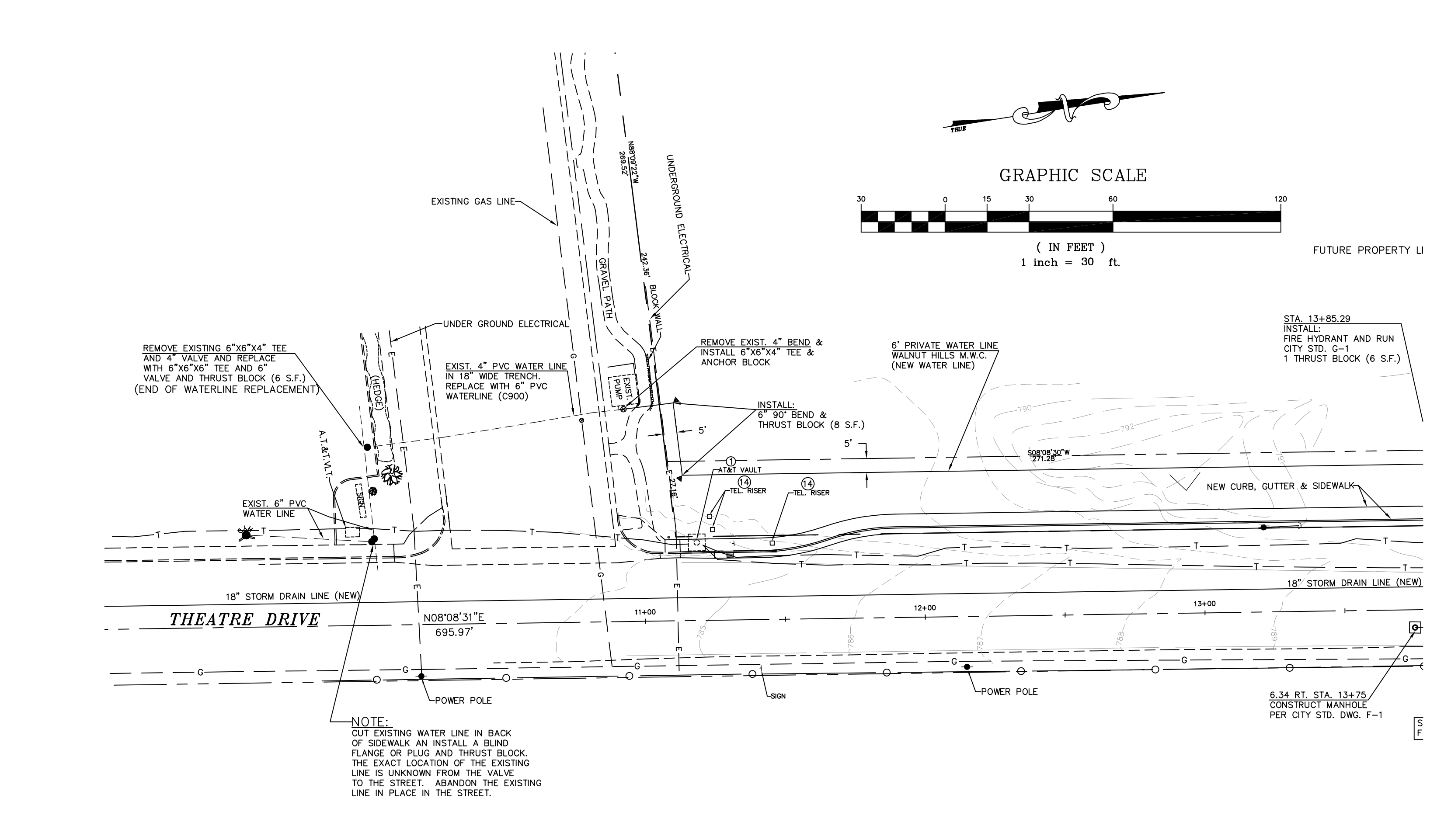

EXISTING GAS LINE
UNDER GROUND ELECTRICAL
EXISTING 4" PVC WATER LINE IN 18" WIDE TRENCH. REPLACE WITH 6" PVC WATERLINE (C900)
REMOVE EXIST. 4" BEND & INSTALL 6" X 6" X 4" TEE & ANCHOR BLOCK
6" PRIVATE WATER LINE WALNUT HILLS M.W.C. (NEW WATER LINE)
INSTALL: 6" 90° BEND & THRUST BLOCK (6 S.F.)
A.T. & T. VALVE
TEL. RISER
NEW CURB, GUTTER & SIDEWALK
18" STORM DRAIN LINE (NEW)
18" STORM DRAIN LINE (NEW)
POWER POLE
POWER POLE
THEATRE DRIVE
N08°08'31"E
695.97
11+00
12+00
13+00
STA. 13+85.29
INSTALL: FIRE HYDRANT AND RUN CITY STD. G-1 1 THRUST BLOCK (6 S.F.)
6.34 FT. STA. 13+75 CONSTRUCT MANHOLE PER CITY STD. DWG. F-1

NOTE: CUT EXISTING WATER LINE IN BACK OF SIDEWALK AND INSTALL A BLIND FLANGE OR PLUG AND THRUST BLOCK. THE EXACT LOCATION OF THE EXISTING LINE IS UNKNOWN FROM THE VALVE TO THE STREET. ABANDON THE EXISTING LINE IN PLACE IN THE STREET.

DRAWN BY: KF
DESIGNED BY: DA
DATE: 04/20/20
FILE NAME: PR-G-7.2.DWG

CITY OF PASO ROBLES ENGINEERING DIVISION

GRAPHIC SCALE
(IN FEET)
1 inch = 30 ft.

FUTURE PROPERTY L

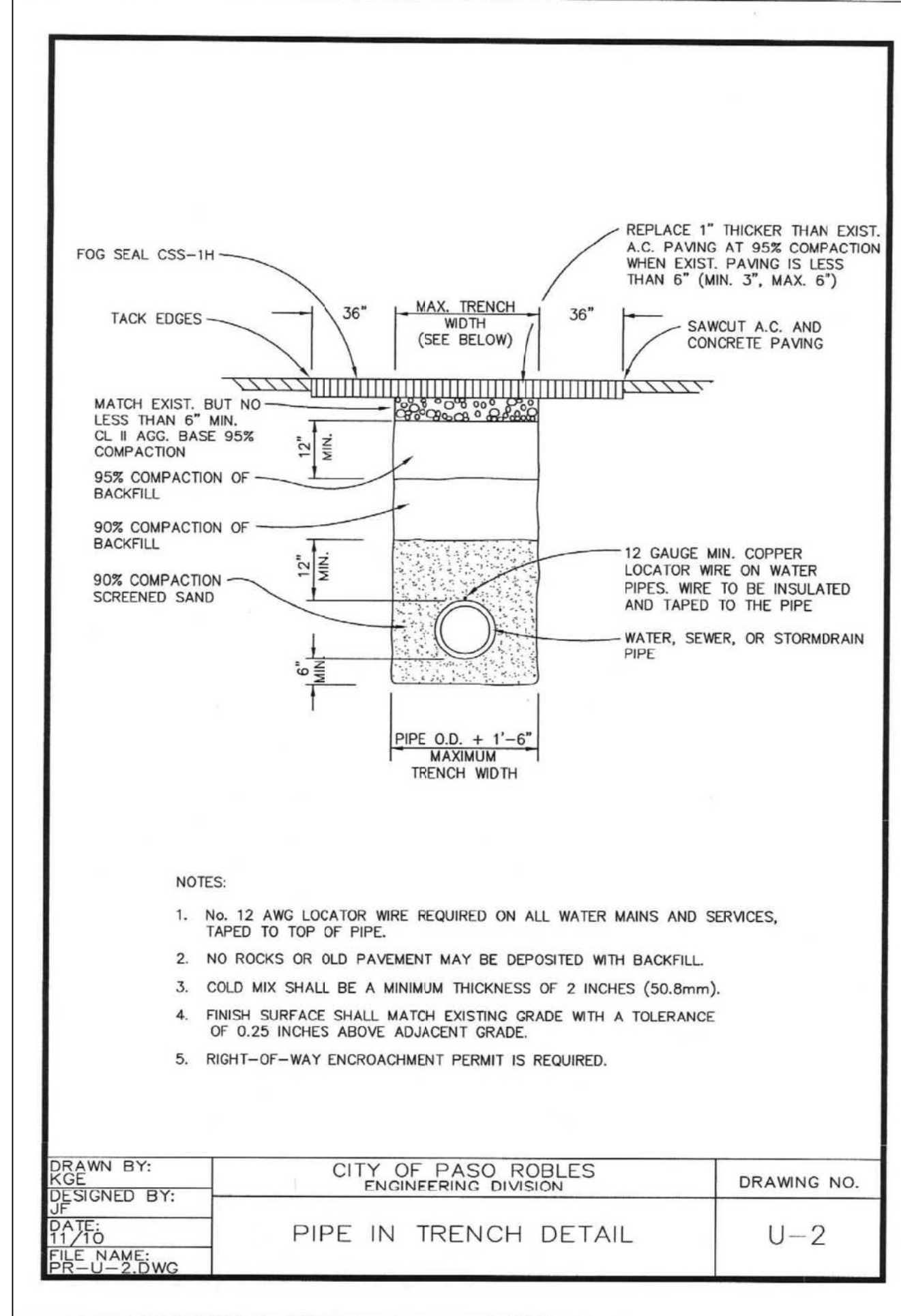

FOG SEAL CSS-1H
TACK EDGES
36" MAX. TRENCH WIDTH (SEE BELOW)
REPLACE 1" THICKER THAN EXIST. A.C. PAVING AT 95% COMPACTION WHEN EXIST. PAVING IS LESS THAN 6" (MIN. 3", MAX. 6")
SAW CUT A.C. AND CONCRETE PAVING
MATCH EXIST. BUT NO LESS THAN 6" MIN. CL. IF A.C. BASE 95% COMPACTION
95% COMPACTION OF BACKFILL
90% COMPACTION OF BACKFILL
90% COMPACTION SCREENED SAND
12 GAUGE MIN. COPPER LOCATOR WIRE ON WATER PIPES. WIRE TO BE INSULATED AND TAPED TO THE PIPE
WATER, SEWER, OR STORM DRAIN PIPE
PIPE O.D. + 1'-6" MAXIMUM TRENCH WIDTH

NOTES:

- No. 12 AWG LOCATOR WIRE REQUIRED ON ALL WATER MAINS AND SERVICES, TAPED TO TOP OF PIPE.
- NO ROCKS OR OLD PAVEMENT MAY BE DEPOSITED WITH BACKFILL.
- COLD MIX SHALL BE A MINIMUM THICKNESS OF 2 INCHES (50.8mm).
- FINISH SURFACE SHALL MATCH EXISTING GRADE WITH A TOLERANCE OF 0.25 INCHES ABOVE ADJACENT GRADE.
- RIGHT-OF-WAY ENCROACHMENT PERMIT IS REQUIRED.

DRAWN BY: RGE
DESIGNED BY: KF
DATE: 04/20/20
FILE NAME: PR-U-2.DWG

CITY OF PASO ROBLES ENGINEERING DIVISION

PIPE IN TRENCH DETAIL

DRAWING NO. U-2

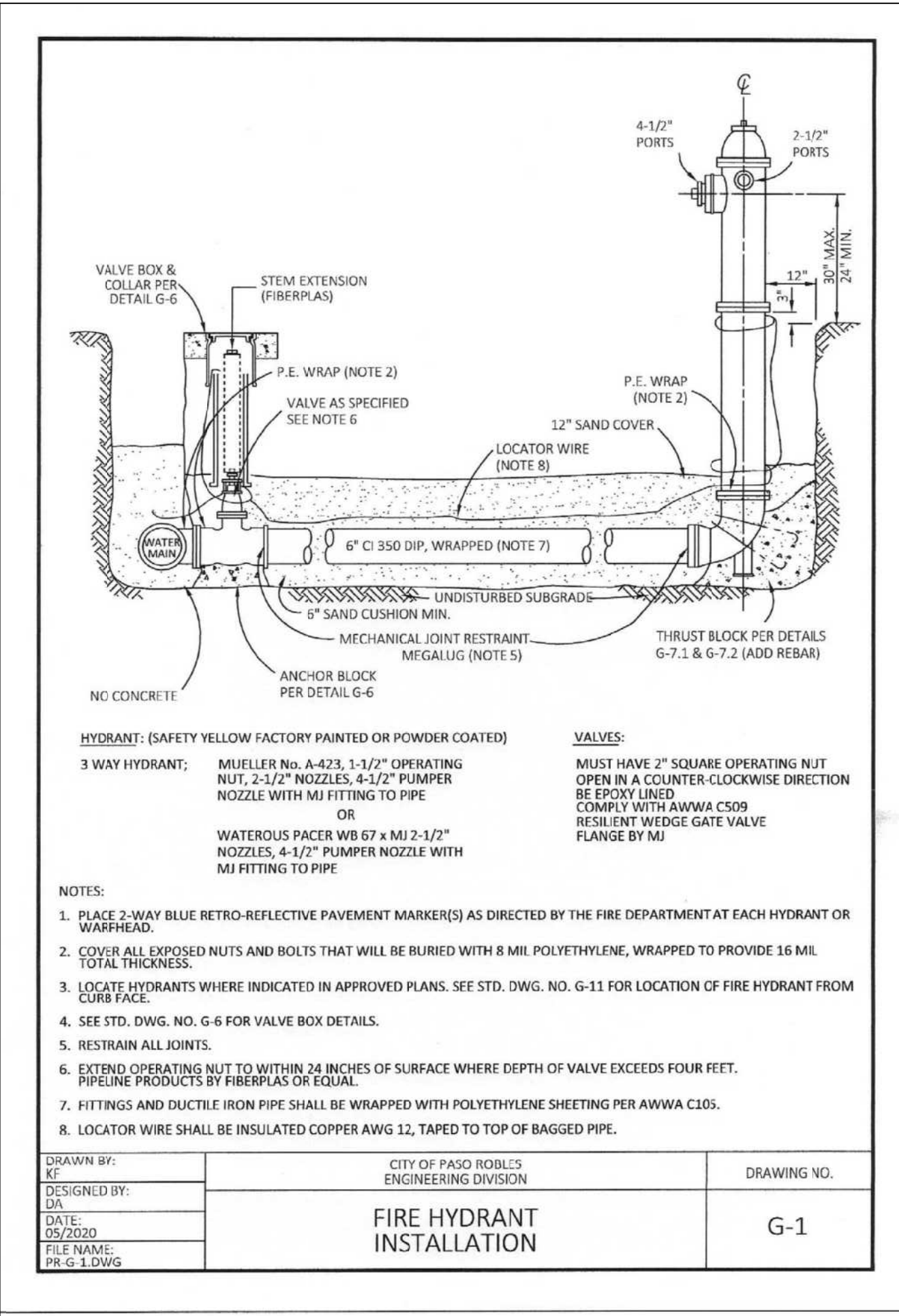

4-1/2" PORTS
3-1/2" PORTS
VALVE BOX & COLLAR PER DETAIL G-6
STEM EXTENSION (FIBERGLAS)
P.E. WRAP (NOTE 2)
VALVE AS SPECIFIED SEE NOTE 6
12" SAND COVER
LOCATOR WIRE (NOTE 8)
6" CI 350 DIP, WRAPPED (NOTE 7)
9" SAND CUSHION MIN.
MECHANICAL JOINT RESTRAINT, MEGALUG (NOTE 5)
THRUST BLOCK PER DETAILS G-7.1 & G-7.2 (ADD REBAR)
ANCHOR BLOCK PER DETAIL G-6
NO CONCRETE

HYDRANT: (SAFETY YELLOW FACTORY PAINTED OR POWDER COATED)

3 WAY HYDRANT: MUELLER No. A-423, 1-1/2" OPERATING NUT, 2-1/2" NOZZLES, 4-1/2" PUMPER NOZZLE WITH M1 FITTING TO PIPE OR WATEROUS PACER WB 67 x M1 2-1/2" NOZZLES, 4-1/2" PUMPER NOZZLE WITH M1 FITTING TO PIPE

VALVES: MUST HAVE 2" SQUARE OPERATING NUT OPEN IN A COUNTER-CLOCKWISE DIRECTION BEFORE USED. COMPLY WITH AWWA C509 RESIDENT WIDE GATE VALVE FLANGE BY MJ

NOTES:

- PLACE 2-WAY BLUE RETRO-REFLECTIVE PAVEMENT MARKER(S) AS DIRECTED BY THE FIRE DEPARTMENT AT EACH HYDRANT OR WAFFHEAD.
- COVER ALL EXPOSED NUTS AND BOLTS THAT WILL BE BURIED WITH 8 MIL POLYETHYLENE, WRAPPED TO PROVIDE 16 MIL TOTAL THICKNESS.
- LOCATE HYDRANTS WHERE INDICATED IN APPROVED PLANS. SEE STD. DWG. NO. G-11 FOR LOCATION OF FIRE HYDRANT FROM CURB FACE.
- SEE STD. DWG. NO. G-6 FOR VALVE BOX DETAILS.
- RESTRAIN ALL JOINTS.
- EXTEND OPERATING NUT TO WITHIN 24 INCHES OF SURFACE WHERE DEPTH OF VALVE EXCEEDS FOUR FEET. PIPELINE PRODUCTS BY FIBERGLAS OR EQUAL.
- FITTINGS AND DUCTILE IRON PIPE SHALL BE WRAPPED WITH POLYETHYLENE SHEETING PER AWWA C103.
- LOCATOR WIRE SHALL BE INSULATED COPPER AWG 12, TAPED TO TOP OF BAGGED PIPE.

DRAWN BY: RGE
DESIGNED BY: KF
DATE: 04/20/20
FILE NAME: PR-G-1.DWG

CITY OF PASO ROBLES ENGINEERING DIVISION

FIRE HYDRANT INSTALLATION

DRAWING NO. G-1

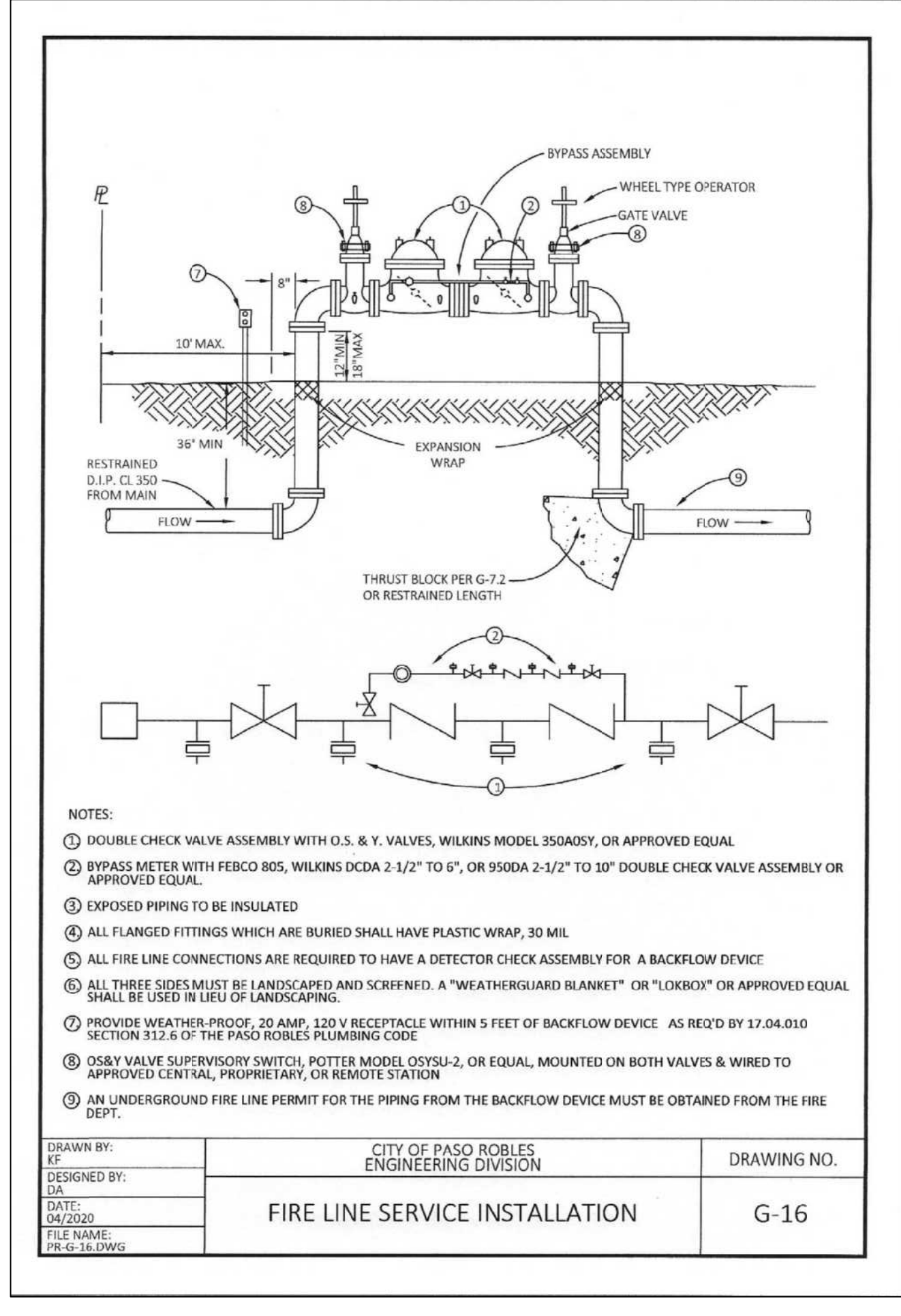

BYPASS ASSEMBLY
WHEEL TYPE OPERATOR
GATE VALVE
10" MAX.
18" MAX.
38" MIN.
RESTRAINED D.I.P. CI 350 FROM MAIN
EXPANSION WRAP
THRUST BLOCK PER G-7.2 OR RESTRAINED LENGTH

NOTES:

- DOUBLE CHECK VALVE ASSEMBLY WITH O.S. & Y. VALVES, WILKINS MODEL 350A05, OR APPROVED EQUAL.
- BYPASS METER WITH FIBCO 805, WILKINS DIDA 2-1/2" TO 6", OR 9500A 2-1/2" TO 10" DOUBLE CHECK VALVE ASSEMBLY OR APPROVED EQUAL.
- EXPOSED PIPING TO BE INSULATED.
- ALL FLANGED FITTINGS WHICH ARE BURIED SHALL HAVE PLASTIC WRAP, 30 MIL.
- ALL FIRE LINE CONNECTIONS ARE REQUIRED TO HAVE A DETECTOR CHECK ASSEMBLY FOR A BACKFLOW DEVICE.
- ALL THREE SIDES MUST BE LANDSCAPED AND SCREENED. A "WEATHERGUARD BLANKET" OR "LIDBOX" OR APPROVED EQUAL SHALL BE USED IN LIEU OF LANDSCAPING.
- PROVIDE WEATHER-PROOF, 30 AMP, 120 V RECEPTACLE WITHIN 5 FEET OF BACKFLOW DEVICE AS REQ'D BY 17.04.010 SECTION 112.6.01 OF THE PASO ROBLES PLUMBING CODE.
- OSBY VALVE SUPERVISORY SWITCH, POTTER MODEL OSYSU-2, OR EQUAL, MOUNTED ON BOTH VALVES & WIRED TO APPROVED CENTRAL, PROPRIETARY, OR REMOTE STATION.
- AN UNDERGROUND FIRE LINE PERMIT FOR THE PIPING FROM THE BACKFLOW DEVICE MUST BE OBTAINED FROM THE FIRE DEPT.

DRAWN BY: RGE
DESIGNED BY: KF
DATE: 04/20/20
FILE NAME: PR-G-16.DWG

CITY OF PASO ROBLES ENGINEERING DIVISION

FIRE LINE SERVICE INSTALLATION

DRAWING NO. G-16

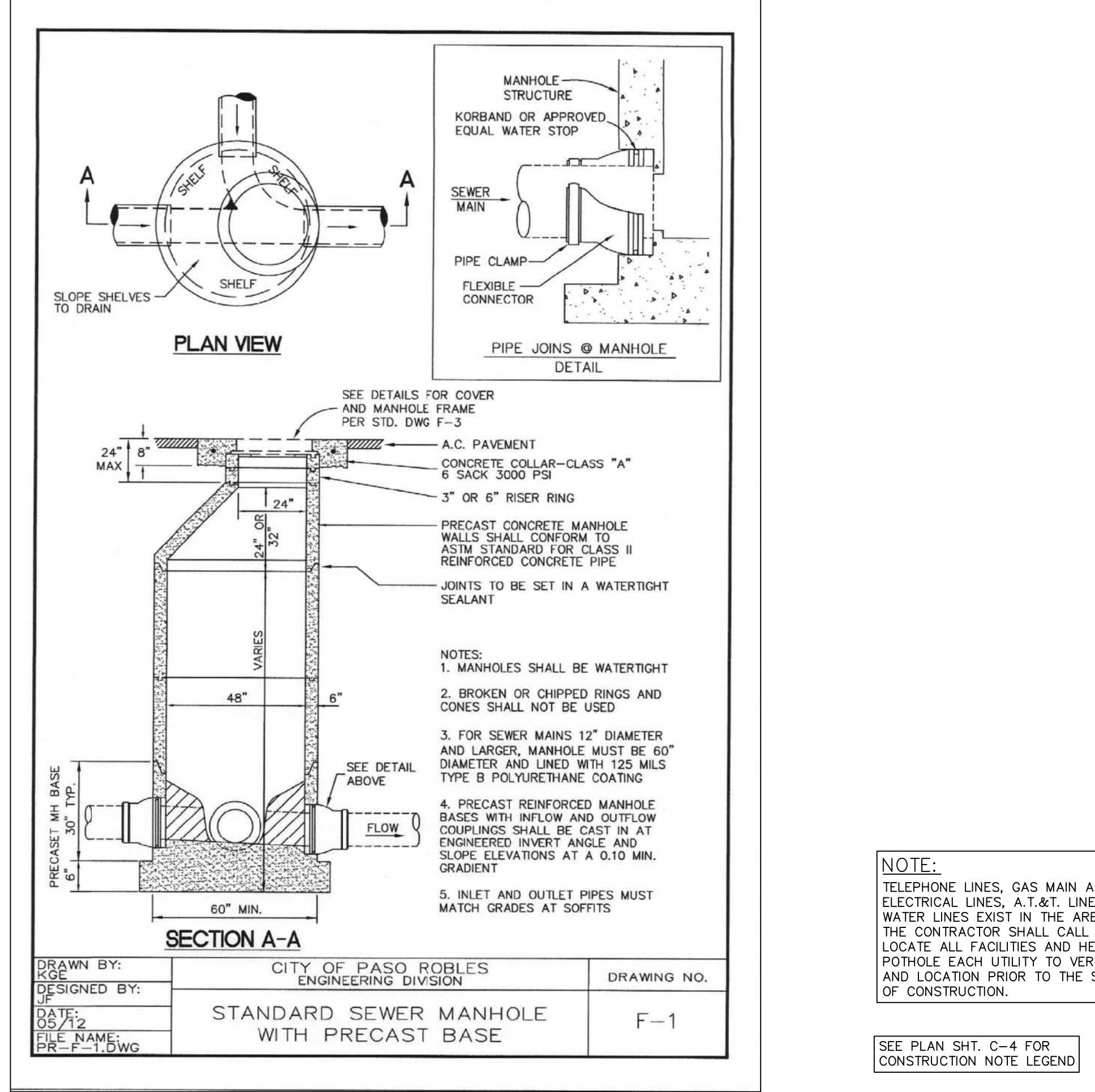

MANHOLE STRUCTURE
KORBRAND OR APPROVED EQUAL WATER STOP
SEWER MAIN
PIPE CLAMP
FLEXIBLE CONNECTOR
PIPE JOINS @ MANHOLE DETAIL

PLAN VIEW

SLOPE SHELVES TO DRAIN

SECTION A-A

SEE DETAILS FOR COVER AND MANHOLE FRAME PER STD. DWG F-3
A.C. PAVEMENT
CONCRETE COLLAR-CLASS "A" 6 SACK 3000 PSI
3" OR 6" RISER RING
PRECAST CONCRETE MANHOLE WALLS SHALL CONFORM TO ASTM STANDARD FOR CLASS II REINFORCED CONCRETE PIPE
JOINTS TO BE SET IN A WATERTIGHT SEALANT

NOTES:

- MANHOLES SHALL BE WATERTIGHT
- BROKEN OR CHIPPED RINGS AND CONES SHALL NOT BE USED
- FOR SEWER MAINS 12" DIAMETER AND LARGER, MANHOLE MUST BE 60" DIAMETER AND LINED WITH 125 MILS TYPE B POLYURETHANE COATING
- PRECAST REINFORCED MANHOLE BASES WITH INFLOW AND OUTFLOW COUPLINGS SHALL BE CAST IN AT ENGINEERED INVERT ANGLE AND SLOPE ELEVATIONS AT A 0.10 MIN. GRADIENT
- INLET AND OUTLET PIPES MUST MATCH GRADES AT SOFFITS

DRAWN BY: RGE
DESIGNED BY: KF
DATE: 04/20/20
FILE NAME: PR-F-1.DWG

CITY OF PASO ROBLES ENGINEERING DIVISION

STANDARD SEWER MANHOLE WITH PRECAST BASE

DRAWING NO. F-1

NOTE: TELEPHONE LINES, GAS MAIN AND SERVICES, ELECTRICAL LINES, A.T.&T. LINES AND PRIVATE WATER LINES EXIST IN THE AREA OF WORK. THE CONTRACTOR SHALL CALL USA TO FIELD LOCATE ALL FACILITIES AND HE SHALL THEN POTHOLE EACH UTILITY TO VERIFY DEPTH AND LOCATION PRIOR TO THE START OF CONSTRUCTION.

SEE PLAN SHT. C-4 FOR CONSTRUCTION NOTE LEGEND

UNDERGROUND SERVICE ALERT
DIAL 811
TWO WORKING DAYS BEFORE YOU DIG

W.H.M.W.CO. WATER LINE EXTENSION

STA. 11+00 TO 13+50

REV.	DESCRIPTION	DATE	APP.
1			

TARTAGLIA ENGINEERING CIVIL ENGINEERS
7360 El Camino Real, Suite E, Atascadero, CA 93422
805-466-5660 FAX: 805-466-5471

C. ARCHER

DESIGN RCT
DRAWN RCT
CHECKED XXX
SCALE AS NOTED
DWG. NO. 21-19
DATE 4/01/22
SHEET C-10 OF 18

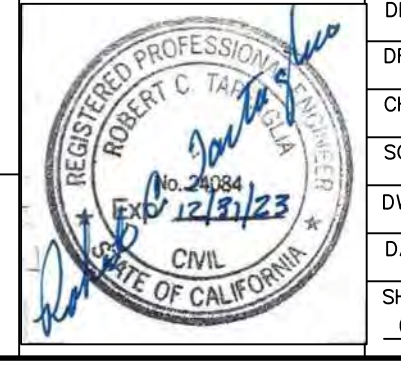

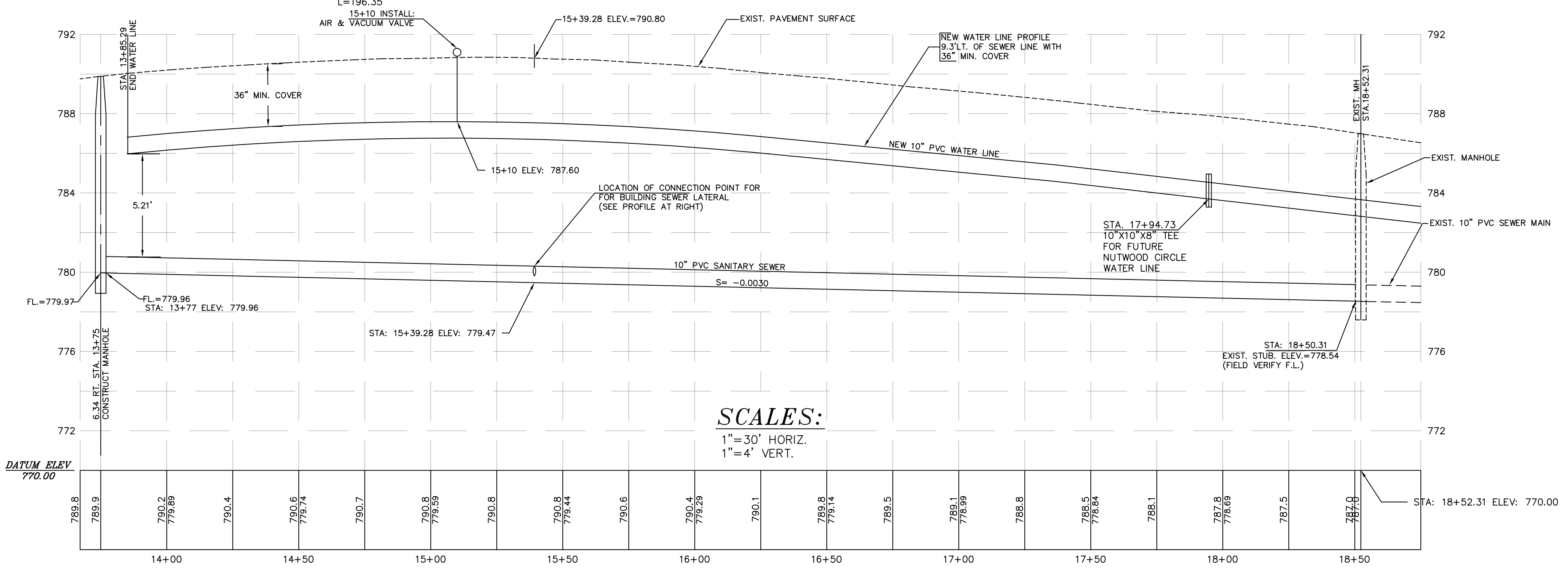
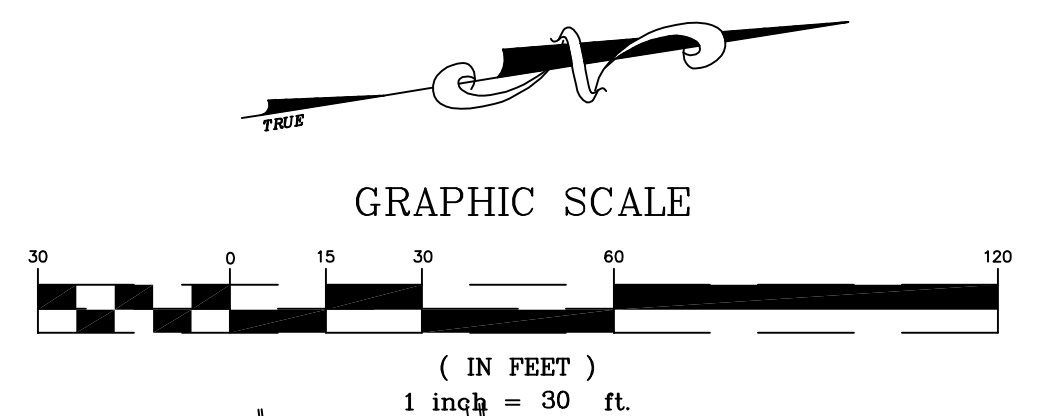
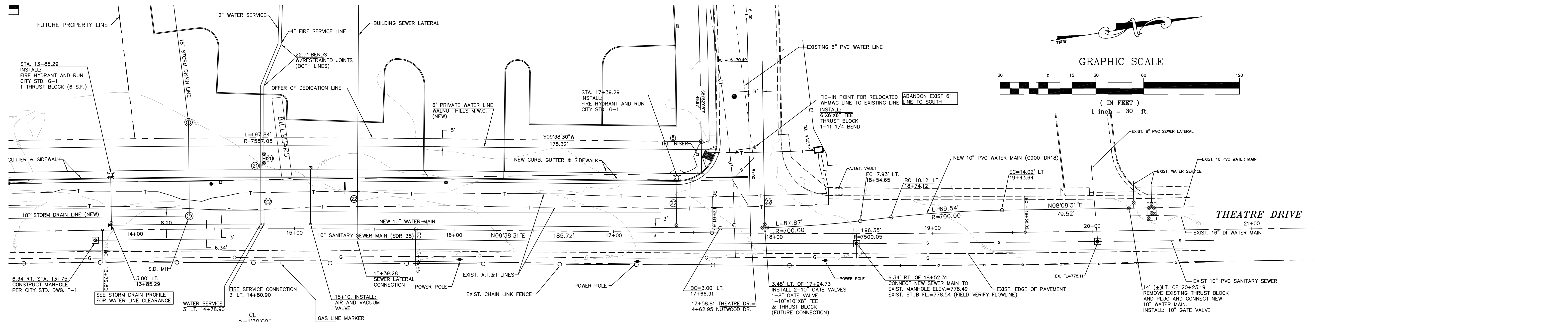

SEWER EXTENSION PROFILE

SCALES:
 1" = 30' HORIZ.
 1" = 4' VERT.

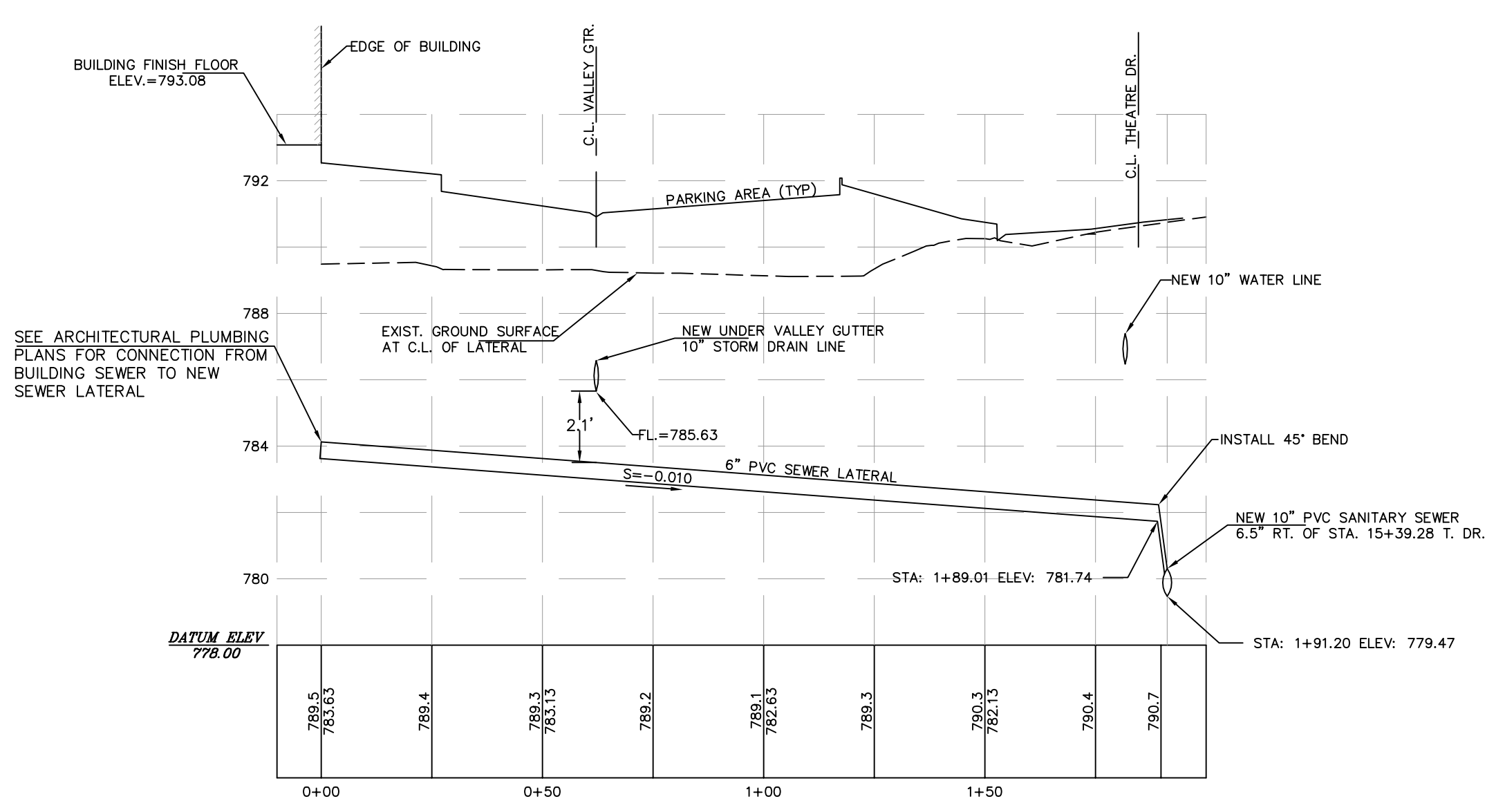

BUILDING SEWER LATERAL PROFILE

SCALES:
 1" = 30' HORIZ.
 1" = 4' VERT.

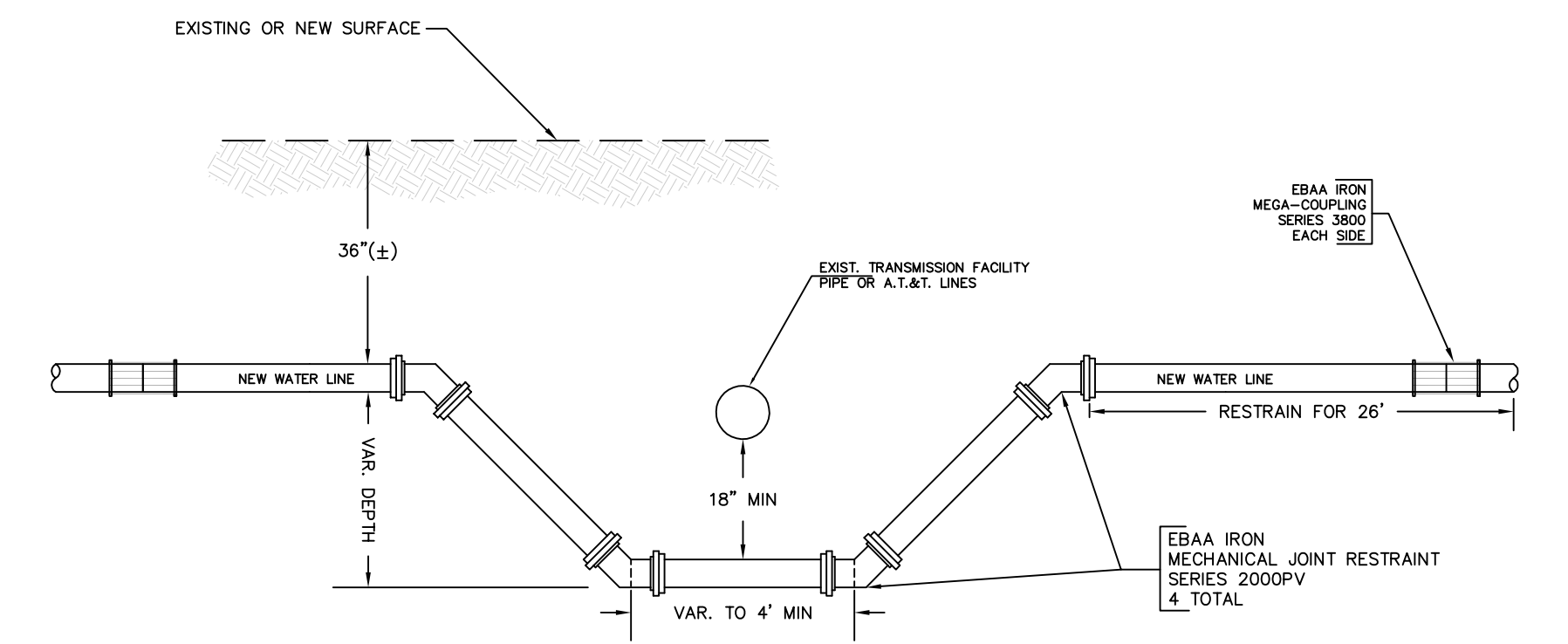

WATER MAIN/UTILITY CROSSING
 (NO SCALE)

NOTE:
 TELEPHONE LINES, GAS MAIN AND SERVICES, ELECTRICAL LINES, A.T.&T. LINES AND PRIVATE WATER LINES EXIST IN THE AREA OF WORK. THE CONTRACTOR SHALL CALL USA TO FIELD LOCATE ALL FACILITIES AND HE SHALL THEN POTHOLE EACH UTILITY TO VERIFY DEPTH AND LOCATION PRIOR TO THE START OF CONSTRUCTION.

SEE PLAN SHT. C-4 FOR CONSTRUCTION NOTE LEGEND

UNDERGROUND SERVICE ALERT
 DIAL 811
 TWO WORKING DAYS
 BEFORE YOU DIG

WATER AND SEWER EXTENSION PLAN

STA. 13+50 TO 20+23

REV.	DESCRIPTION	DATE	APP.

TE TARTAGLIA ENGINEERING
 CIVIL ENGINEERS
 7360 El Camino Real, Suite E, Atascadero, CA 93422
 805-466-5660 FAX: 805-466-5471

C. ARCHER

DESIGN RCT
 DRAWN RCT
 CHECKED XXX
 SCALE 1" = 30'
 DWG. NO. 21-19
 DATE 4/01/22
 SHEET C-11 OF 18

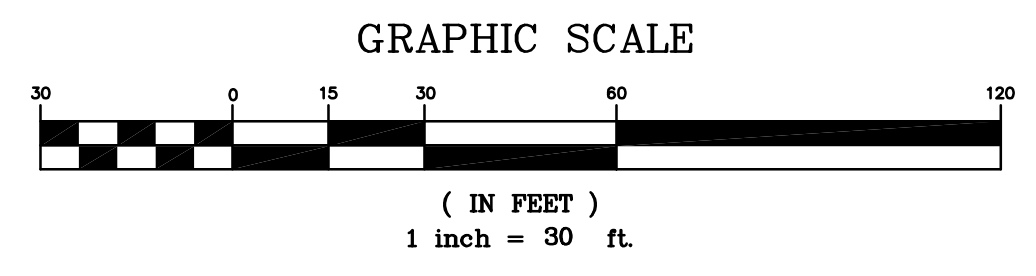
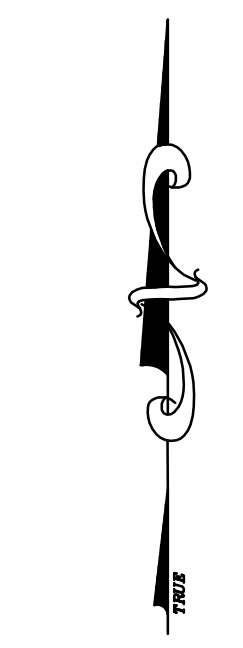
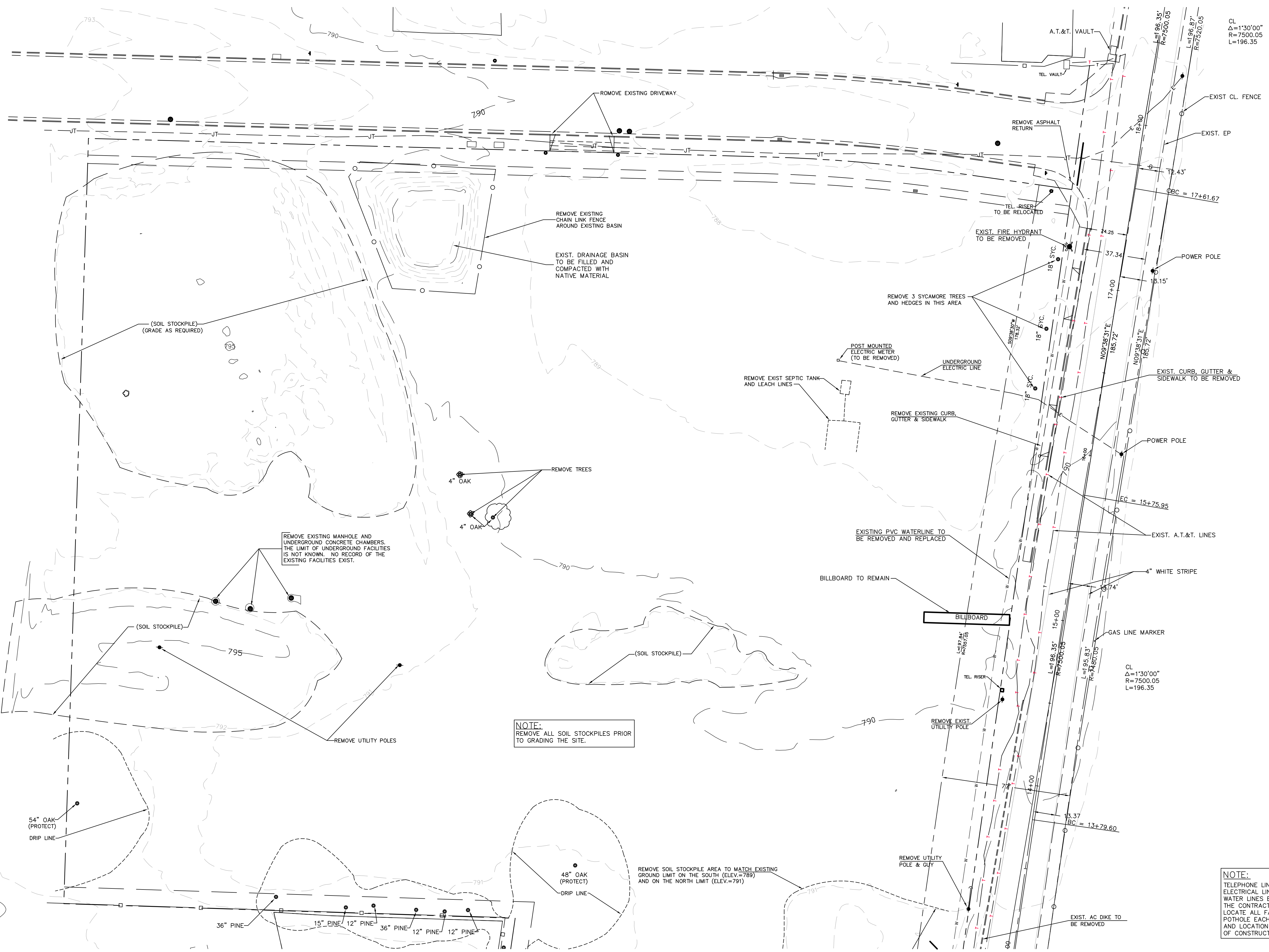

NOTE:
MISCELLANEOUS FACILITIES EXIST ON SITE SUCH AS ELECTRICAL, TELEPHONE, WATER LINES. ALL SUCH ITEMS SHALL BE REMOVED PRIOR TO GRADING OPERATIONS. THE CONTRACTOR SHALL COORDINATE WITH P.G.&E AND A.T.&T PRIOR TO THE START OF CONSTRUCTION TO INSURE THAT ALL FACILITIES ARE DISCONNECTED.

NOTE:
REMOVE ALL SOIL STOCKPILES PRIOR TO GRADING THE SITE.

NOTE:
TELEPHONE LINES, GAS MAIN AND SERVICES, ELECTRICAL LINES, A.T.&T. LINES AND PRIVATE WATER LINES EXIST IN THE AREA OF WORK. THE CONTRACTOR SHALL CALL USA TO FIELD LOCATE ALL FACILITIES AND HE SHALL THEN POTHOLE EACH UTILITY TO VERIFY DEPTH AND LOCATION PRIOR TO THE START OF CONSTRUCTION.

SEE PLAN SHT. C-4 FOR CONSTRUCTION NOTE LEGEND

UNDERGROUND SERVICE ALERT
DIAL 811
TWO WORKING DAYS
BEFORE YOU DIG

DEMOLITION PLAN

NORTH PORTION

REV.	DESCRIPTION	DATE	APP.
1			
2			
3			
4			
5			
6			
7			
8			
9			
10			

TE TARTAGLIA ENGINEERING
CIVIL ENGINEERS
7360 El Camino Real, Suite E, Atascadero, CA 93422
805-466-5660 FAX: 805-466-5471

C. ARCHER

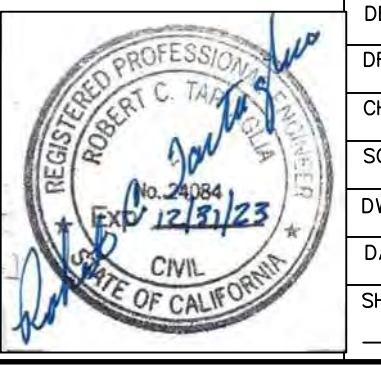

DESIGN	RCT
DRAWN	RCT
CHECKED	XXX
SCALE	1"=30'
DWG. NO.	21-19
DATE	4/01/22
SHEET	C16 of 18

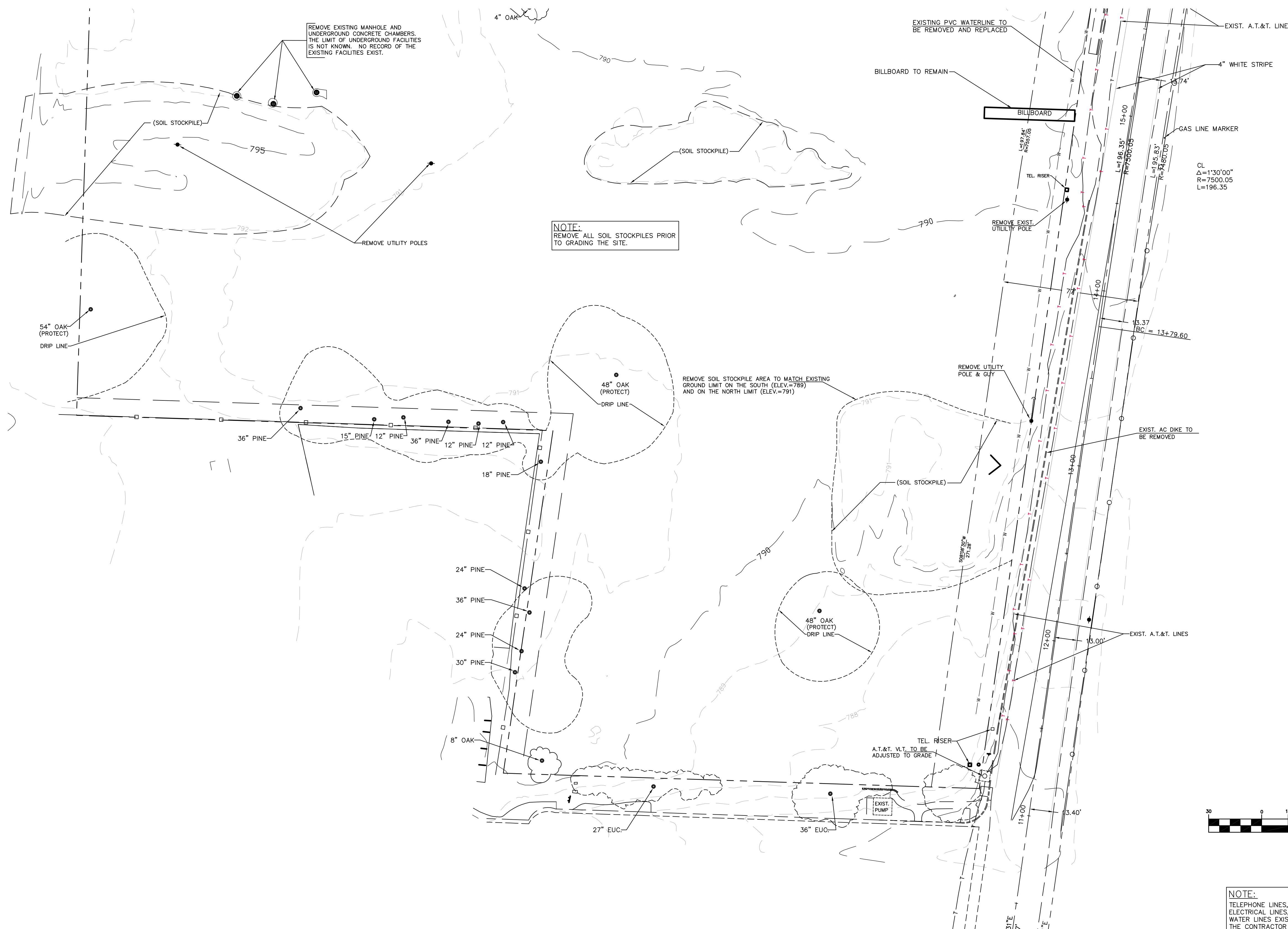

NOTE:
MISCELLANEOUS FACILITIES EXIST ON SITE SUCH AS ELECTRICAL, TELEPHONE, WATER LINES. ALL SUCH ITEMS SHALL BE REMOVED PRIOR TO GRADING OPERATIONS. THE CONTRACTOR SHALL COORDINATE WITH P.G.&E AND A.T.&T PRIOR TO THE START OF CONSTRUCTION TO INSURE THAT ALL FACILITIES ARE DISCONNECTED.

NOTE:
REMOVE ALL SOIL STOCKPILES PRIOR TO GRADING THE SITE.

CL
Δ=1'30"00"
R=7500.05
L=196.35

GRAPHIC SCALE

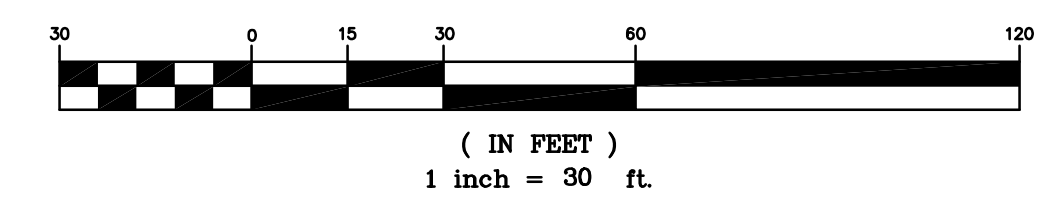

NOTE:
TELEPHONE LINES, GAS MAIN AND SERVICES, ELECTRICAL LINES, A.T.&T. LINES AND PRIVATE WATER LINES EXIST IN THE AREA OF WORK. THE CONTRACTOR SHALL CALL USA TO FIELD LOCATE ALL FACILITIES AND HE SHALL THEN FOTHOLE EACH UTILITY TO VERIFY DEPTH AND LOCATION PRIOR TO THE START OF CONSTRUCTION.

SEE PLAN SHIT. C-4 FOR CONSTRUCTION NOTE LEGEND

UNDERGROUND SERVICE ALERT
DIAL 811
TWO WORKING DAYS
BEFORE YOU DIG

DEMOLITION PLAN

SOUTH PORTION

REV.	DESCRIPTION	DATE	APP.
1			
2			
3			
4			
5			
6			
7			
8			
9			
10			

TE TARTAGLIA ENGINEERING
CIVIL ENGINEERS
7360 El Camino Real, Suite E, Atascadero, CA 93422
805-466-5660 FAX: 805-466-5471

C. ARCHER

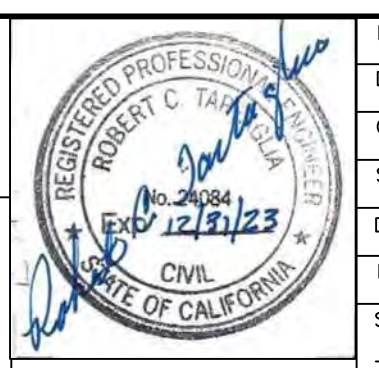

DESIGN	RCT
DRAWN	RCT
CHECKED	XXX
SCALE	1"=30'
DWG. NO.	20-19
DATE	4/01/22
SHEET	C17 of 18

EXISTING
NOT A PART

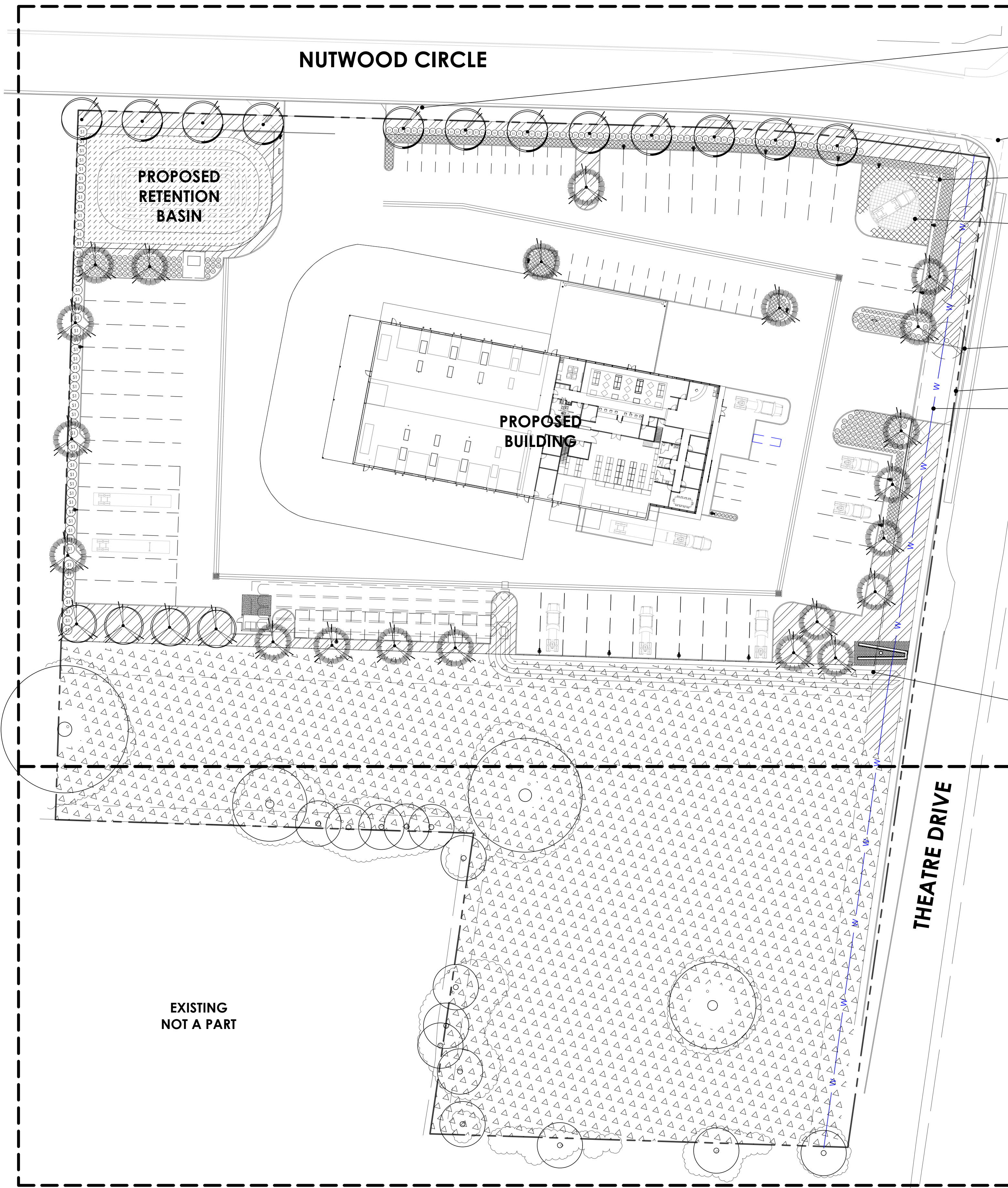

EXISTING
NOT A PART

EXISTING
NOT A PART

EXISTING
NOT A PART

25' SITE TRIANGLE (TYP.)

50' SITE TRIANGLE (TYP.)

PROPOSED 6' HIGH MOUNTED SIGN
REFER TO PLANS BY OTHERS

DISPLAY AREA

25' SITE TRIANGLE (TYP.)

PROPERTY LINE

PROPOSED 6" PRIVATE WATERLINE
REFER TO CIVIL PLANS BY OTHERS

PROPOSED 6' BLACK STEEL SITE FENCING

CONCEPTUAL LANDSCAPE ENLARGEMENT - A
REFER TO L-02

CONCEPTUAL LANDSCAPE ENLARGEMENT - B
REFER TO L-03

Preliminary

Appendix B - Water Efficient Landscape Work sheet

Reference Evapotranspiration (ET₀): 49.2
Project: Peterbilt Paso Robles, 2805 Theatre Drive, Paso Robles, CA 93446

Hydrozone # / Planting Description a	Plant Factor (PF)	Irrigation Method b	Irrigation Efficiency (IE)	ETAF (PF/IE)	Landscape Area (sq. ft.)	ETAF x Area	Estimated Total Water Use (ETWU) e
Regular Landscape Areas							
Very Low	0.1	drip	0.81	0.12	-	-	-
Low	0.25	drip	0.81	0.31	95,165.00	10,853.40	331,071.96
Medium	0.5	drip	0.81	0.62	4,039.00	2,493.21	76,029.87
High	0.8	drip	0.81	0.99	-	-	-
Non-irrigated	0.0	n/a	0.1	0.00	109,279.00	-	-
Totals					148,483.00	13,346.60	407,124.84
Special Landscape Areas							
Turf	1	-	-	-	-	-	-
Totals					-	-	-
ETWU Total						407,124.84	-
Maximum Allowed Water Allowance (MAWA):						2,028,106.44	-

a Hydrozone #/Planting Description E.g. 1.) front lawn 2.) medium water use planting	b Irrigation Method overhead spray or drip	c Irrigation Efficiency 0.75 for spray head 0.81 for drip	d ETWU (Annual Gallons Required) = (EA x SA) x ETAF where EA is a conversion factor that converts acre-inches per acre per year to gallons per square foot per year. EA is the total landscape area in square feet, SA is the total special landscape area in square feet, and ETAF is .55 for residential areas and 0.45 for non-residential areas.	e MAWA (Annual Gallons Allowed) = (EA x SA) x ETAF where EA is a conversion factor that converts acre-inches per acre per year to gallons per square foot per year. EA is the total landscape area in square feet, SA is the total special landscape area in square feet, and ETAF is .55 for residential areas and 0.45 for non-residential areas.
All Landscape Areas	Regular	Total ETAF x Area (B)	Total ETAF x Area (B)	Total ETAF x Area (B)
Total ETAF x Area (B)	Total ETAF x Area (B)	13,346.60	13,346.60	13,346.60
Total Area (A+C)	Total Area (A)	148,483.00	148,483.00	148,483.00
Stipewide ETAF (B+D) = (A+C)	Average ETAF (B+A)	0.09	0.09	0.09

GENERAL NOTES

- MINIMUM PLANT SIZES: STREET TREES (24"BOX), SITE TREES (15 GAL.), SHRUBS (1 GAL.), GROUNDCOVER (FLATS)
- IRRIGATION SYSTEM TO BE INSTALLED AS A PART OF SITE CONSTRUCTION. SYSTEM SHALL BE UNDERGROUND, AUTOMATIC WITH POP-UP SPRAY HEADS, "SMART" CONTROLLER AND AUTOMATIC RAIN SHUTOFF. LOW PRECIPITATION RATE HEADS TO BE USED TO MINIMIZE RUNOFF.
- POINT OF CONNECTION FOR WATER SUPPLY, SHALL BE BY A NEW LANDSCAPE SUB METER.
- ALL PLANTING AREAS SHALL RECEIVE A 3" LAYER OF MEDIUM BARK MULCH AFTER INSTALLATION.
- ALL PLANT MATERIAL SHALL CONFORM TO THE CITY OF PASO ROBLES OR STATE OF CALIFORNIA MODEL WATER CONSERVATION ORDINANCE.
- ALL PLANTING AND IRRIGATION SHALL BE INSTALLED PER THE CITY OF PASO ROBLES STANDARDS AND CODES.
- FOR SITE WORK, ARCHITECTURAL, AND GRADING/DRAINAGE INFORMATION SEE PLANS BY OTHERS.
- ALL AREAS BEYOND THE AREA OF WORK THAT ARE DISTURBED BY CONSTRUCTION SHALL BE RETURNED TO ORIGINAL CONDITION. DRAWINGS ARE FOR DESIGN AND REVIEW PURPOSES ONLY AND SHALL NOT BE USED AS CONSTRUCTION DOCUMENTS.
- TREES PLANTED IN AN AREA LESS THAN 8' WIDE SHALL BE INSTALLED WITH A LINEAR ROOT BARRIER TO PROTECT AGAINST HARDSCAPE DAMAGE.
- STREET TREES ARE TO BE SELECTED FROM THE CITY OF PASO ROBLES APPROVED TREE LIST.

CONCEPTUAL PLANTING LEGEND

<p>STREET TREES - 24" BOX <i>Chinese Pistache - Pistacia chinensis</i> * <i>London Plan Tree - Platanus acerifolia</i> *</p> <p>PERIMETER SCREENING TREES - 15 GAL. <i>Japanese Zelkova - Zelkova serrata</i> * <i>Golden Locust - Robinia p. 'frisia'</i> * <i>Chinese Elm - Ulmus Parvifolia</i> *</p> <p>OAK TREE SPECIES (MITIGATION) - 15 GAL.</p> <p>EXISTING TREES TO REMAIN</p> <p>EXISTING TREES TO BE REMOVED</p> <p>HYDROSEED MIX - SEED S&S Seeds - Basic Native Erosion Control Mix</p> <p>HYDROSEED MIX - SEED S&S Seeds - Basic Native Mix Non-irrigated</p>	<p>MEDIUM FLOWERING SHRUBS - 1 GAL. <i>Italian Buckthorn - Rhamnus alaternus</i> * <i>Clara Indian Hawthorn - Rhaphiolepis l. 'Clara'</i> * <i>Little John Butterflybush - Callistemon 'Little John'</i> * <i>Concha ceanothus - Ceanothus 'Concha'</i></p> <p>SMALL FLOWERING SHRUBS - 1 GAL. <i>Red Hot Poker - Kniphofia uvaria</i> * <i>Hidcote Lavender - Lavandula a. 'Hidcote'</i> * <i>Hardy Yellow Ice Plant - Delosperma nubigenis</i> * <i>Blue Chalksticks - Senecio serpens</i></p> <p>SMALL ORNAMENTAL GRASSES - 1 GAL. <i>Berkeley Sedge - Carex divulsa</i> * <i>Blue Oat Grass - Helictotrichon sempervirens</i> * <i>Siskiyou Blue Fescue - Feluca 'Siskiyou Blue'</i></p> <p>L.I.D. PLANTING - FLATS <i>Yarrow - Achillea millefolium</i> * <i>Small Cape Rush - Chondropetalus tectorum</i> * <i>Elk Blue CA Gray Rush - Juncus patens 'Blue Elk'</i> * <i>Pine Muhly - Muhlenbergia dubia</i></p> <p>FLOWERING GROUNDCOVERS - FLATS <i>Creeping Myoporum - Myoporum p. 'Pulch Creek'</i> * <i>Bearberry Cotoneaster - Cotoneaster d. 'Low Fast'</i> * <i>Trailing Rosemary - Rosmarinus officinalis 'Prostratus'</i> *</p> <p>* - Preferred Plants</p>
---	---

CONCEPTUAL LANDSCAPE PLAN

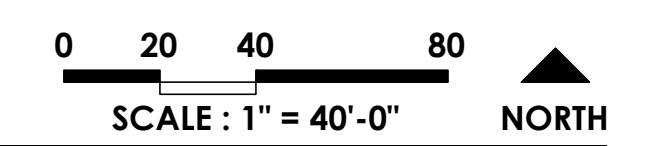

VICINITY MAP

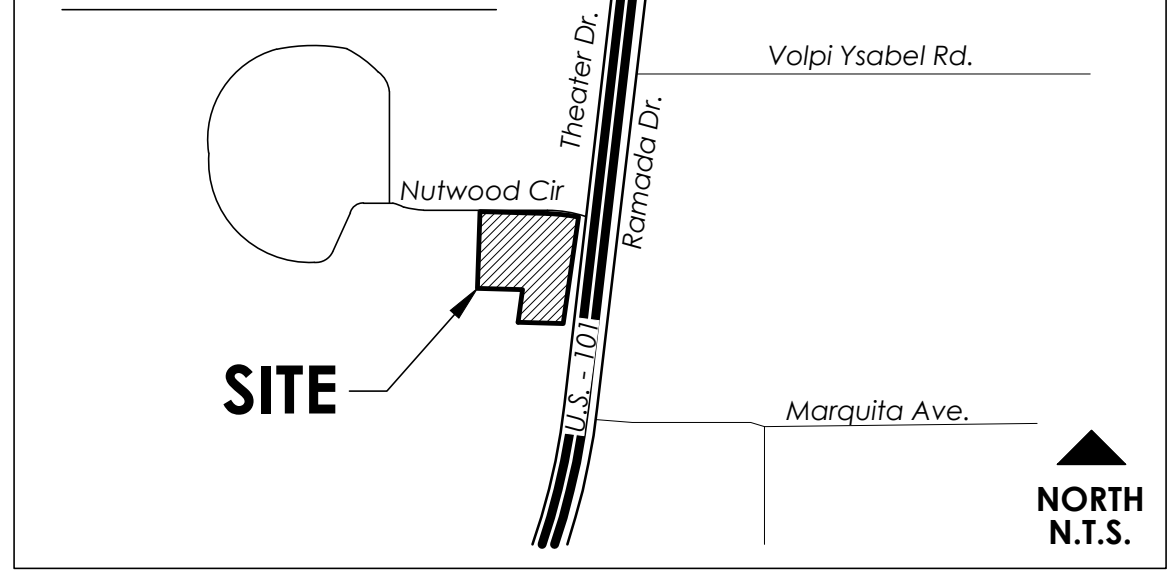

SHEET TITLE

CONCEPTUAL LANDSCAPE PLAN

OWNER Craig Archer
3030 Ramada Drive
Paso Robles, California 93446

DATE 2022.12.15
22219

SHEET NO.

L-01

PETERBILT PASO ROBLES

2805 THEATRE DRIVE // PASO ROBLES, CALIFORNIA 93446

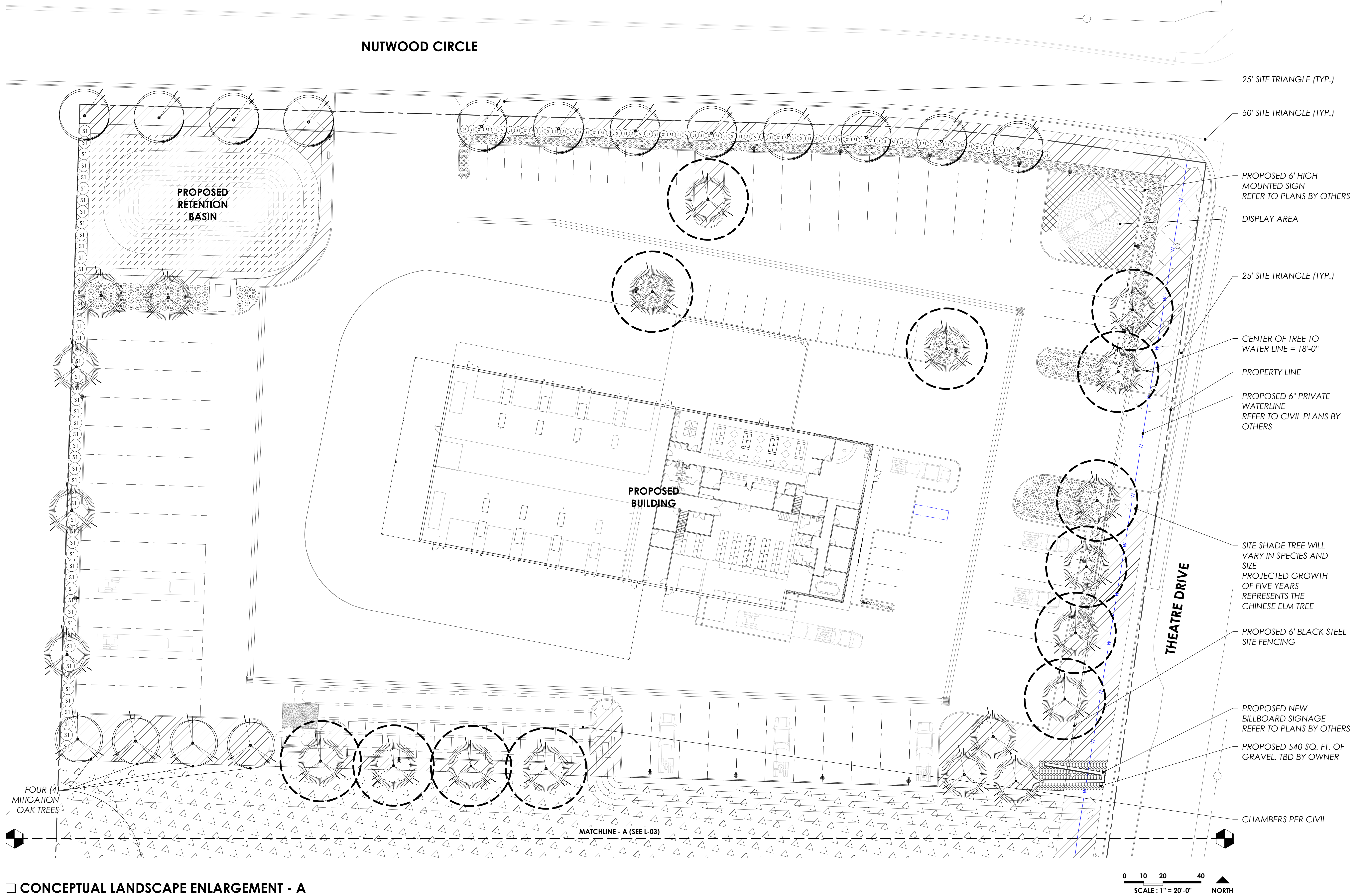

CONCEPTUAL LANDSCAPE ENLARGEMENT - A

CONCEPTUAL PLANTING LEGEND

<p>STREET TREES - 24" BOX</p> <p>Chinese Pistache - <i>Pistacia chinensis</i> *</p> <p>London Plan Tree - <i>Platanus acerifolia</i> *</p>	<p>EXISTING TREES TO REMAIN</p> <p>EXISTING TREES TO BE REMOVED</p>	<p>SMALL FLOWERING SHRUBS - 1 GAL.</p> <p>Red Hot Poker - <i>Kniphofia uvaria</i> *</p> <p>Hidcote Lavender - <i>Lavandula a. 'Hidcote'</i> *</p> <p>Hardy Yellow Ice Plant - <i>Delosperma nubigenis</i></p> <p>Blue Chalksticks - <i>Senecio serpens</i></p>	<p>HYDROSEED MIX - SEED</p> <p>S&S Seeds - Basic Native Erosion Control Mix</p>	<p>L.I.D. PLANTING - FLATS</p> <p>Yarrow - <i>Achillea millefolium</i> *</p> <p>Small Cape Rush - <i>Chondropetalus tectorum</i> *</p> <p>Elk Blue CA Gray Rush - <i>Juncus patens 'Blue Elk'</i> *</p> <p>Pine Muhly - <i>Muhlenbergia dubia</i></p>
<p>PERIMETER SCREENING TREES - 15 GAL.</p> <p>Japanese Zelkova - <i>Zelkova serrata</i> *</p> <p>Golden Locust - <i>Robinia p. 'Frisia'</i> *</p> <p>Chinese Elm - <i>Ulmus Parvifolia</i> *</p>	<p>MEDIUM FLOWERING SHRUBS - 1 GAL.</p> <p>Italian Buckthorn - <i>Rhamnus alaternus</i> *</p> <p>Clara Indian Hawthorn - <i>Raphiolepis l. 'Clara'</i> *</p> <p>Little John Bottlebrush - <i>Callistemon 'Little John'</i></p> <p>Concha ceanothus - <i>Ceanothus 'Concha'</i></p>	<p>SMALL ORNAMENTAL GRASSES - 1 GAL.</p> <p>Berkeley Sedge - <i>Carex divulsa</i> *</p> <p>Blue Oat Grass - <i>Helictotrichon sempervirens</i> *</p> <p>Siskiyou Blue Fescue - <i>Festuca 'Siskiyou Blue'</i></p>	<p>HYDROSEED MIX - SEED</p> <p>S&S Seeds - Basic Native Mix Non-irrigated</p>	<p>FLOWERING GROUNDCOVERS - FLATS</p> <p>Creeping Myoporum - <i>Myoporum p. 'Putah Creek'</i> *</p> <p>Bearberry Cotoneaster - <i>Cotoneaster d. 'Low Fast'</i> *</p> <p>Trailing Rosemary - <i>Rosmarinus officinalis 'Prostratus'</i> *</p>

* - Preferred Plants

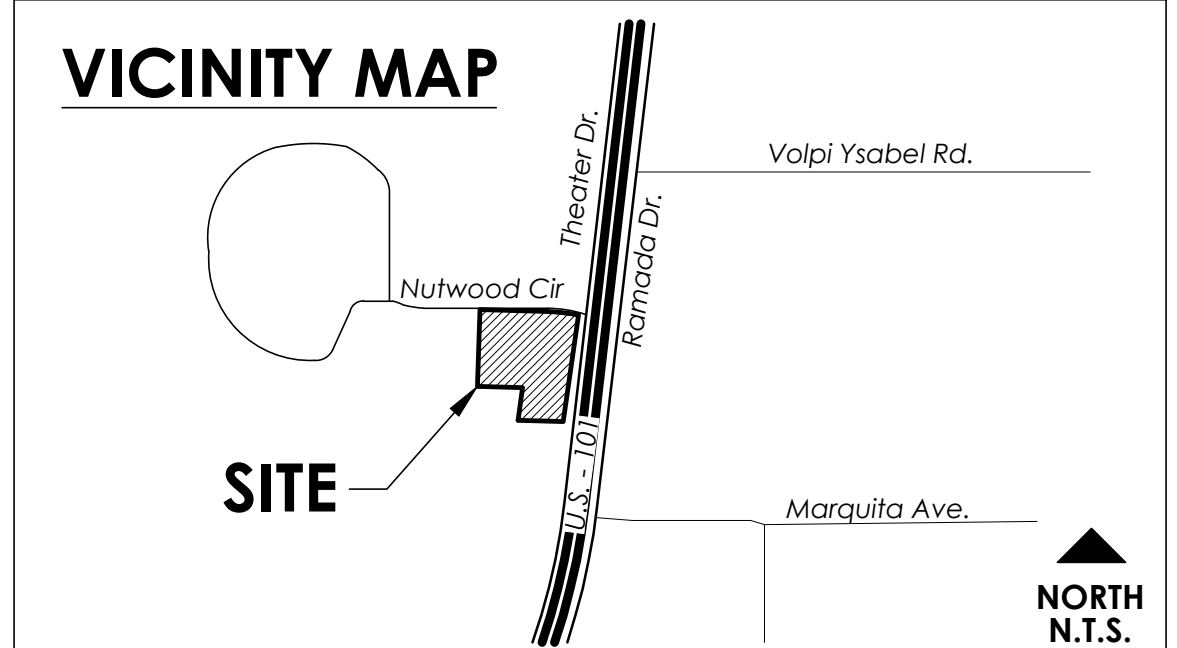

SHEET TITLE

CONCEPTUAL LANDSCAPE ENLARGEMENT - A

OWNER: Craig Archer
 3030 Ramada Drive
 Paso Robles, California 93446

DATE: 2022.12.15
 22219

SHEET NO.

L-02

PETERBILT PASO ROBLES

2805 THEATRE DRIVE // PASO ROBLES, CALIFORNIA 93446

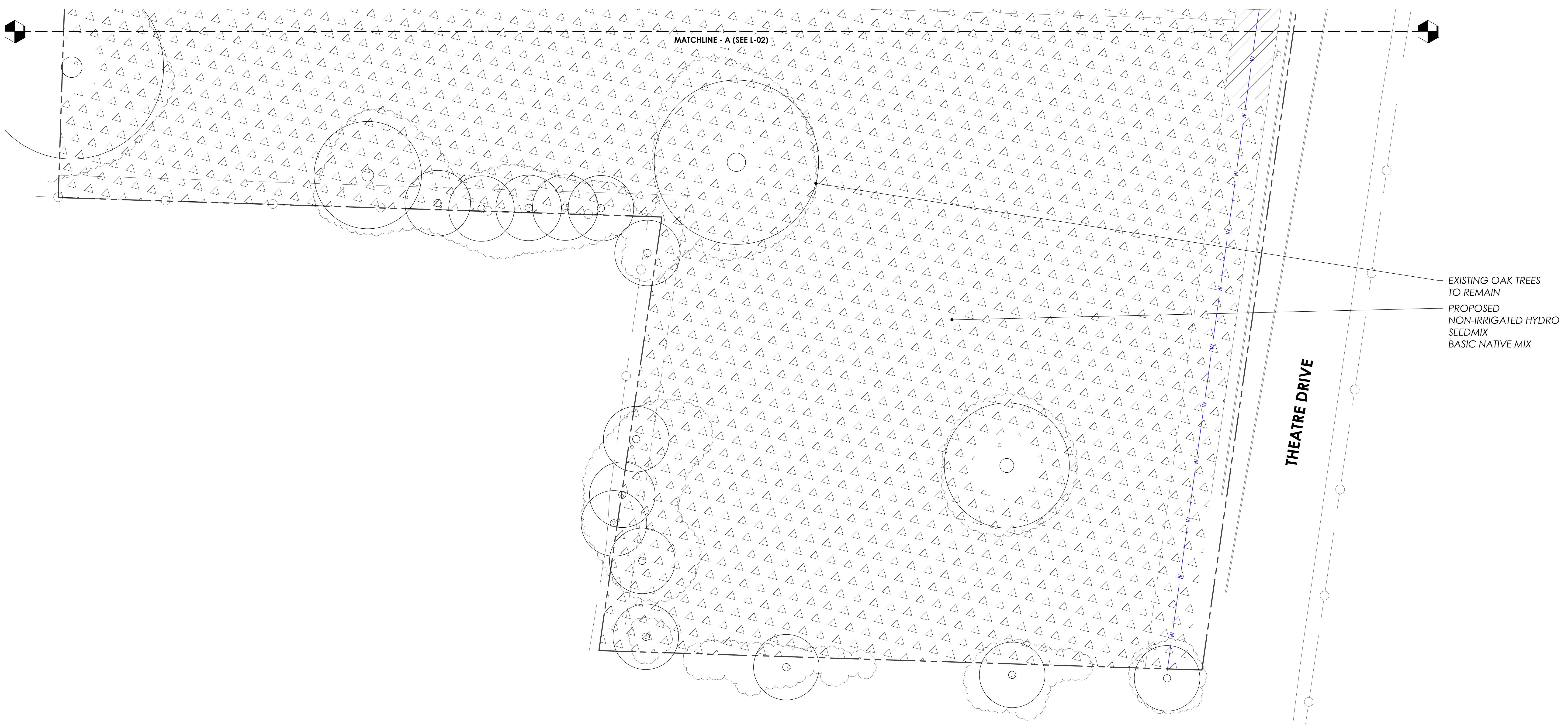

EXISTING OAK TREES TO REMAIN
 PROPOSED NON-IRRIGATED HYDRO SEED MIX
 BASIC NATIVE MIX

THEATRE DRIVE

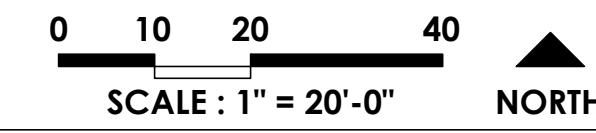

CONCEPTUAL LANDSCAPE ENLARGEMENT - B

CONCEPTUAL PLANTING LEGEND

STREET TREES - 24" BOX Chinese Pistache - <i>Pistacia chinensis</i> * London Plan Tree - <i>Platanus acerifolia</i> * PERIMETER SCREENING TREES - 15 GAL. Japanese Zelkova - <i>Zelkova serrata</i> * Golden Locust - <i>Robinia p. 'Frisia'</i> * Chinese Elm - <i>Ulmus Parvifolia</i> * OAK TREE SPECIES (MITIGATION) - 15 GAL.	EXISTING TREES TO REMAIN EXISTING TREES TO BE REMOVED MEDIUM FLOWERING SHRUBS - 1 GAL. Italian Buckthorn - <i>Rhamnus alaternus</i> * Clara Indian Hawthorn - <i>Rhaphiolepis l. 'Clara'</i> * Little John Bottlebrush - <i>Callistemon 'Little John'</i> Concha ceanothus - <i>Ceanothus 'Concha'</i>	SMALL FLOWERING SHRUBS - 1 GAL. Red Hot Poker - <i>Kniphofia uvaria</i> * Hidcote Lavender - <i>Lavandula a. 'Hidcote'</i> * Hardy Yellow Ice Plant - <i>Delosperma nubigenis</i> Blue Chalksticks - <i>Senecio serpens</i> SMALL ORNAMENTAL GRASSES - 1 GAL. Berkeley Sedge - <i>Carex divulsa</i> * Blue Oat Grass - <i>Helictotrichon sempervirens</i> * Siskiyou Blue Fescue - <i>Festuca 'Siskiyou Blue'</i>	HYDROSEED MIX - SEED S&S Seeds - Basic Native Erosion Control Mix HYDROSEED MIX - SEED S&S Seeds - Basic Native Mix Non-irrigated	L.I.D. PLANTING - FLATS Yarrow - <i>Achillea millefolium</i> * Small Cape Rush - <i>Chandropetalus tectorum</i> * Elk Blue CA Gray Rush - <i>Juncus patens 'Blue Elk'</i> * Pine Muhly - <i>Muhlenbergia dubia</i> FLOWERING GROUNDCOVERS - FLATS Creeping Myoporum - <i>Myoporum p. 'Putah Creek'</i> * Bearberry Cotoneaster - <i>Cotoneaster d. 'Low Fast'</i> * Trailing Rosemary - <i>Rosmarinus officinalis 'Prostratus'</i> * * - Preferred Plants
---	--	---	--	--

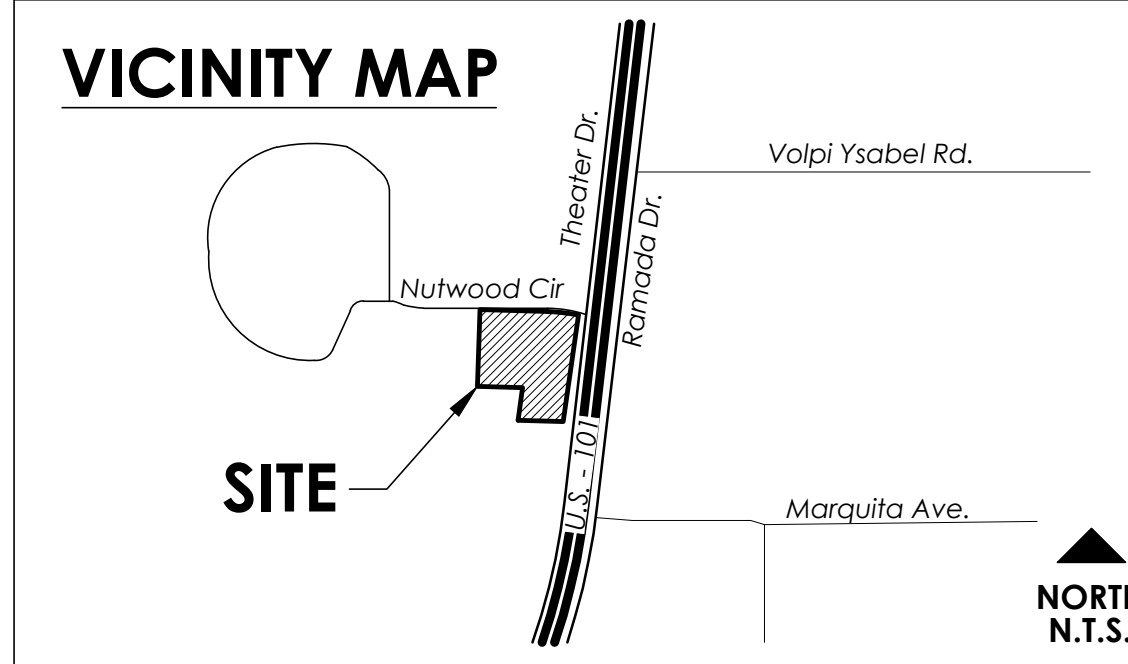

SHEET TITLE
CONCEPTUAL LANDSCAPE ENLARGEMENT - B

OWNER Craig Archer
 3030 Ramada Drive
 Paso Robles, California 93446

DATE 2022.12.15
 22219

SHEET NO.

L-03



Chinese Pistache



London Plane Tree



Japanese Zelkova



Golden Locust

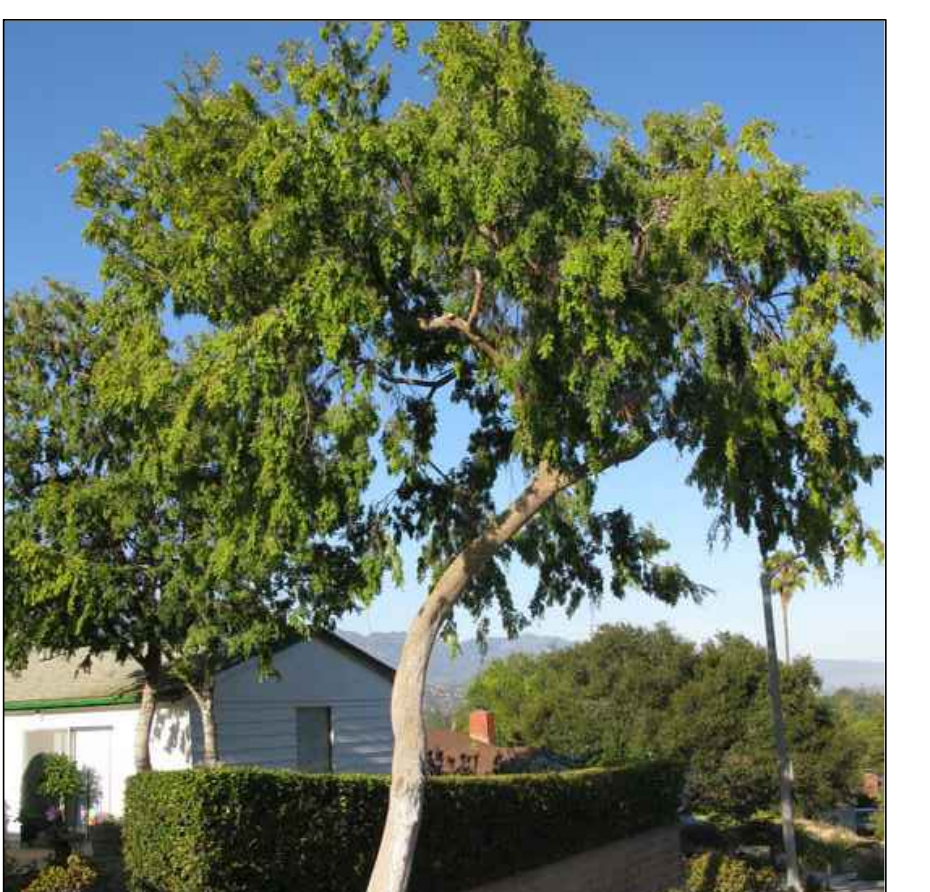

Chinese Elm



Oak



Italian Buckthorn



Clara Indian Hawthorn



Hidcote Lavender



Red Hot Poker



Berkeley Sedge



Blue Oat Grass



Yarrow



Small Cape Rush



Elk Blue California Gray Rush



Myoporum



Lowfast Cotoneaster



Trailing Rosemary

NOTE:
PLANT IMAGERY SHOWN IS REPRESENTATIVE ONLY.
FINAL SELECTIONS MAY VARY. SEE CONCEPTUAL
PLANTING LEGEND FOR MORE INFORMATION.

PETERBILT PASO ROBLES
2805 THEATRE DRIVE // PASO ROBLES, CALIFORNIA 93446

SHEET TITLE
PLANT IMAGERY

OWNER Craig Archer
3030 Ramada Drive
Paso Robles, California 93446

DATE 2022.12.15
22219

SHEET NO.
L-04

ARCHITECT STAMP CONSULTANT STAMP



OWNER INFO
Craig Archer
3030 Ramada Drive, Paso Robles CA

Peterbilt Paso Robles

2805 Theatre Drive
Paso Robles, CA 93446
APN: 009-851-022

DATE	ISSUE
08AUG22	DEVELOPMENT PLAN REVIEW
03OCT22	PLANNING COMMISSION SUBMITTAL

SUBMITTALS & REVISORS	

JOB NUMBER
2138

AGENCY APPROVAL

OVERALL ARCHITECTURAL SITE PLAN

AS101

#	OVERALL SITE PLAN KEYNOTES
10.01	5' EXTERIOR DIRECTIONAL SIGNAGE
10.02	EXISTING BILLBOARD TO BE REMOVED AT END OF CONSTRUCTION
10.03	PROPOSED 6' TALL MONUMENT SIGN
26.01	PROPOSED LOCATION OF ELECTRICAL TRANSFORMER
26.02	POLE MOUNTED LED AREA LIGHTS
32.01	PROPOSED CONCRETE PAD AREA
32.02	CURB NOTCH ADDED TO PROTECT TREES. REFER TO LANDSCAPE PLAN
32.03	6" BLACK STEEL SITE FENCING
32.04	PROPOSED 30' BILLBOARD

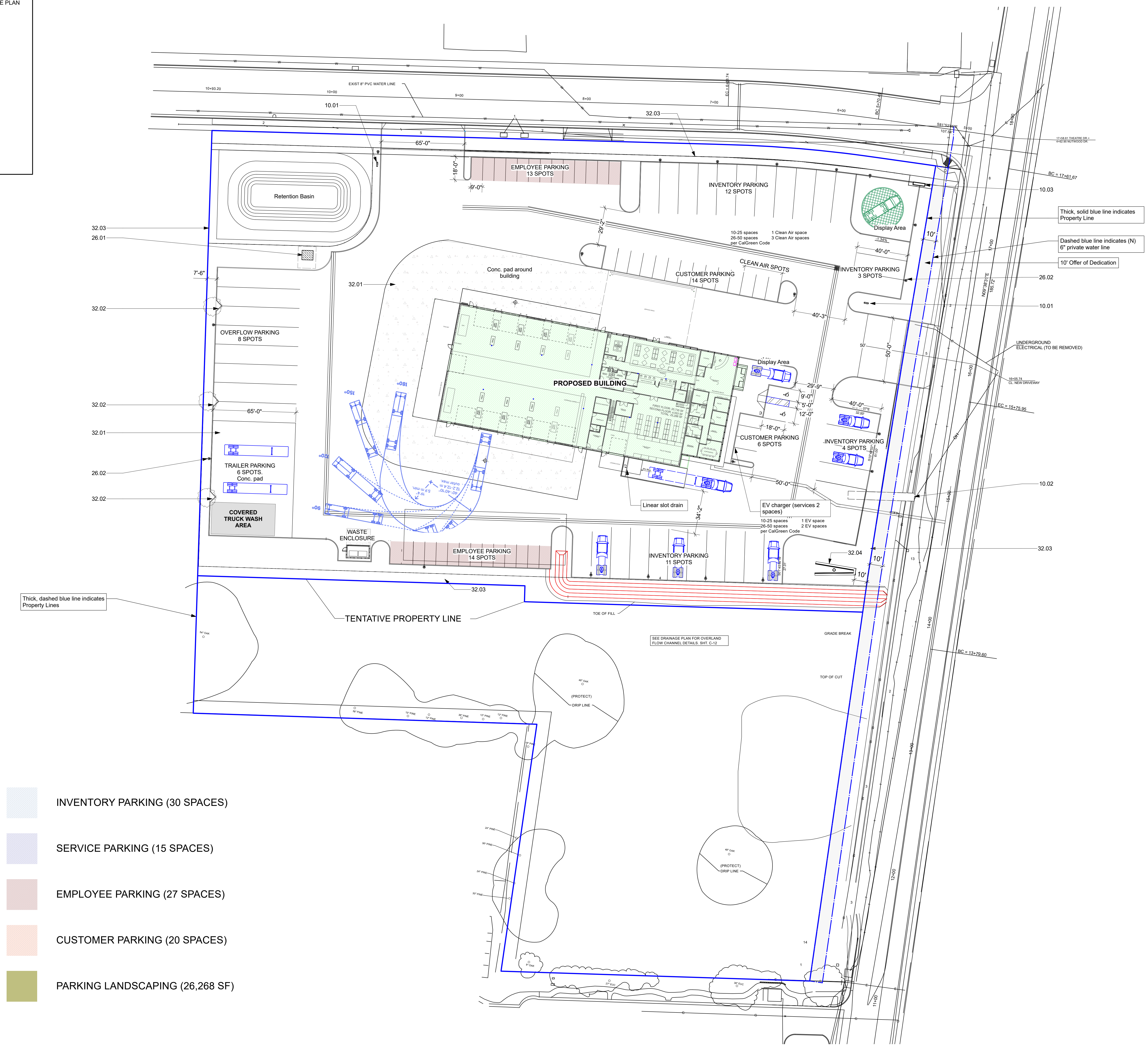

- INVENTORY PARKING (30 SPACES)
- SERVICE PARKING (15 SPACES)
- EMPLOYEE PARKING (27 SPACES)
- CUSTOMER PARKING (20 SPACES)
- PARKING LANDSCAPING (26,268 SF)

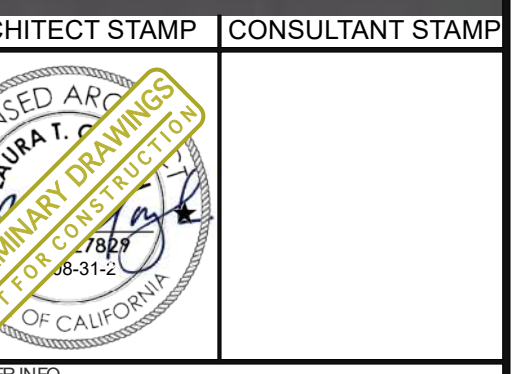

OWNER:
 Craig Archer
 3030 Ramada Drive, Paso Robles CA

Peterbilt Paso Robles
 2805 Theatre Drive
 Paso Robles, CA 93446
 APN: 009-851-022

PROJECT DATA

SUBMITTALS & REVISIONS
 DATE ISSUE
 03 JUN 22 DEVELOPMENT PLAN RESUBMITTAL

JOB NUMBER
2138

AGENCY APPROVAL

PREP FILE
SITE FENCING EXHIBIT
AS111

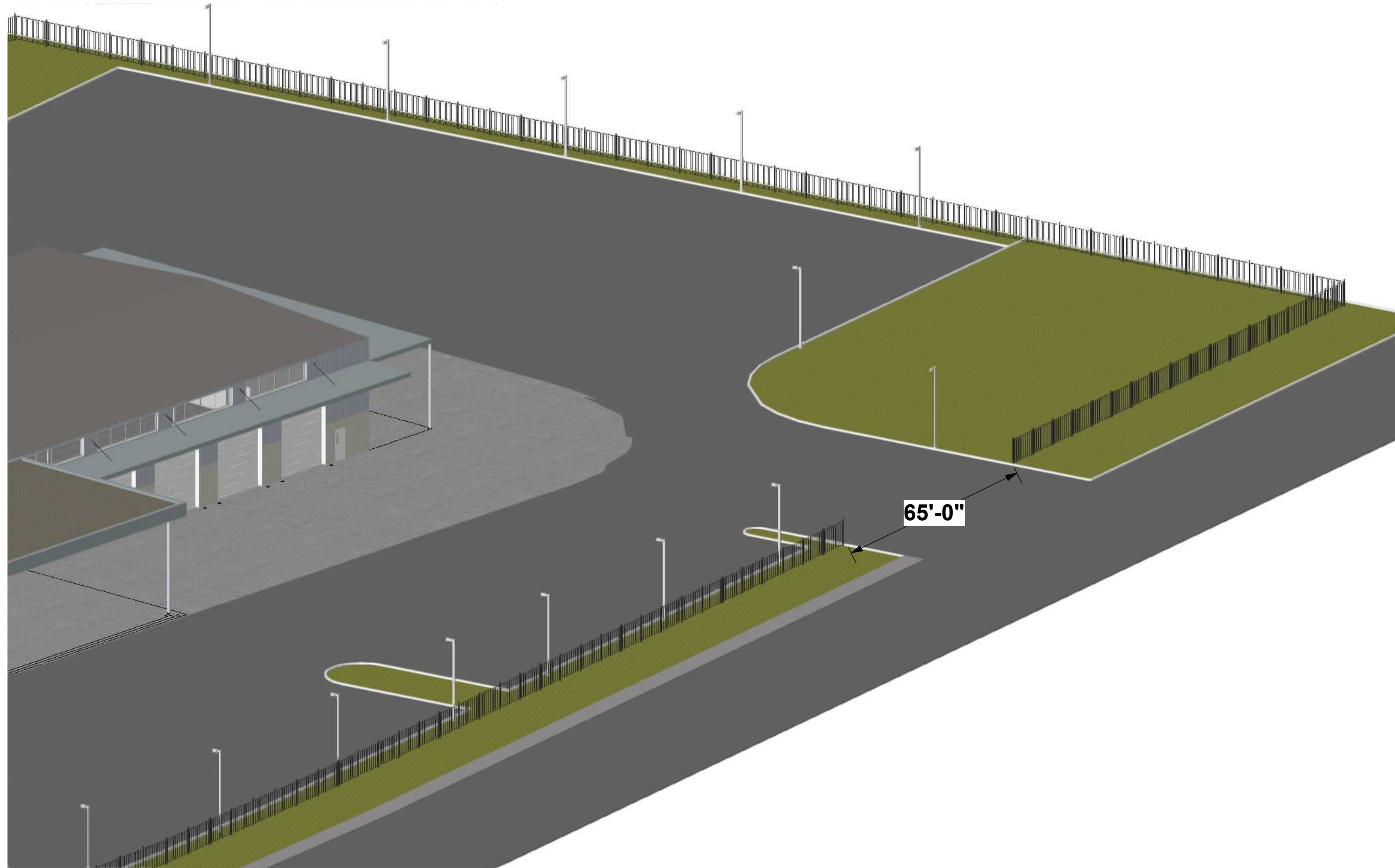
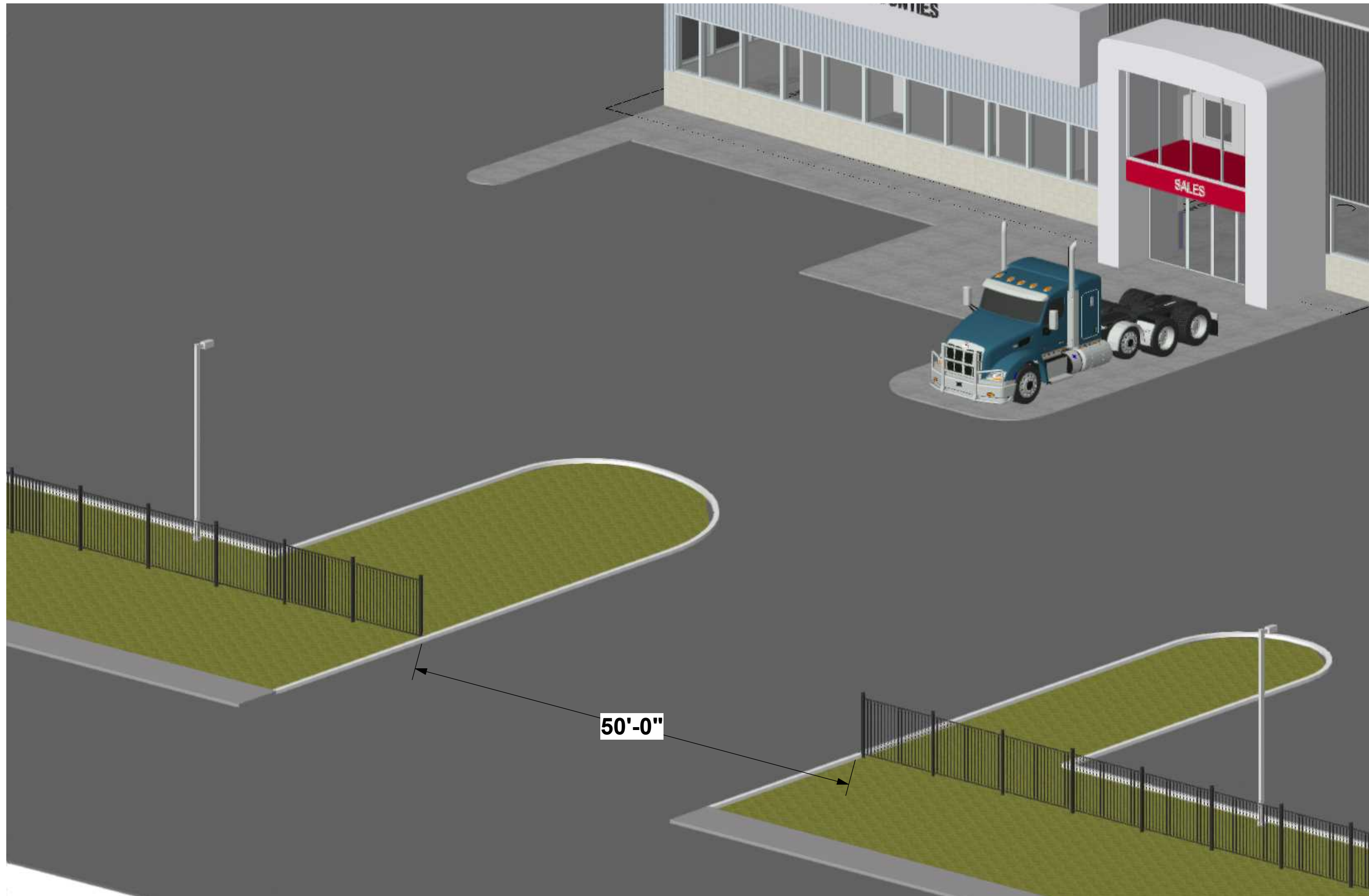

PROPOSED FENCE AT THEATRE DRIVE ENTRY

PROPOSED FENCE AT NUTWOOD CIRCLE ENTRY

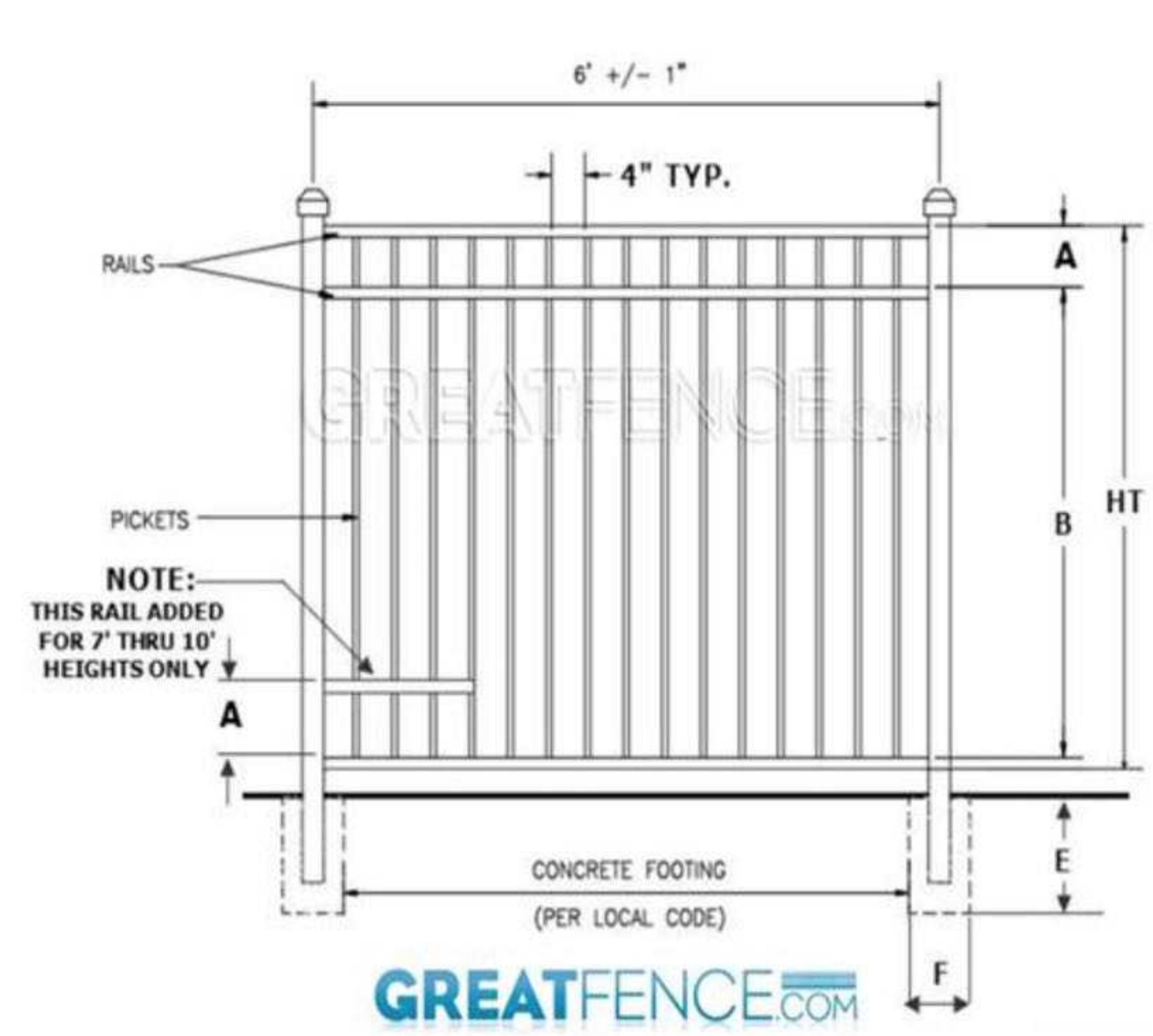

INDUSTRIAL STYLE 9 SPECIFICATIONS
 Horizontal Rails: 1 5/8" X 1 5/8"
 Side Walls: .100"
 Top Walls: .070"
 Internal: 8 Metal Support Ribs
 ADDING RINGS TO YOUR FENCE PANEL DECREASES 'A'
 Pickets: 1" x 1" x .062"
 Picket Spacing: 4"
 Powder Coat: 2604-5 AAMA
 Lifetime Warranty: No Rusting

DIMENSIONS				
HT	A	B	E	F
4'	7 5/8"	40 3/8"	PER LOCAL CODE	
5'	7 5/8"	52 3/8"	PER LOCAL CODE	
6'	7 5/8"	64 3/8"	PER LOCAL CODE	
7'	10 5/8"	73 3/8"	PER LOCAL CODE	
8'	10 5/8"	85 3/8"	PER LOCAL CODE	
9'	13 5/8"	94 3/8"	PER LOCAL CODE	
10'	13 5/8"	106 3/8"	PER LOCAL CODE	

PROPOSED FENCE SPEC

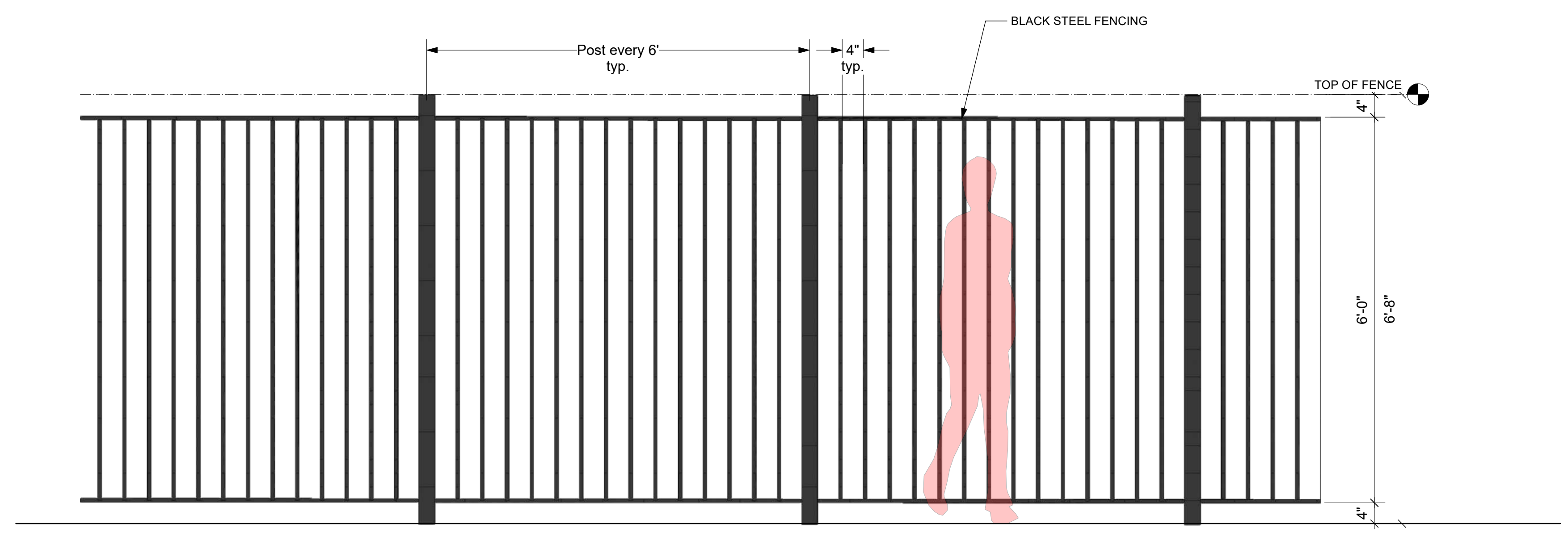

PROPOSED SITE FENCING
 SCALE: 3/4" = 1'-0"

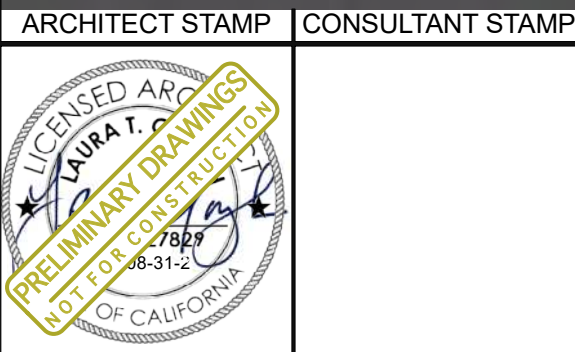

OWNER INFO
Craig Archer
3030 Ramada Drive, Paso Robles CA

Peterbilt Paso Robles

2805 Theatre Drive
Paso Robles, CA 93446
APN: 009-851-022

PROJECT DATA

DATE	ISSUE
03 JUN 22	DEVELOPMENT PLAN RESUBMITTAL

JOBNUMBER
2138

AGENCY APPROVAL

SHEET TITLE
SITE RENDERINGS

AS113

© 2022 Studio 2G Architects, LLP



VIEW FROM NORTHWEST CORNER OF SITE



VIEW FROM SOUTHWEST CORNER OF SITE



VIEW TOWARDS TRUCK DISPLAY FROM THEATRE DRIVE ENTRY



VIEW FROM THEATRE DRIVE ENTRY AT NIGHT

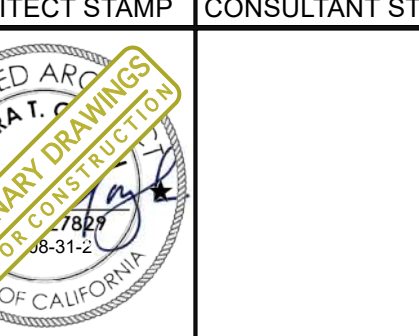

OWNER:
Craig Archer
3030 Ramada Drive, Paso Robles CA

Peterbilt Paso Robles
2805 Theatre Drive
Paso Robles, CA 93446
APN: 009-851-022

Symbol	Label	Quantity	Manufacturer	Catalog Number	Description	Lamp	Lumens Per Lamp	Light Loss Factor	Wattage	Notes
	S	1	LITHONIA	RSX2 LED P3 40K R4 MVOLT SPA NLTAIR2 PIRHN [FINISH]//SSS 21.5FT [THICKNESS] DM28AS [FINISH]	LED POLE MOUNTED AREA LUMINAIRE ON SQUARE STRAIGHT STEEL POLE	4000K LED	22020	0.92	299.96	ASSUMED 2.5FT CONCRETE BASE - PLEASE CONFIRM
	SL	5	LITHONIA	RSX2 LED P3 40K R4 MVOLT ASP HS NLTAIR2 PIRHN [FINISH]//SSS 21.5FT [THICKNESS] DM19AS [FINISH]	LED POLE MOUNTED AREA LUMINAIRE WITH TILTABLE ARM ON SQUARE STRAIGHT STEEL POLE	4000K LED	14473	0.92	149.98	ASSUMED 2.5FT CONCRETE BASE - PLEASE CONFIRM
	SL1	14	LITHONIA	RSX2 LED P3 40K AFR MVOLT SPA HS NLTAIR2 PIRHN [FINISH]//SSS 21.5FT [THICKNESS] DM19AS [FINISH]	LED POLE MOUNTED AREA LUMINAIRE ON SQUARE STRAIGHT STEEL POLE	4000K LED	16493	0.92	149.98	ASSUMED 2.5FT CONCRETE BASE - PLEASE CONFIRM
	SL2	30	LITHONIA	CNY LED P2 40K MVOLT	LED SURFACE MOUNTED CANOPY DOWNLIGHT	4000K LED	6601	0.92	51.86	
	SL3	2	LITHONIA	WDGE2 LED P2 40K 80CRI T3M MVOLT SRM [FINISH]	LED SURFACE MOUNTED WALL SCONCE	4000K LED	2062	0.92	18.9815	
	SL4	12	TARGETTI	KPL 41 WW L2 40 [TRIM RING] [INSTALLATION SLEEVE]	LED RECESSED INGRADE WALLWASHER	4000K LED	4665	0.92	35.7	

Description	Symbol	Avg	Max	Min	Max/Min	Avg/Min
CORNER DISPLAY AREA	+	12.1 fc	18.8 fc	2.1 fc	9.0:1	5.8:1
PAD AROUND BUILDING	+	3.0 fc	12.3 fc	0.3 fc	41.0:1	10.0:1
PARKING+DRIVE	+	2.5 fc	22.9 fc	0.0 fc	N/A	N/A
SERVICE CANOPY	+	14.0 fc	18.4 fc	6.4 fc	2.9:1	2.2:1

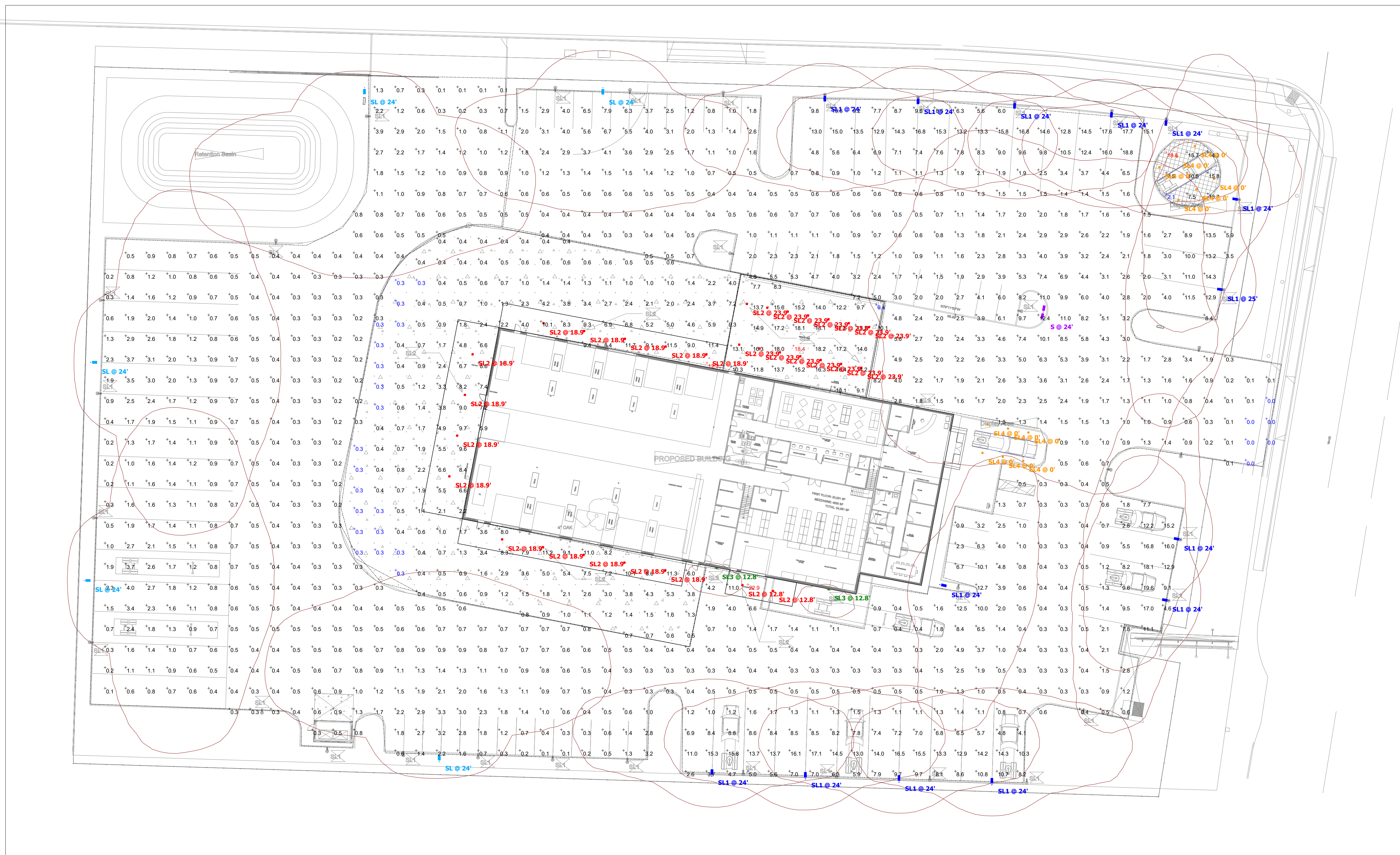

Plan View
Scale - 1" = 30ft

DISCLAIMER
The photometric calculation is provided as service for evaluating lighting levels and the results are based upon the data entered by the designer and the criteria provided by the customer. Responsibility of approval is by others. All of the data and fixture selections shall be reviewed and accepted by the approving authority. Fixture nomenclature shall be approved through submittal process prior to product being ordered.

DATE	ISSUE
03 JUN 22	DEVELOPMENT PLAN RESUBMITTAL

JOB NUMBER
2138

SITE LIGHTING PLAN

AS201



Length:	29.3" (74.4 cm)
Width:	13.4" (34.0 cm)
Height:	3.0" (7.6 cm) Main Body 7.2" (18.3 cm) Arm
Weight:	30.6 lbs (13.9 kg)

Series	Performance Package	Color Temperature ¹	Package	Finish	
RSX2 LED	P1	30K	3000	R2	Typ White
	P2	40K	4000K	R3	Typ White
	P3	50K	5000K	R5	Typ White
	P4	50K	5000K	R4	Typ White
	P5	50K	5000K	R5	Typ White
	P6	50K	5000K	R5	Typ White
	P7	50K	5000K	R5	Typ White

Series	Performance Package	Color Temperature ¹	Package	Finish	
RSX2 LED	P1	30K	3000	R2	Typ White
	P2	40K	4000K	R3	Typ White
	P3	50K	5000K	R5	Typ White
	P4	50K	5000K	R4	Typ White
	P5	50K	5000K	R5	Typ White
	P6	50K	5000K	R5	Typ White
	P7	50K	5000K	R5	Typ White

One Lithonia Way • Cary, NC 27513 • Phone: 1-800-705-SERV (7378) • Fax: 919-437-2122



Width:	10"
Height:	4.3"
Depth:	10"
Weight:	6.5lbs

Series	Performance Package	Color Temperature ¹	Package	Finish	
CNY LED	P0	3000	1000	DB	Black/White
	P1	4000	1000	DB	White
P2	5000	1000	DB	White	

INTENDED USE
CNY LED is intended for use in high-traffic areas such as retail, food service, and other commercial applications. It is not intended for use in residential applications.

CONSTRUCTION
CNY LED is constructed from high-quality materials to ensure long life and performance. The luminaire is designed to be easy to install and maintain.

WARRANTY
CNY LED is warranted for a period of 5 years from the date of installation. The warranty is limited to the luminaire and does not cover labor or other charges.

One Lithonia Way • Cary, NC 27513 • Phone: 1-800-705-SERV (7378) • Fax: 919-437-2122



Series	Performance Package	Color Temperature ¹	Package	Finish	
SSS	P1	30K	3000	R2	Typ White
	P2	40K	4000K	R3	Typ White
	P3	50K	5000K	R5	Typ White
	P4	50K	5000K	R4	Typ White
	P5	50K	5000K	R5	Typ White
	P6	50K	5000K	R5	Typ White
	P7	50K	5000K	R5	Typ White

Series	Performance Package	Color Temperature ¹	Package	Finish	
SSS	P1	30K	3000	R2	Typ White
	P2	40K	4000K	R3	Typ White
	P3	50K	5000K	R5	Typ White
	P4	50K	5000K	R4	Typ White
	P5	50K	5000K	R5	Typ White
	P6	50K	5000K	R5	Typ White
	P7	50K	5000K	R5	Typ White

One Lithonia Way • Cary, NC 27513 • Phone: 1-800-705-SERV (7378) • Fax: 919-437-2122



Length:	12"
Width:	12"
Height:	4"
Weight:	11.5 lbs

Series	Performance Package	Color Temperature ¹	Package	Finish	
KEPLERO	P1	30K	3000	R2	Typ White
	P2	40K	4000K	R3	Typ White
	P3	50K	5000K	R5	Typ White
	P4	50K	5000K	R4	Typ White
	P5	50K	5000K	R5	Typ White
	P6	50K	5000K	R5	Typ White
	P7	50K	5000K	R5	Typ White

One Targetti Way • Cary, NC 27513 • Phone: 1-800-705-SERV (7378) • Fax: 919-437-2122



Length:	12"
Width:	12"
Height:	4"
Weight:	11.5 lbs

Series	Performance Package	Color Temperature ¹	Package	Finish	
WDGE2 LED	P1	30K	3000	R2	Typ White
	P2	40K	4000K	R3	Typ White
	P3	50K	5000K	R5	Typ White
	P4	50K	5000K	R4	Typ White
	P5	50K	5000K	R5	Typ White
	P6	50K	5000K	R5	Typ White
	P7	50K	5000K	R5	Typ White

One Lithonia Way • Cary, NC 27513 • Phone: 1-800-705-SERV (7378) • Fax: 919-437-2122



Series	Performance Package	Color Temperature ¹	Package	Finish	
SSS	P1	30K	3000	R2	Typ White
	P2	40K	4000K	R3	Typ White
	P3	50K	5000K	R5	Typ White
	P4	50K	5000K	R4	Typ White
	P5	50K	5000K	R5	Typ White
	P6	50K	5000K	R5	Typ White
	P7	50K	5000K	R5	Typ White

Series	Performance Package	Color Temperature ¹	Package	Finish	
SSS	P1	30K	3000	R2	Typ White
	P2	40K	4000K	R3	Typ White
	P3	50K	5000K	R5	Typ White
	P4	50K	5000K	R4	Typ White
	P5	50K	5000K	R5	Typ White
	P6	50K	5000K	R5	Typ White
	P7	50K	5000K	R5	Typ White

INTENDED USE
SSS is intended for use in high-traffic areas such as retail, food service, and other commercial applications. It is not intended for use in residential applications.

CONSTRUCTION
SSS is constructed from high-quality materials to ensure long life and performance. The luminaire is designed to be easy to install and maintain.

WARRANTY
SSS is warranted for a period of 5 years from the date of installation. The warranty is limited to the luminaire and does not cover labor or other charges.

One Lithonia Way • Cary, NC 27513 • Phone: 1-800-705-SERV (7378) • Fax: 919-437-2122



Length:	12"
Width:	12"
Height:	4"
Weight:	11.5 lbs

Series	Performance Package	Color Temperature ¹	Package	Finish	
KEPLERO	P1	30K	3000	R2	Typ White
	P2	40K	4000K	R3	Typ White
	P3	50K	5000K	R5	Typ White
	P4	50K	5000K	R4	Typ White
	P5	50K	5000K	R5	Typ White
	P6	50K	5000K	R5	Typ White
	P7	50K	5000K	R5	Typ White

One Targetti Way • Cary, NC 27513 • Phone: 1-800-705-SERV (7378) • Fax: 919-437-2122



Length:	12"
Width:	12"
Height:	4"
Weight:	11.5 lbs

Series	Performance Package	Color Temperature ¹	Package	Finish	
WDGE2 LED	P1	30K	3000	R2	Typ White
	P2	40K	4000K	R3	Typ White
	P3	50K	5000K	R5	Typ White
	P4	50K	5000K	R4	Typ White
	P5	50K	5000K	R5	Typ White
	P6	50K	5000K	R5	Typ White
	P7	50K	5000K	R5	Typ White

One Lithonia Way • Cary, NC 27513 • Phone: 1-800-705-SERV (7378) • Fax: 919-437-2122

Attachment 9
studio
2G
Architects, LLP
811 Palm Street
San Jose, CA 95128
www.studio2g.com
P 805.594.0771
F 805.594.5137

ARCHITECT STAMP CONSULTANT STAMP
CRAIG ARCHER
3030 Ramada Drive, Paso Robles CA
APN: 009-851-022

PROJECT DATA
DATE: 03 JUN 22
ISSUE: DEVELOPMENT PLAN RESUBMITTAL

SUBMITTALS & REVISIONS
JOB NUMBER: 2138

AGENCY APPROVAL

PREP FILE

SITE LIGHTING PLAN

AS202

© 2020 BARRON ARCHITECT LLP

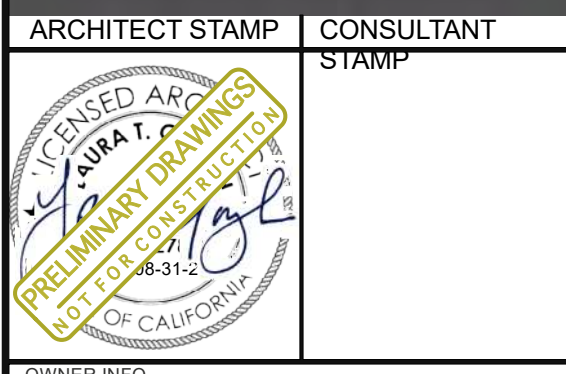
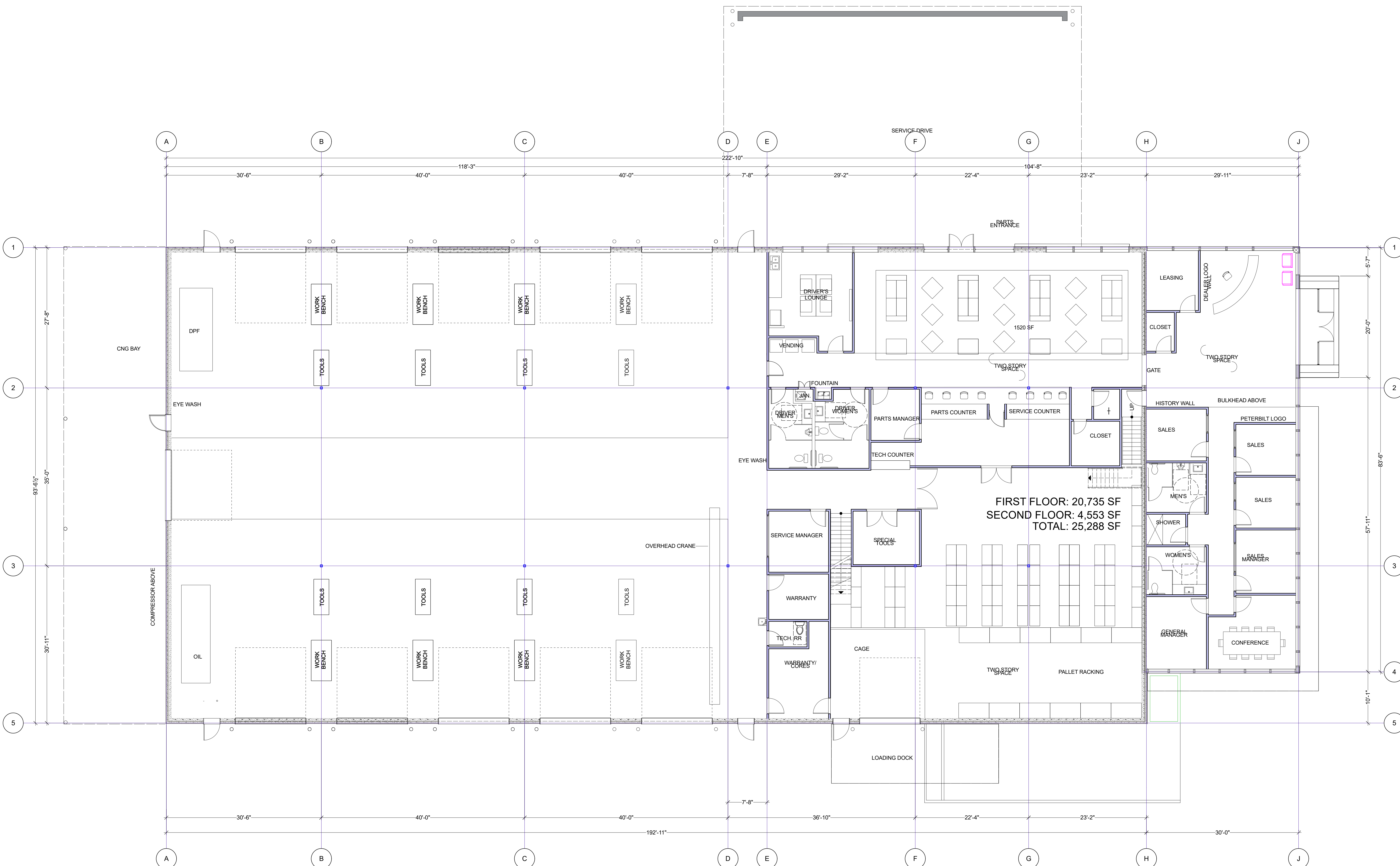

OWNER INFO
Craig Archer
 3030 Ramada Dr, Paso Robles, CA

Peterbilt Paso Robles
 2805 Theatre Drive
 Paso Robles, CA 93446
 APN: 009-851-022

SUBMITTALS & REVISIONS	
DATE	ISSUE
03 JUN 22	DEVELOPMENT PLAN RESUBMITTAL

JOB NUMBER
2138

AGENCY APPROVAL

SHEET TITLE
FIRST FLOOR DIMENSIONAL PLAN

A-101

GROUND FLOOR PLAN
 Scale: 1/8" = 1'-0"

ARCHITECT STAMP CONSULTANT STAMP

SEALED ARCHITECT'S STAMP
PRELIMINARY OR FINAL
BY THE ARCHITECT
DATE: 8-31-22
COUNTY OF CALIFORNIA

OWNER INFO
Craig Archer
3030 Ramada Dr, Paso Robles, CA

PROJECT DATA

Peterbilt Paso Robles

2805 Theatre Drive
Paso Robles, CA 93446
APN: 009-851-022

SUBMITTALS & REVISIONS

DATE	ISSUE
03 JUN 22	DEVELOPMENT PLAN RESUBMITTAL

JOB NUMBER
2138

AGENCY APPROVAL

SECOND FLOOR DIMENSIONAL PLAN

A-102

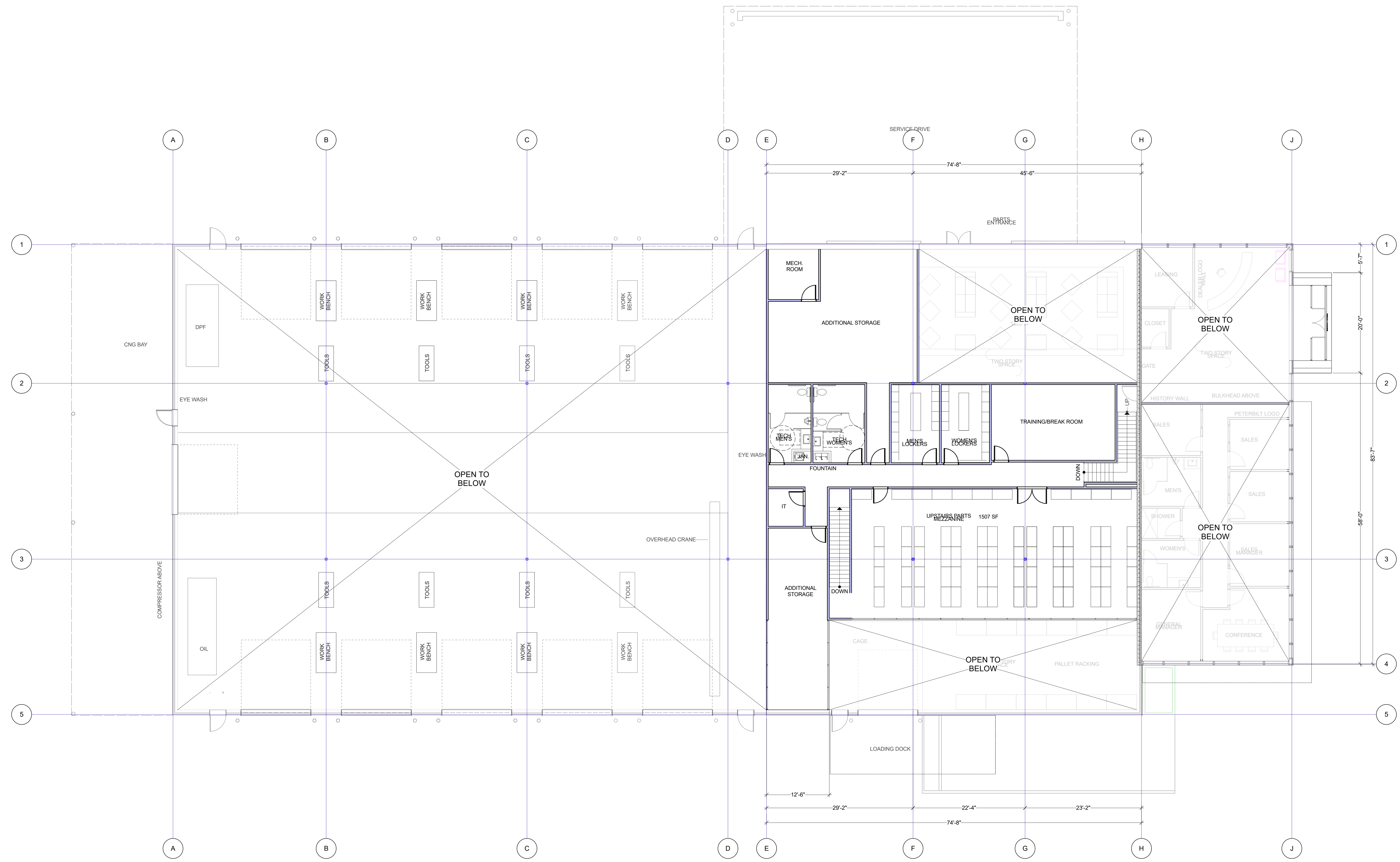

SECOND FLOOR PLAN
Scale: 1/8" = 1'-0"

PASO ROBLES SIGN - 10' x 30'

2805 THEATER DRIVE

PASO ROBLES, CA., 93446

DRAWING ORGANIZATION

THE ORGANIZATION OF THESE DRAWINGS IS NOT INTENDED TO CONTROL THE DIVISION OF WORK AMONG SUBCONTRACTORS. IT SHALL BE THE GENERAL CONTRACTOR'S RESPONSIBILITY TO DIVIDE THE WORK.

COPIES OF THESE DRAWINGS ARE SUPPLIED TO THE OWNER, THE CONTRACTOR AND OTHERS FOR USE ON THIS PARTICULAR PROJECT. ALL DRAWINGS, SPECIFICATIONS AND COPIES OF SUCH PREPARED BY ASSOCIATED DESIGN AND ENGINEERING, INC. ARE THE PROPERTY OF ASSOCIATED DESIGN AND ENGINEERING, INC. THE DRAWINGS ARE NOT TO BE REPRODUCED, CHANGED, OR COPIED IN ANY WAY, NOR ARE THEY TO BE ASSIGNED TO A THIRD PARTY WITHOUT FIRST OBTAINING THE WRITTEN PERMISSION OF ASSOCIATED DESIGN AND ENGINEERING, INC.

IT IS THE INTENT OF THE PLANS AND SPECIFICATIONS TO COVER ALL THINGS REQUIRED TO MAKE COMPLETE AND OPERATIVE SYSTEMS. CONTRACTOR IS TO FURNISH ALL LABOR, MATERIALS, TRANSPORTATION, EQUIPMENT, AND ALL OTHER MISCELLANEOUS SERVICES REQUIRED TO COMPLETE THE PROJECT. ANYTHING WHICH MAY BE REASONABLY CONSIDERED AS A NECESSARY PART OF THE PROJECT IS TO BE INCLUDED WHETHER SPECIFICALLY SHOWN, MENTIONED OR NOT. THE ARCHITECT WILL GIVE ANY INTERPRETATIONS NECESSARY FOR THE CONTRACTOR TO PROPERLY ESTIMATE THE PROJECT.

CONTRACTOR'S STATEMENT OF RESPONSIBILITY

THE DESIGN/BUILD CONTRACTORS SHALL BE FULLY AND SOLELY RESPONSIBLE AND LIABLE FOR ALL DESIGN, ENGINEERING AND CONSTRUCTION FOR HIS/HERS PHASE OF THE WORK AS INDICATED ON THESE DOCUMENTS. BY THE ACT OF COMMENCING WORK ON THIS PROJECT OR BY THEIR SIGNATURES ON DRAWINGS INCLUDED HEREIN OR TO BE SUBMITTED SEPARATELY FOR THIS PROJECT, EACH CONTRACTOR HAS DIRECT, COMPLETE AND ASSUMED FULL RESPONSIBILITY FOR THE DESIGN, ENGINEERING AND CONSTRUCTION OF HIS WORK INCLUDING, BUT NOT LIMITED TO ACCURACY, COMPLETENESS AND COMPLIANCE WITH ALL APPLICABLE CODES AND ORDINANCES AND THE REQUIREMENTS OF THE OWNER AND/OR TENANT.

CONTRACTOR SHALL BE RESPONSIBLE FOR OBTAINING AND PAYING FOR THE COST OF ALL INSPECTIONS AND TESTS INDICATED ON THE PLANS AND SPECIFICATIONS, RECOMMENDED BY THE SOILS REPORT AND/OR REQUIRED BY ANY GOVERNING AGENCY. CONTRACTOR SHALL PROVIDE PROTECTION AS NECESSARY PER CITY AND LOCAL CODE REQUIREMENTS. CONTRACTOR SHALL PROVIDE FIRE EXTINGUISHERS AND ANY REQUIRED SIGNAGE AS DIRECTED BY THE LOCAL FIRE DEPARTMENT.

IT IS THE CONTRACTOR'S RESPONSIBILITY TO VERIFY ALL FIELD MEASUREMENTS AND CONDITIONS FOR CONFORMANCE WITH THE PLANS SHOULD THE CONTRACTOR FIND ANY ERRORS, OMISSIONS OR DISCREPANCIES IN THE PLANS WITH RESPECT TO THE FIELD OBSERVATIONS OR OTHER PARTS OF THE PLANS. THE ERRORS, OMISSIONS OR DISCREPANCIES SHALL BE BROUGHT TO THE ATTENTION OF THE PROJECT ARCHITECT. THE CONTRACTOR AND ARCHITECT SHALL RESOLVE ALL ERRORS, OMISSIONS AND DISCREPANCIES BEFORE COMMENCING THAT PORTION OF THE WORK. DIMENSIONS GOVERN ANY DISCREPANCIES THAT CHANGE TO THE PLANS SHALL REQUIRE THE APPROVAL OF THE OWNER AND PROJECT ARCHITECT.

CODES, RULES, AND REGULATION

ALL WORK AND MATERIAL SHALL BE PERFORMED AND INSTALLED IN COMPLIANCE WITH THE FOLLOWING CODES AS ADOPTED AND AMENDED BY THE LOCAL GOVERNING AGENCIES. NOTHING IN THESE PLANS IS TO BE CONSTRUED TO PERMIT WORK NOT CONFORMING TO THESE CODES:

- 2022 CALIFORNIA ADMINISTRATIVE CODE (CAC)
- 2022 CALIFORNIA BUILDING CODE (CBC)
- 2022 CALIFORNIA ELECTRIC CODE (CEC)
- 2022 CALIFORNIA ENERGY CODE (CEC)
- 2022 CALIFORNIA FIRE CODE (FC)
- SAFETY ORDERS, STATE DIVISION OF INDUSTRIAL SAFETY TITLE 24 AND 25 CALIFORNIA
- CITY ORDINANCES AND REGULATIONS
- APPLICABLE SECTIONS OF THE CALIFORNIA ENERGY STANDARDS SERVING UTILITY COMPANIES

NOTE: WHERE WORK OF A HIGHER DEGREE IS INDICATED ON THE PLANS OR IN THE SPECIFICATIONS, THIS REQUIREMENT SHALL GOVERN.

GENERAL NOTES:

1. EACH SUBCONTRACTOR SHALL VISIT THE SITE AND INSPECT THE PREMISES TO BE IMPROVED AND SHALL VERIFY THE WORK TO BE DONE, THE EXISTING CONDITIONS, AND SHALL NOTIFY THE GENERAL CONTRACTOR OF ANY AND ALL DISCREPANCIES PRIOR TO SUBMITTING BID AND STARTING OF ANY WORK. GENERAL CONTRACTOR SHALL NOTIFY THE OWNER OF ANY AND ALL DISCREPANCIES PRIOR TO SUBMITTING BID AND STARTING OF ANY WORK.
2. ALL WORK SHALL BE DONE IN THE BEST WORKMANLIKE MANNER AND MUST BE DONE IN ACCORDANCE WITH THE REQUIREMENTS OF ALL LOCAL GOVERNING AGENCIES. FURTHERMORE, ALL WORK SHALL MEET WITH THE APPROVAL OF THE OWNER.
3. WRITTEN DIMENSIONS ON THESE DRAWINGS SHALL HAVE PRECEDENCE OVER SCALED DIMENSIONS. CONTRACTORS SHALL VERIFY AND BE RESPONSIBLE FOR ALL DIMENSIONS ON THE JOB AND CONDITIONS ON THE JOB. ANY VARIATIONS FROM THE DIMENSIONS SHOWN BY THESE DRAWINGS SHALL BE REVIEWED BY ASSOCIATED DESIGN & ENGINEERING, INC. BEFORE PROCEEDING WITH FABRICATION.
4. THIS SET OF DRAWINGS, DESIGN AND/OR SPECIFICATION ARE THE EXCLUSIVE PROPERTY OF ASSOCIATED DESIGN & ENGINEERING, INC. ITS ACCEPTANCE CONSTITUTES AN AGREEMENT THAT IT SHOULD BE TREATED AS A STRICTLY CONFIDENTIAL DOCUMENT TO BE USED FOR NOT PURPOSE OTHER THAN TO AID IN THE ASSEMBLY, CONSTRUCTION OR OPERATION OF THE UNITS OR SYSTEMS SHOWN FOR THIS SPECIFIC PROJECT ONLY OR AS OTHERWISE EXPRESSLY AUTHORIZED IN WRITING BY ASSOCIATED DESIGN & ENGINEERING, INC. THAT IT IS TO BE RETURNED UPON REQUEST AND IS NOT TO BE COMMUNICATED, DISCLOSED, OR COPIED, EXCEPT AS EXPRESSLY AUTHORIZED IN WRITING BY ASSOCIATED DESIGN & ENGINEERING, INC. ASSOCIATED DESIGN & ENGINEERING, INC. EXPRESSLY RESERVES ITS COMMON LAW COPYRIGHT AND OTHER PROPERTY RIGHTS IN THESE PLANS. THESE PLANS ARE NOT TO BE REPRODUCED, CHANGED, OR COPIED IN ANY MANNER WHATSOEVER, NOR ARE THEY TO BE ASSIGNED TO A THIRD PARTY WITHOUT FIRST OBTAINING THE WRITTEN PERMISSION AND CONSENT OF ASSOCIATED DESIGN & ENGINEERING, INC. IN THE EVENT OF UNAUTHORIZED REUSE OF THESE PLANS BY A THIRD PARTY, THE THIRD PARTY SHALL HOLD ASSOCIATED DESIGN & ENGINEERING, INC. HARMLESS AND SHALL BEAR THE FINANCIAL RESPONSIBILITY OF ASSOCIATED DESIGN'S LEGAL COSTS.
5. A JOB CARD IS REQUIRED TO BE VISIBLE FROM THE STREET, IT IS UNDERSTOOD THAT IF NO JOB CARD IS OBSERVED NO INSPECTION WILL TAKE PLACE.
6. THIS PERMIT DOES NOT INCLUDE ANY HIGH PILE STORAGE OR RACK STORAGE OVER 4 FEET HIGH, ANY SUCH PROPOSED STORAGE WILL REQUIRE PLANS SUBMITTED FOR REVIEW AND APPROVAL AND ISSUANCE OF PERMITS (2022 CFC CHAPTER 32)
7. ALL MATERIALS, EQUIPMENT AND SYSTEMS CALLED FOR ON PLANS AND IN THESE SPECIFICATIONS SHALL BE INSTALLED IN STRICT COMPLIANCE WITH THE MANUFACTURER'S LATEST SPECIFICATIONS.
8. CONTRACTORS SHALL MAINTAIN THE PREMISES IN A CLEAN AND ORDERLY CONDITION AND SHALL REMOVE ALL UNUSED MATERIALS AND DEBRIS, AND LEAVE PREMISES IN A CLEAN CONDITION.
9. ANY SUBSTITUTIONS TO THE MATERIALS AND/OR EQUIPMENT SPECIFIED MUST BE APPROVED BY THE OWNER. CONTRACTOR SHALL SUBMIT REQUEST FOR SUBSTITUTIONS AT THE TIME OF BID SUBMISSION. PRIOR TO START OF CONSTRUCTION THE GENERAL CONTRACTOR SHALL FAMILIARIZE HIMSELF WITH THE PLANS AND SPECIFICATIONS.
10. ANY DISCREPANCIES OR ERRORS SHALL BE CALLED TO THE ATTENTION OF THE ARCHITECT FOR CORRECTIONS BEFORE THE WORK EFFECTED THEREBY IS BIDDING OR EXECUTED. ALL WORK SHALL COMPLY IN EVERY RESPECT WITH CURRENT GOVERNING LAWS, UNIFORM BUILDING CODE AND ORDINANCES. ALL AGENCIES AND UTILITY COMPANIES SHALL BE GIVEN NECESSARY NOTICES RELATING TO THE WORK. CONTRACTOR SHALL OBTAIN AND PAY FOR ANY PERMITS OR NOTICES. ALL TESTING AND INSPECTION SERVICES SHALL BE PAID DIRECTLY BY THE OWNER.
11. SANITARY TOILET IS REQUIRED ON-SITE DURING CONSTRUCTION. (2022 CBC 3305.1)
12. PORTABLE FIRE EXTINGUISHERS SHALL COMPLY WITH (2022 CBC 906 AND THE 2022 CFC 904)
13. REPAIR ALL DAMAGED AND/OR OFF-GRADE CONCRETE STREET IMPROVEMENTS AS DETERMINED BY THE CONSTRUCTION MANAGED ENGINEER PRIOR TO OCCUPANCY
14. ANY SURVEY MONUMENTS WITHIN THE AREA OF CONSTRUCTION SHALL BE PRESERVED OR RESET BY A PERSON LICENSED TO PRACTICE LAND SURVEYING IN THE STATE OF CALIFORNIA
15. HIGH STRENGTH BOLTING, EPOXY ANCHORS BOLTS, SHOP AND FIELD WELDING MUST BE INSPECTED BY APPROVED INDEPENDENT INSPECTOR WHO SHALL BE RETAINED BY THE OWNER. INSPECTORS SHALL SUBMIT THEIR REPORTS DIRECTLY TO FRESNO COUNTY DEVELOPMENT SERVICES DIVISION. INSPECTIONS FOR THIS PROJECT WILL BE PROVIDED BY:

WORKING DAYS BEFORE COMMENCING EXCAVATION OPERATIONS WITHIN THE STREET RIGHT-OF-WAY AND/OR UTILITY EASEMENTS. ALL EXISTING UNDERGROUND FACILITIES SHALL HAVE BEEN LOCATED BY UNDERGROUND SERVICES ALERT (USA). CALL 1-800-42-2444

City: _____ State: Zp
 File: _____
 Plot: _____
 Web: _____

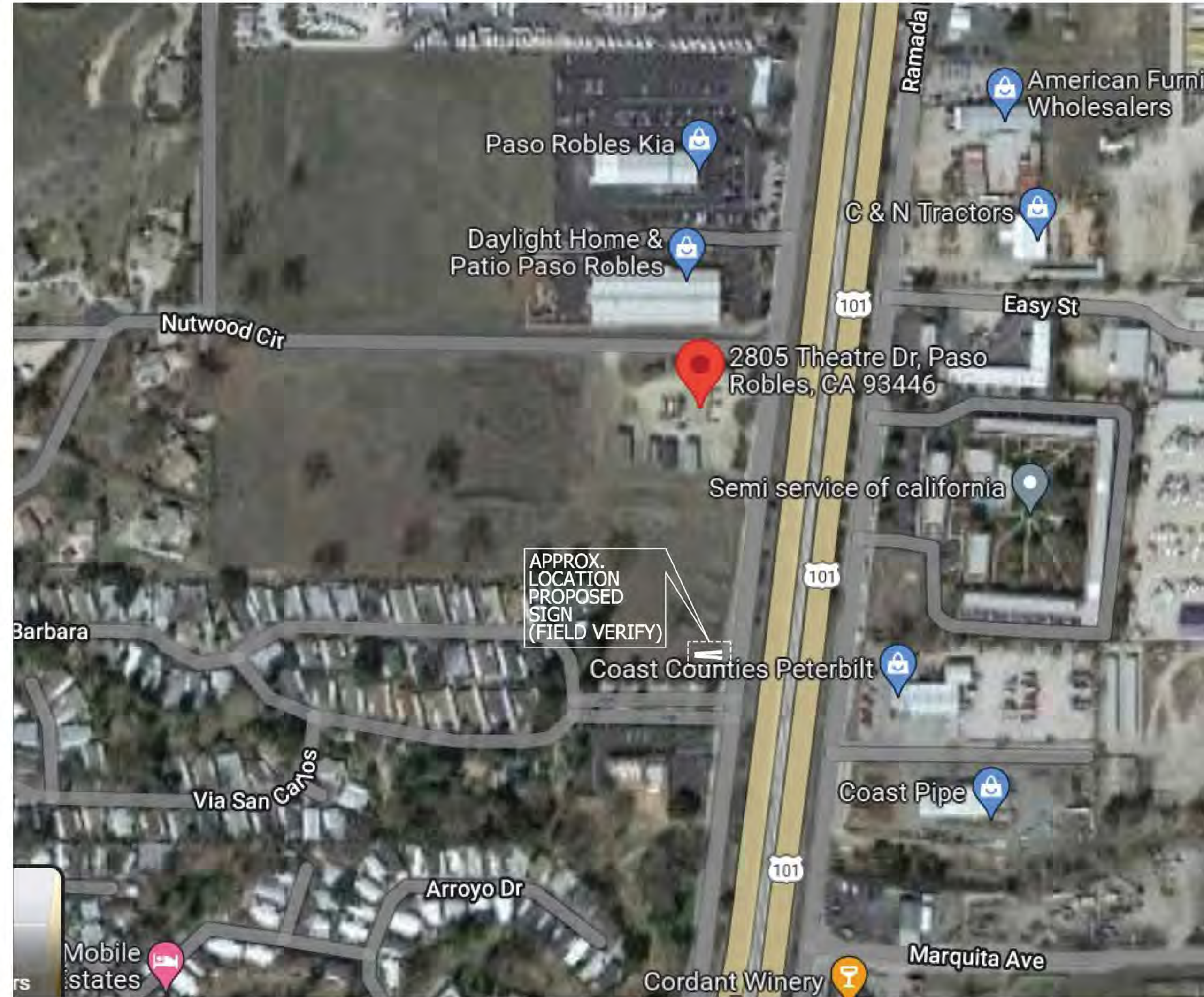

AERIAL VIEW ↑



SCOPE OF WORK

INSTALLATION OF NEW 10' X 30' DIGITAL BILLBOARD

SHEET INDEX

CI-1	COVER SHEET
CI-2	SITE PLAN
SI-1	SIGN DRAWINGS
SD-1	STRUCTURAL DETAILS
SD-2	STRUCTURAL DETAILS
E-1	ELECTRICAL SINGLE LINE DIAGRAM
E-2	ELECTRICAL SITE PLAN
E-3	ENERGY FORMS
E-4	ENERGY FORMS

DRAFT

CODE ANALYSIS

CONSTRUCTION TYPE	: 2N
OCCUPANCY CLASSIFICATION	: N/A
OCCUPANCY LOAD FACTOR	: N/A
2 EXITS REQUIRED IF ROOM OCCUPANT LOAD IS OVER	
OCCUPANT LOAD	: N/A
EXIT WIDTH REQUIRED (1.3X OCCUPANT LOAD AT STAIRS)	: N/A
(1.2X OCCUPANT LOAD TYP. EGRESS)	: N/A
OCCUPANCY SEPARATION	: N/A
FIRE RATING OF BUILDING ELEMENTS	
DRAFT STOPS	: N/A

LOCATION ON PROPERTY (PROTECTED OPENINGS)	: NOT REQUIRED
ALLOWABLE AREA	: 672 SQ. FT.
ALLOWABLE HEIGHT	: 40 FEET FROM FINISH GRADE
FLAME SPREAD CLASSIFICATION	: CLASS 2
MAXIMUM FLAME SPREAD CLASS	: 26-75
MAXIMUM TRAVEL DISTANCE FOR TYPICAL OCCUPANCY 200' IF FIRE SPRINKLERS 250'	: N/A

PROJECT TEAM

OWNER OUTFRONT MEDIA INCORPORATED 5618 E. SHIELDS AVE. FRESNO, CA 93721 PHONE: (559) 292-8300 CONTACT: ARYNN RAMAGE	SOILS ENGINEER KRAZANIASSOC., INC. GEOTECHNICAL ENGINEERING DIV. 215 W. DAKOTA AVE. CLOVIS, CA, 93602 PHONE: (559) 348-2200 CONTACT: DAVID JOROSZ/ STEVE NELSON PROJ#012-21285 DATE 1-1-2022
ARCHITECT ASSOCIATED DESIGN AND ENGINEERING, INC. 351 W. CROMWELL #108 FRESNO, CA 93711 PHONE: (559) 431-2389 FAX: (559) 431-5200 CONTACT: ARMEN DEVEJIAN	CIVIL ENGINEER LORE ENGINEERING INC. 420 DEWITT AVE. #101 CLOVIS, CA., 93602 PHONE: (559) 291-5200 FAX: (559) 291-5205
STRUCTURAL ENGINEER ASSOCIATED DESIGN AND ENGINEERING, INC. 351 W. CROMWELL #108 FRESNO, CA 93711 PHONE: (559) 431-2389 FAX: (559) 431-2014 CONTACT: MICHAEL JUNDT, SE	
GENERAL CONTRACTOR - (TO BE DETERMINED) NAME: ADDRESS: CITY, STATE, ZIP: PHONE: FAX: CONTACT:	

Attachment 9
 MICHAEL D. JUNDT S.E. 53336
 TERRY MOORE P.E. 5812
 ARMEN DEVEJIAN C26613
 PASO ROBLES SIGN - 10' X 30'
 architecture
 engineering
 forensic sciences
PASO ROBLES SIGN - 10' X 30'
ASSOCIATED DESIGN AND ENGINEERING INC.
 351 WEST CROMWELL AVE. SUITE 108 ■ FRESNO, CA 93711 ■ OFFICE: 559.431.2389 ■ FAX: 559.431.2074 ■ office@adeinc.biz ■ http://adeinc.biz



REVISIONS	
△	
△	
△	
△	
△	
△	
△	
SHEET	C1-1
JOB NO.	E23002
DATE	3/27/2023

F:\Engineering\2023\E23002 Outfront Paso Robles Peterbilt 51e\E23002.dwg 3/21/2023 11:46 AM BY CARLOS

MICHAEL D. JUNDT S.E. S9336
 TERRY MOORE P.E. S812
 ARMEN DEVEJIAN C26613

ARCHITECTURE
 engineering
 forensic sciences

ASSOCIATED DESIGN AND ENGINEERING INC.
 351 WEST CROWWELL AVE. SUITE 108
 FRESNO, CA 93711
 OFFICE: 559.431.2389
 FAX: 559.431.2074
 office@adecinc.biz
 http://adecinc.biz

PASO ROBLES SIGN - 10' X 30'



ASSOCIATED DESIGN AND ENGINEERING INC.

351 WEST CROWWELL AVE. SUITE 108
 FRESNO, CA 93711
 OFFICE: 559.431.2389
 FAX: 559.431.2074
 office@adecinc.biz
 http://adecinc.biz



REVISIONS	
Δ I.R. REVISION	08/30/22

SHEET	S1-1
JOB NO.	E23002
DATE	3/27/2023

DRAFT

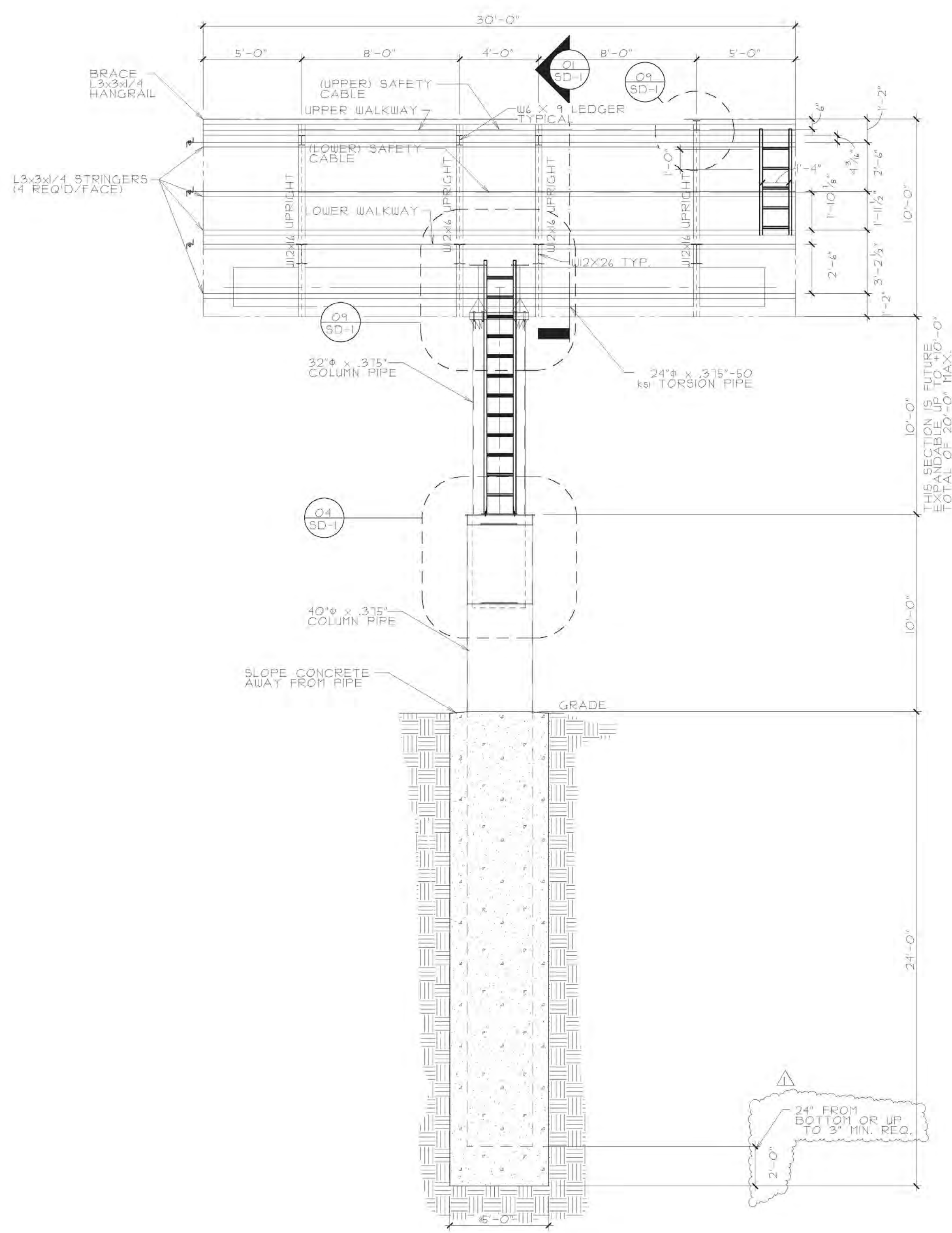

SOUTH/NORTH ELEVATION (FULL SIGN)

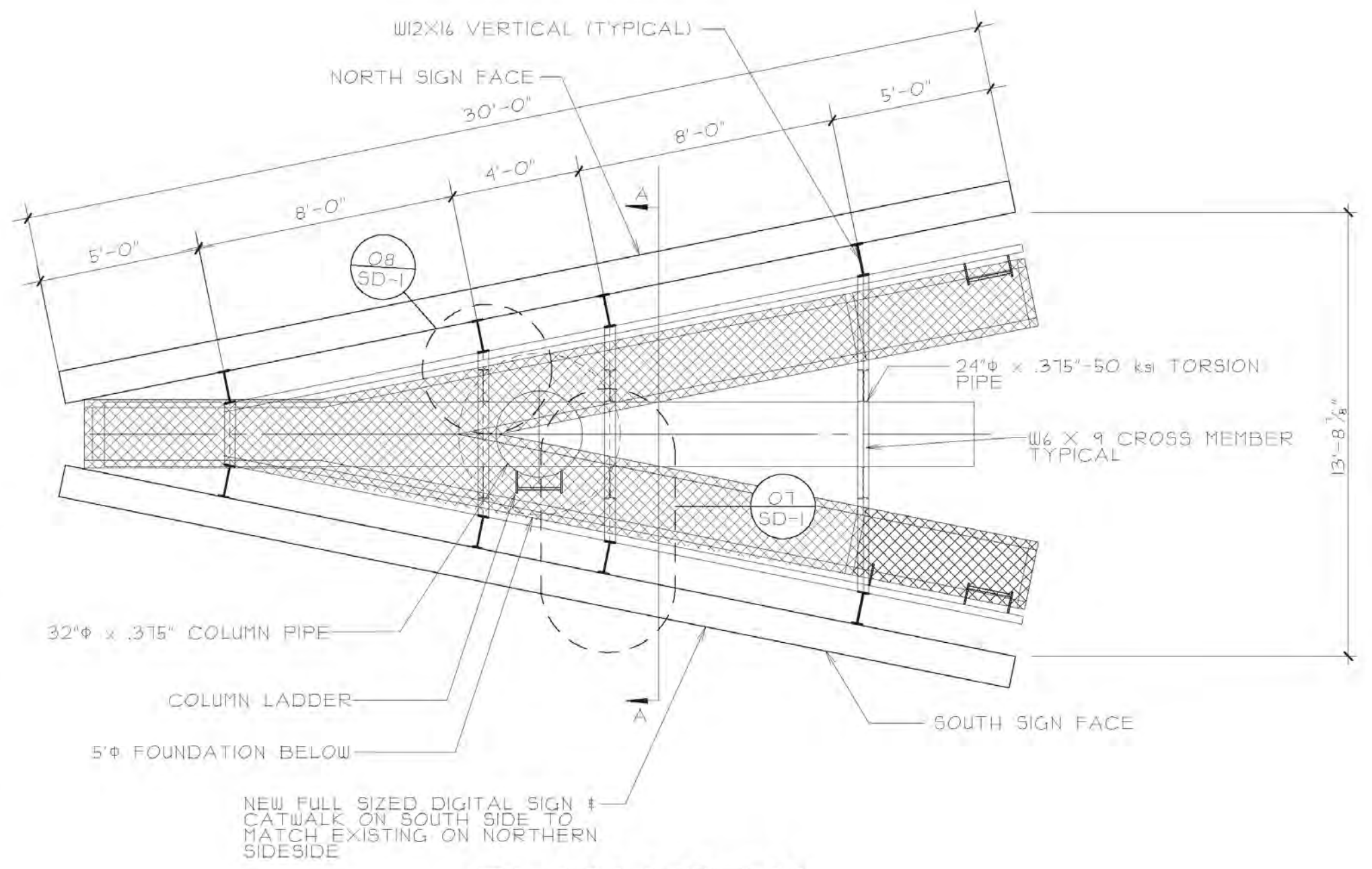

PLAN VIEW

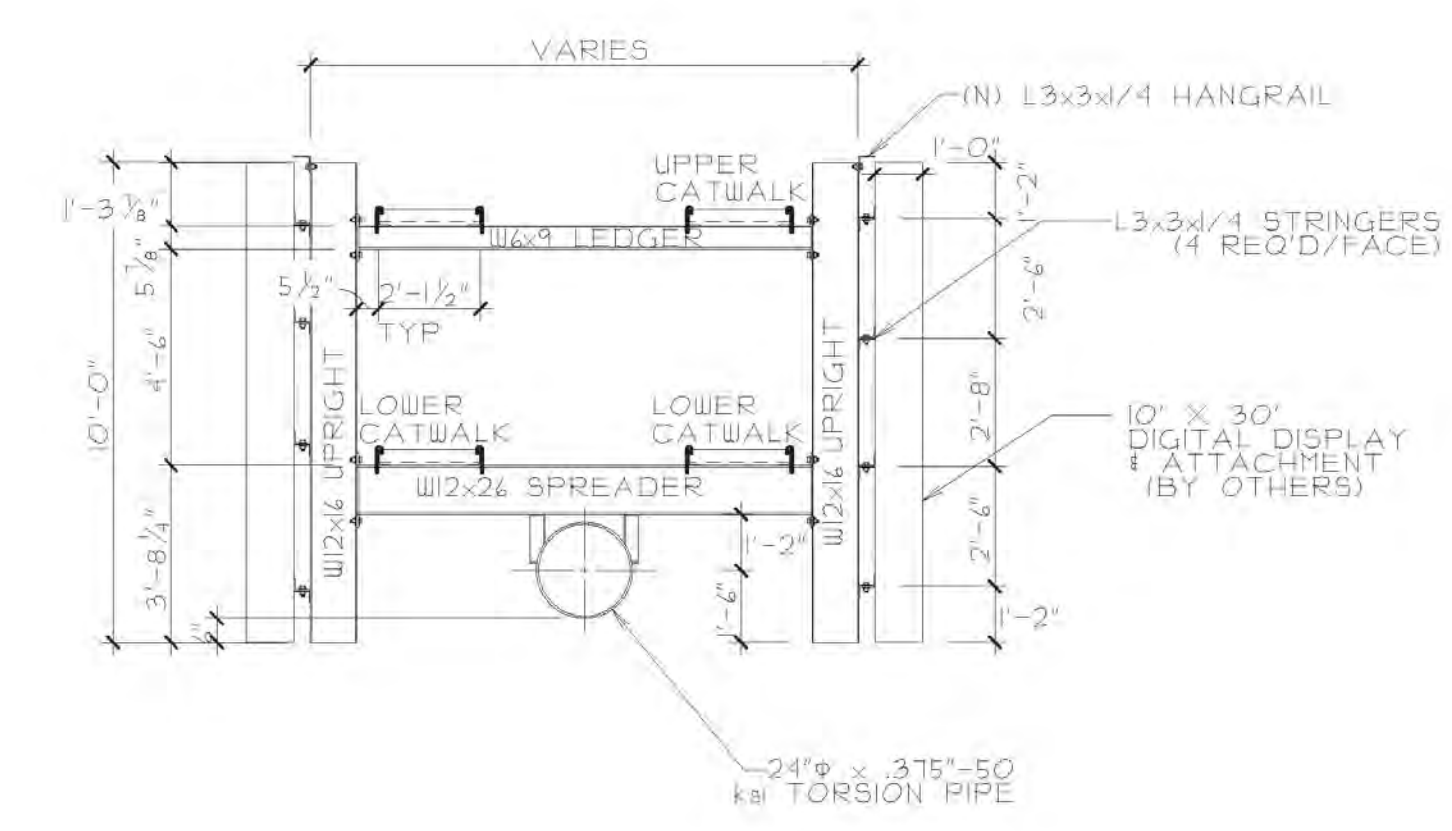

SECTION A-A

SEE DETAIL 01 SHEET SD-1

DEFERRED SUBMITTALS

- DEFERRED SUBMITTALS ARE THOSE PORTIONS OF THE DESIGN WHICH ARE NOT SUBMITTED AT THE TIME OF PERMIT APPLICATION AND WHICH ARE TO BE SUBMITTED TO THE PERMITTING AGENCY FOR ACCEPTANCE PRIOR TO INSTALLATION OF THAT PORTION OF THE WORK OR ARE REQUIRED TO BE SUBMITTED FOR REVIEW ONLY BY THE ENGINEER.
- WHERE DEFERRED SUBMITTALS INCLUDE ADDITIONAL MATERIALS, INSTALLATION, ANCHORAGE, OR CERTIFICATION OF COMPONENTS THAT REQUIRE SPECIAL INSPECTION AND/OR STRUCTURAL OBSERVATION TO MEET CODE REQUIREMENTS, THE DEFERRED SUBMITTAL SHALL INCLUDE SPECIFIC LINE ITEMS TO BE ADDED TO THE APPROPRIATE TABLES IN THE PROJECT'S STATEMENT OF SPECIAL INSPECTIONS PLAN IF THEY ARE NOT ALREADY IDENTIFIED.
- THE FOLLOWING IS A LIST OF DEFERRED SUBMITTALS THAT ARE EXPECTED TO CONTAIN STRUCTURAL CALCULATIONS OR SAFETY RELATED SYSTEM INFORMATION FOR REVIEW TO MEET BUILDING PERMITTING REQUIREMENTS FOR DESIGNED SYSTEMS. PRIOR TO INSTALLATION OF THE INDICATED STRUCTURAL ELEMENT, EQUIPMENT, DISTRIBUTION SYSTEM, OR COMPONENT OR ITS ANCHORAGE, THE CONTRACTOR SHALL SUBMIT THE REQUIRED CALCULATIONS AND SUPPORTING DATA AND DRAWINGS FOR REVIEW AND ACCEPTANCE BY THE ENGINEER.
 - DIGITAL PANEL ATTACHMENT METHOD
 - DIGITAL PANEL FRAMING

NOTE: ALL WELDING SHALL BE PERFORMED BY AN AWS CERTIFIED WELDER. SUBMIT CERTIFICATE TO THE BUILDING INSPECTOR.

BIOLOGICAL RESOURCES ASSESSMENT REPORT

PASO ROBLES PETERBILT PROJECT
2805 THEATRE DRIVE
PASO ROBLES, CALIFORNIA

Project No. 2202-1101

Prepared for:

Craig Archer
Coast Counties Peterbilt
1740 4th Street
San Jose, California 95112

Prepared by:

Padre Associates, Inc.
369 Pacific Street
San Luis Obispo, California 93401

APRIL 2022



Authenticity and Signature Page



**Padre Associates, Inc.
369 Pacific Street
San Luis Obispo, California 93401**

Padre Associates, Inc. hereby certifies that all statements furnished in the following Biological Resources Assessment Report and all supporting information acquired for this biological assessment are true and correct to the best of our knowledge and belief. Further, we certify that the field survey associated with this report was performed by Padre and that the report accurately represents all information retained from the field visit.

Christina Santala
Project Biologist

Shannon Gonzalez
Project Biologist

Alyssa Berry
Senior Biologist

TABLE OF CONTENTS

1.0 INTRODUCTION 1-1

2.0 REGULATORY FRAMEWORK 2-1

 2.1 FEDERAL REGULATIONS 2-1

 2.1.1 Endangered Species Act of 1972 2-1

 2.1.2 Migratory Bird Treaty Act 2-1

 2.2 STATE REGULATIONS 2-2

 2.2.1 California Fish and Game Code 2-2

 2.3 LOCAL REGULATIONS 2-2

3.0 METHODS 3-1

 3.1 DESKTOP REVIEW 3-1

 3.2 FIELD SURVEYS 3-1

4.0 FINDINGS 4-1

 4.1 ENVIRONMENTAL SETTING 4-1

 4.2 BIOLOGICAL RESOURCES 4-1

 4.2.1 Botanical 4-1

 4.2.2 Wildlife 4-2

 4.2.3 Aquatic Resources 4-2

 4.3 SPECIAL-STATUS BIOLOGICAL RESOURCES 4-2

 4.3.1 Special-Status Habitats 4-6

 4.3.2 Special-Status Botanical 4-6

 4.3.3 Special-Status Wildlife 4-7

5.0 POTENTIAL IMPACTS 5-1

6.0 RECOMMENDED MITIGATION MEASURES 6-1

7.0 REFERENCES 7-1

LIST OF FIGURES

Figure 1-1. Project Location 1-2

Figure 4-1. Biological Assessment Survey Results 4-4

Figure 4-2. Regional Special-Status Biological Resources 4-5

APPENDICES

Appendix A Site Photographs

Appendix B Vascular Plant List

Appendix C Wildlife List

Appendix D CNDDDB Results

1.0 INTRODUCTION

Padre Associates, Inc. (Padre) has prepared this Biological Resources Assessment Report (Report) on behalf of Craig Archer of Coast Counties Peterbilt (Client) to document the results of a biological resources assessment completed in support of the environmental review process for the proposed Paso Robles Peterbilt Dealership Development Project (Project) at 2805 Theatre Drive, Paso Robles, San Luis Obispo County, California (Project Site) (Figure 1-1 – Project Location); Assessor’s Parcel Number (APN) 009-851-022. This Report documents the results of a desktop review and field survey, and includes a discussion of existing biological resources, special-status biological resources that have the potential to occur within the proposed Project Site, potential Project impacts to these resources, and recommendations for impact avoidance and minimization measures.

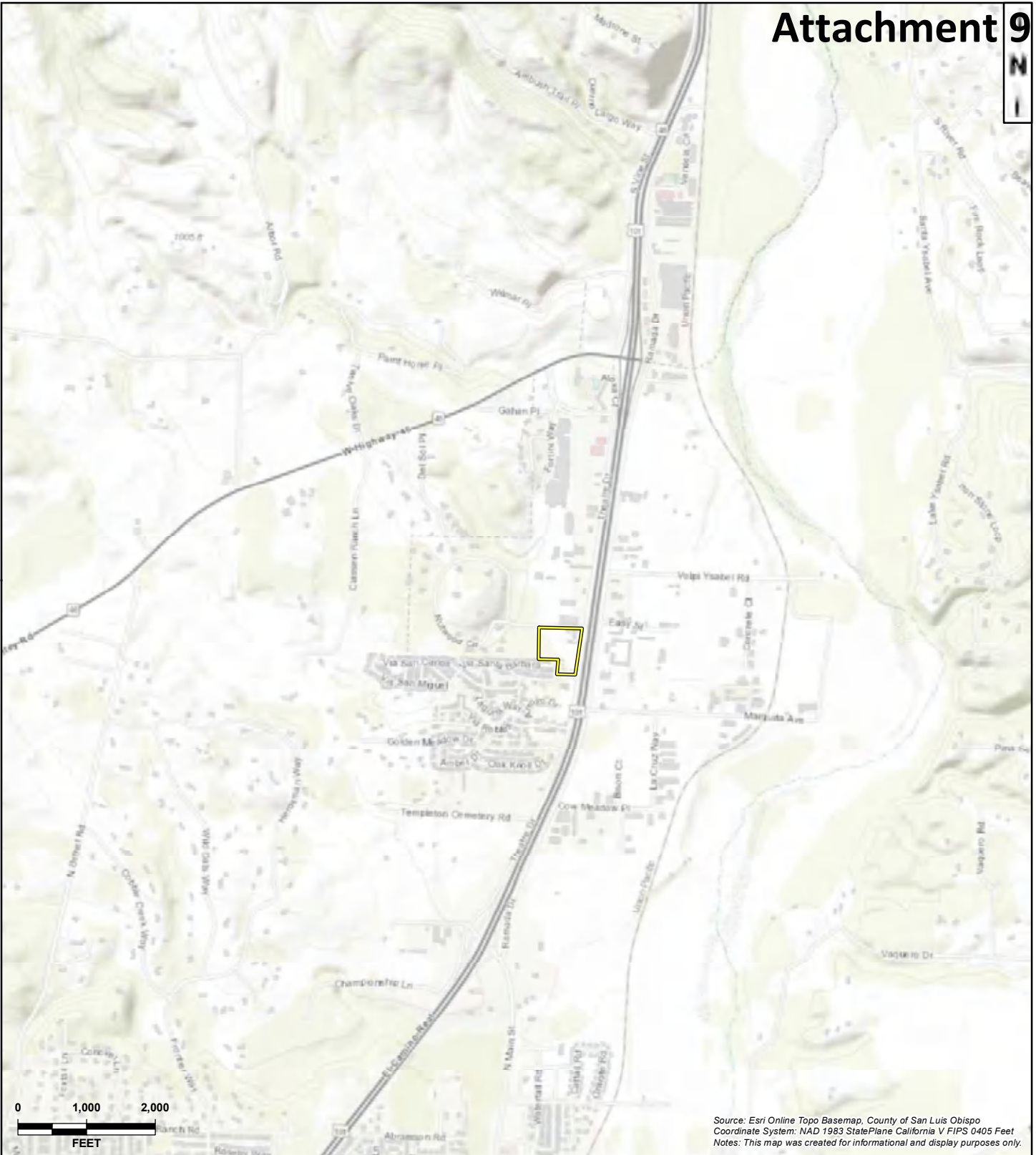

Source: Esri Online Topo Basemap, County of San Luis Obispo
 Coordinate System: NAD 1983 StatePlane California V FIPS 0405 Feet
 Notes: This map was created for informational and display purposes only.

LEGEND:
 Project Boundary

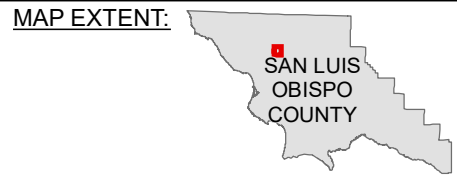

Z:\GIS\Projects\GIS Maps\Map Project\2805 Theatre Drive\Project Location.mxd 4/13/2022

	PROJECT NAME: 2805 THEATRE DRIVE SAN LUIS OBISPO COUNTY, CA		<h2>PROJECT LOCATION</h2>	FIGURE <h3>1-1</h3>
	PROJECT NUMBER: 2202-1101	DATE: April 2022		

2.0 REGULATORY FRAMEWORK

The regulatory framework identifies policies and plans administered by resource agencies pertaining to biological resources that are known to exist and/or have the potential to occur within the Project region.

2.1 FEDERAL REGULATIONS

2.1.1 Endangered Species Act of 1972.

The Federal Endangered Species Act (FESA), administered by the U.S. Fish and Wildlife Service (USFWS), the National Oceanic and Atmospheric Administration, and the National Marine Fisheries Service (NMFS), provides protection to species listed as Threatened or Endangered, and critical habitat designated for the protection of such species. The FESA prohibits “take” of Threatened and Endangered species (including plants) except under certain circumstances and only with authorization from the USFWS through a permit under sections 4(d), 7, or 10(a) of the FESA. Under the FESA, take is defined as to harass, harm, pursue, hunt, shoot, wound, kill, trap, capture, or collect, or to attempt to engage in any such conduct.

Critical Habitat is defined in Section 3(5)(A) of the FESA as: (1) specific areas within the geographical area occupied by the species at the time of listing, on which are found those physical or biological features that are essential to the conservation of the listed species and that may require special management considerations or protection; and (2) specific areas outside the geographical area occupied by the species at the time of listing that are essential for the conservation of a listed species.

The FESA also provides protection to those species proposed to be listed under FESA or critical habitats proposed to be designated for such species. In addition to the listed species, the federal government also maintains lists of species that are neither formally listed nor proposed but could potentially be listed in the future. These federal candidate species include taxa for which substantial information on biological vulnerability and potential threats exist and are maintained to support the appropriateness of proposing to list the taxa as an Endangered or Threatened species.

2.1.2 Migratory Bird Treaty Act

The USFWS also administers the Federal Migratory Bird Treaty Act (MBTA) of 1918 (16 USC 703-711). Under the MBTA, it is unlawful to take, possess, buy, sell, purchase, or barter any migratory bird listed in 50 CFR 10, including feathers or other parts of birds, nests, eggs or products, except as allowed by implementing regulations (50 CFR 21). In 2017, Solicitor of the Department of the Interior issued a legal opinion (M-37050 or M-Opinion) stating that “The Migratory Bird Treaty Act Does Not Prohibit Incidental Take” which in effect revoked take protections under the MBTA. On January 5, 2021, the USFWS published a final rule that defined the scope of the MBTA stating that incidental take of birds resulting from an activity is not prohibited when the underlying purpose of that activity is not to take birds. On May 6, 2021, the USFWS announced a proposed rule to revoke the January 7 final regulation that limited the scope of the MBTA, in an effort to reinstate federal MBTA protections. The proposed rule is pending as of June 2021.

In the interim, migratory birds are protected (for take) through AB 454 California Migratory Bird Protection Act (California Fish and Game Code 3513).

2.2 STATE REGULATIONS

2.2.1 California Fish and Game Code.

The California Department of Fish and Wildlife (CDFW) administers a number of laws and programs designed to protect plants, fish, and wildlife resources. Principal of these is the California Endangered Species Act of 1984 (CESA - Fish and Game Code Section 2050) that regulates the listing and take of State Endangered and Threatened species. CDFW also maintains lists of Candidate-Endangered species and Candidate-Threatened species. California candidate species are afforded the same level of protection as listed species. CDFW manages the California Native Plant Protection Act of 1977 (Fish and Game Code Section 1900, *et seq.*), which was enacted to identify, designate, and protect rare plants. The California Native Plant Society (CNPS) operates under a Memorandum of Understanding (MOU) with the CDFW which outlines broad cooperation in rare plant assessment and protection and formalizes cooperative ventures such as data sharing and production of complementary information sources for rare plants.

2.3 LOCAL REGULATIONS

San Luis Obispo County (County) incorporates all USFWS, CDFW, Regional Water Quality Control Board (RWQCB), and U.S. Army Corps of Engineers (ACOE) standards when assessing project impacts to vegetation, wildlife, and wetland habitats, as well as the California Environmental Quality Act (CEQA) evaluation process, when applicable. The County has developed a framework of land use policies and recommendations intended to reduce impacts to sensitive biological resources.

Oak trees are protected under San Luis Obispo County Land Use Ordinance, Title 22; Chapters 22.56 (Tree Preservation) and 22.58 (Oak Woodland Ordinance) (San Luis Obispo County 2021).

3.0 METHODS

Methods to collect biological resources information included a desktop review and field survey of the Biological Study Area (BSA), which encompassed the entire Project Site.

3.1 DESKTOP REVIEW

Prior to conducting the field survey, a query of the CDFW California Natural Diversity Data Base (CNDDDB) was conducted to identify documented occurrences of special-status plant and wildlife species, and sensitive habitats within the vicinity of the BSA. The CNDDDB is a continually refined and updated computerized inventory of rare animals, plants, and natural community location information in California, including species that are listed as federally and/or State endangered/threatened. All wildlife taxa listed with the CNDDDB are considered “special animals” in which the CDFW is interested in tracking, regardless of their legal protection status.

The Project Site is located within the Templeton 7.5-minute United States Geological Survey (USGS) quadrangle, and the CNDDDB search was focused on this and eight adjacent quadrangles within approximately ten miles of the BSA, including Paso Robles, Estrella, Creston, Santa Margarita, Atascadero, Morro Bay North, York Mountain, and Adelaida. The USFWS Critical Habitat database was also investigated to identify critical habitat for federally listed species within the BSA or surrounding region. In addition, the USFWS National Wetlands Inventory (NWI) was accessed to identify previously documented wetlands within the BSA or surrounding area.

3.2 FIELD SURVEYS

On March 31, 2022, Padre Biologists, Christina Santala and Shannon Gonzalez completed a field survey within the BSA focused on the existing biological resources, presence/absence of special-status plant and wildlife species and habitats, as well as the suitability of habitat to support these species within the BSA.

Field survey methods consisted of walking paths of opportunity throughout the BSA and recording wildlife species observed by visual observation using binoculars, indirect signs (e.g., tracks, scat, skeletal remains, and burrows), and/or auditory cues (i.e., calls and songs). Field notes on botanical resources and vegetation communities/habitats were also recorded. Field surveys were conducted in March, within the typical blooming period for most special-status plant species known to occur in the proposed Project region.

Vegetation within the BSA was divided and classified into vegetation types based on *A Manual of California Vegetation, Second Edition (MCV2)* (Sawyer, et. al., 2009), or described as site-specific vegetation and/or land use cover types not treated in the MCV2 (i.e., ruderal). All identifiable plant species observed within the BSA were documented. Plant specimens that were not positively identified in the field were further examined using appropriate botanical keys, including *The Jepson Manual Vascular Plants of California* (Baldwin et. al., 2012).

4.0 FINDINGS

The following discussion of biological resources includes those that were observed within the BSA, those identified in the desktop review, and resources that have the potential to occur based on the presence of suitable habitat. Supporting documentation includes Figure 4-1 – Biological Resources Assessment Results, Figure 4-2 – Regional Special-Status Biological Resources, Appendix A – Site Photographs, Appendix B – Plant List, Appendix C – Wildlife List, and Appendix D – CNDDDB Results.

4.1 ENVIRONMENTAL SETTING

The Project Site is located on the corner of Nutwood Circle and Theatre Drive, just west of Highway 101 in the City of Paso Robles, San Luis Obispo County, California. The Project Site is a vacant lot surrounded by residential and commercial development, with areas of previous disturbance (e.g., tilling, stockpiling, grading, etc.) and old infrastructure throughout the property. The topography of the area is level to moderately sloping and is situated on the eastern edge of the Santa Lucia Range.

4.2 BIOLOGICAL RESOURCES

4.2.1 Botanical

A list of plant species identified in the BSA during the March 2022 field survey is provided in Appendix B – Plant List. Vegetation communities documented to occur within the Project Site are described in the following paragraphs.

Wild oats and annual brome grassland (*Avena* spp. – *Bromus* spp. Herbaceous Semi-Natural Alliance). The Wild oats and annual brome grassland alliance occurs in all topographic settings in foothills, waste places, rangelands, and openings in woodlands. This alliance is characterized by presence of slender wild oats (*Avena barbata*), wild oats (*Avena fatua*), false brome (*Brachypodium distachyon*), rattlesnake grass (*Briza maxima*), ripgut brome (*Bromus diandrus*), soft chess (*Bromus hordeaceus*) and/or foxtail barley (*Hordeum murinum*) as dominant or co-dominant with other non-natives in the herbaceous layer; cover is open to continuous (Sawyer et. al., 2009). As observed during the field survey, this alliance occurred throughout the BSA. Dominant to co-dominant species included ripgut brome, wild oats, Mediterranean vetch (*Vicia benghalensis*), tocalote (*Centaurea melitensis*), red brome (*Bromus madritensis* ssp. *rubens*), redstem filaree (*Erodium cicutarium*), with sparse to moderate occurrences of common fiddleneck (*Amsinckia intermedia*), telegraph weed (*Heterotheca grandiflora*) and wild radish (*Raphanus sativus*). There were several sapling and mature valley oak (*Quercus lobata*) trees scattered throughout this vegetation alliance within the BSA. This alliance is not considered sensitive by the CDFW and is not protected under CEQA.

Ornamental. Within this Report, Ornamental is a site-specific vegetation classification that describes the planted landscape trees and shrubs within the BSA. As observed during the field survey, tree species included blue gum (*Eucalyptus globulus*), pine (*Pinus* sp.) and Coast live oak (*Quercus agrifolia*). Ornamental trees may provide suitable foraging and nesting habitat for fauna. This vegetation community is not considered sensitive by the CDFW and is not protected under CEQA.

Ruderal. Within this Report, Ruderal is a term used to describe the unpaved parking area within the BSA. This disturbed area can support vegetative cover consisting primarily of disturbance adapted plant species (ruderal species). As observed during the field survey, the Ruderal area consisted of bare ground with patches of non-native species including cheeseweed (*Malva parviflora*), redstem filaree, and barley. This vegetation community is not considered sensitive by the CDFW and is not protected under CEQA.

4.2.2 Wildlife

Wildlife was identified during the survey through indirect sign and direct observations of individuals. Species observed and detected included western fence lizard (*Sceloporus occidentalis*), California scrub jay (*Aphelocoma californica*), acorn woodpecker (*Melanerpes formicivorus*), house finch (*Haemorhous mexicanus*), and Botta's pocket gopher (*Thomomys bottae*). A complete list of observed wildlife species can be found in Appendix C – Wildlife Species Observed within the BSA.

4.2.3 Aquatic Resources

Based on the results of the desktop review and field observations, no aquatic resources were identified within the Project Site; however, several aquatic features were identified within one mile of the BSA. The NWI recorded features include a Riverine unnamed drainage approximately 0.07 miles south, the Salinas River approximately 0.8 miles east, a Freshwater Emergent Wetland approximately 0.3 miles northwest, and two Freshwater Ponds approximately 0.4 miles west of the BSA (USFWS, 2022b). In addition, an unrecorded drainage basin approximately 0.01 miles west of the Project Site was observed within the BSA during the March 2022 survey. This man-made basin appeared to collect water run-off from the street drain off Nutwood Circle and was vegetated with plant species similar to the surrounding grassland including tocalote, redstem filaree, and annual grasses. A fenced drainage basin was also present within the Project Site and supported vegetation similar to the surrounding grassland. No water was present in these aquatic features.

4.2.4 Oak Trees

Six valley oak trees of varying diameter at breast height (DBH) were observed throughout the Project Site (Figure 4-1). DBH for the six oak trees were as follows: 54 inches, 48 inches, 48 inches, 8 inches, 4 inches, and 4 inches.

4.3 SPECIAL-STATUS BIOLOGICAL RESOURCES

Results of the nine-quadrangle (approximately ten miles surrounding the Project Site) CNDDDB query for regional occurrences of special-status plant and wildlife species, and sensitive vegetation communities can be found in Appendix D (CDFW, 2022a). This Report focuses on the special-status plants and wildlife biological resources within five miles of the BSA (Project region)

that have a greater potential to occur within the Project Site based on proximity of documented occurrences. Figure 4-2 depicts CNDDDB occurrences and USFWS Critical Habitat within five miles of the Project Site.



Source: Esri Online Imagery/Basemap, County of San Luis Obispo
 Coordinate System: NAD 1983 State Plane California V FIPS 10405 Feet
 Notes: This map was created for informational and display purposes only.

LEGEND:

- | | | |
|------------------|---------------------------------------|--------------------------------------|
| Project Boundary | Drainage Basin | Vegetation Communities |
| BSA Boundary | Remnant soil/gravel stockpile feature | Ornamental |
| Culvert | Tree | Ruderal |
| | Valley Oak | Wild oats and annual brome grassland |

MAP EXTENT:

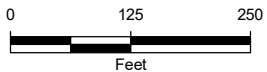

PROJECT NAME: 2805 THEATRE DRIVE SAN LUIS OBISPO COUNTY, CA	
PROJECT NUMBER: 2202-1101	DATE: April 2022

**BIOLOGICAL RESOURCES
ASSESSMENT RESULTS MAP**

Z:\GIS\Projects\GIS Maps\Map Project\2805 Theatre Drive\Biological Resources Assessment Results Map.mxd - 4/14/2022

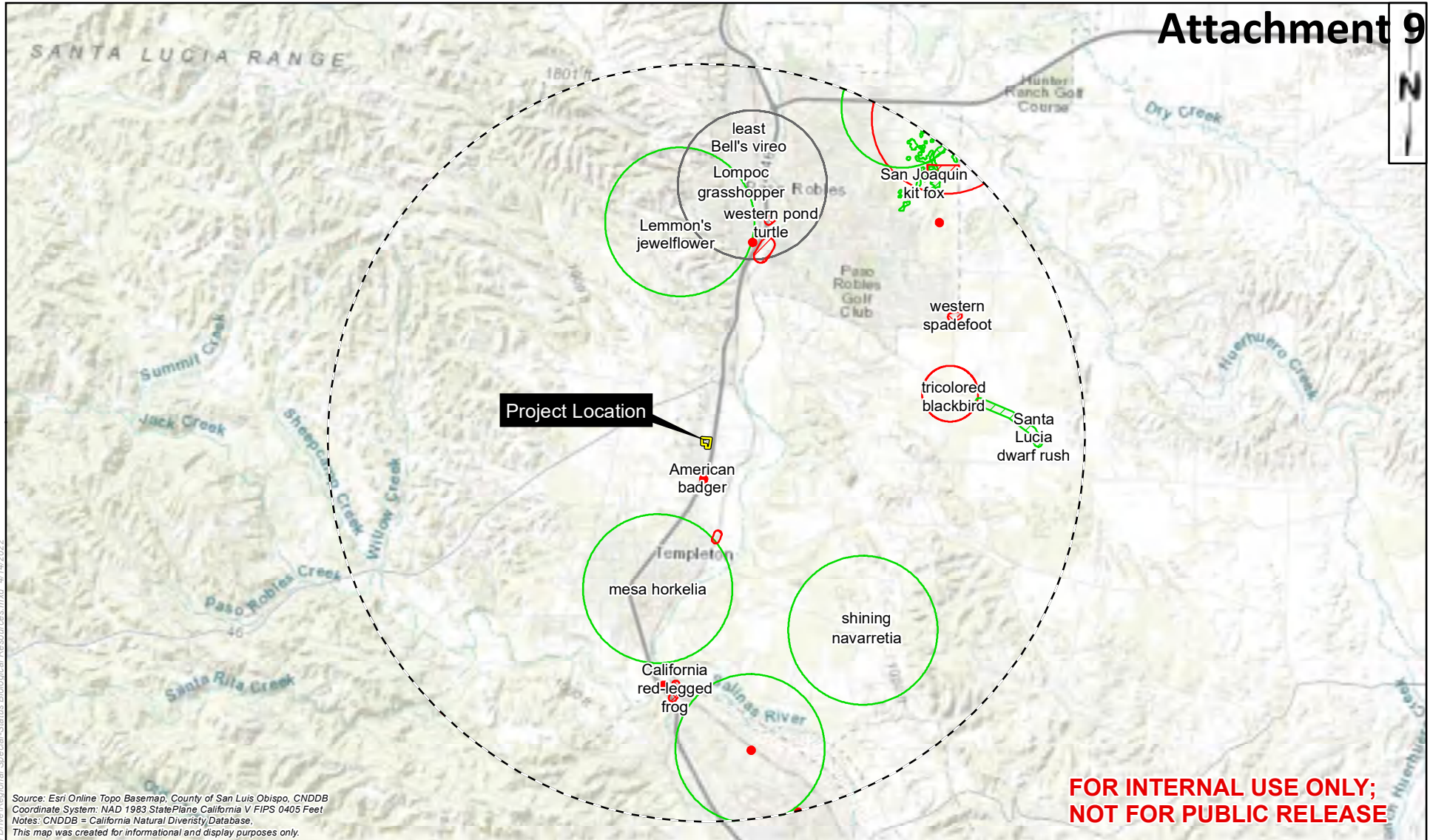

Source: Esri Online Topo Basemap, County of San Luis Obispo, CNDDB
 Coordinate System: NAD 1983 StatePlane California V FIPS 0405 Feet
 Notes: CNDDB = California Natural Diversity Database.
 This map was created for informational and display purposes only.

**FOR INTERNAL USE ONLY;
 NOT FOR PUBLIC RELEASE**

LEGEND:

- | | | | |
|------------------|--------------------------|-------------------|-----------------------|
| Project Boundary | CNDDB Occurrences | Plant (circular) | Animal (non-specific) |
| Buffer - 5 miles | Plant (specific) | Animal (80m) | Animal (circular) |
| | Plant (non-specific) | Animal (specific) | Multiple (circular) |

MAP EXTENT:

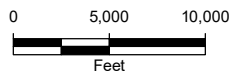

PROJECT NAME: 2805 THEATRE DRIVE
 SAN LUIS COUNTY, CA

PROJECT NUMBER: 2202-1101 DATE: April 2022

**REGIONAL SPECIAL-STATUS
 BIOLOGICAL RESOURCES MAP**

**FIGURE
 4-2**

Z:\GIS\Projects\GIS Maps\Map Project\2805 Theatre Drive Regional Special-Status Biological Resources.mxd 4/14/2022

4.3.1 Special-Status Habitats

No USFWS-Designated Critical Habitat overlaps the BSA. The nearest occurrence is vernal pool fairy shrimp (*Branchinecta lynchi*) USFWS-Designated Critical Habitat approximately 5.4 miles northeast of the BSA (USFWS, 2022a).

Valley Oak Woodland, a sensitive natural community defined by CDFW, is documented within five miles of the BSA; however, this natural community is not present within the Project Site (CDFW, 2022a).

4.3.2 Special-Status Botanical

Special-status plants are either listed as Endangered or Threatened under FESA or CESA, considered Rare under the California Native Plant Protection Act, or considered rare (but not legally listed) by resources agencies, professional organizations, and the scientific community under the following categories:

1. Plants listed or proposed for listing as Threatened or Endangered under the Federal Endangered Species Act (50 CFR 17.12 for listed plants and various notices in the Federal Register for proposed species,).
2. Plants that are candidates for possible future listing as Threatened or Endangered under the Federal Endangered Species Act (Federal Register October 10, 2019).
3. Plants that meet the definitions of rare or endangered species under the CEQA (State CEQA Guidelines, Section 15380).
4. Plants considered by the CNPS to be "Rare, Threatened, or Endangered" in California (Ranks 1B and 2 in CNPS, 2020).
5. Plants listed by CNPS as plants about which we need more information and plants of limited distribution (Ranks 3 and 4 in CNPS, 2020).
6. Plants listed or proposed for listing by the State of California as Threatened or Endangered under the California Endangered Species Act (14 CCR 670.5).
7. Plants listed under the California Native Plant Protection Act (California Fish and Game Code 1900 et seq.).
8. Plants considered sensitive by other Federal agencies (i.e., U.S. Forest Service, Bureau of Land Management), state and local agencies or jurisdictions.
9. Plants considered sensitive or unique by the scientific community or occurring at the limits of their natural range (State CEQA Guidelines).

Based on the CNDDDB query completed as part of the desktop review, there were 43 special-status plant species documented within approximately ten miles of the BSA (Appendix D). Of these species, one species, Lemmon's jewelflower (*Caulanthus lemmonii*), had a greater potential to occur within the Project Site based on proximity of documented occurrences (less than five miles) and presence of generally suitable habitat (grassland) within the BSA.

No special-status plant species were observed during the March 2022 field survey. The survey was conducted within the typical blooming period for potentially occurring special-status plant species of the region and would be identifiable in March. Based on the field survey observations and habitat conditions (dominance of disturbance-adapted plant species) no special-status plant species are likely to occur within the Project Site.

4.3.3 Special-Status Wildlife

Special-status wildlife species are either listed as Endangered or Threatened under FESA or CESA, or considered rare (but not formally listed) by resources agencies, professional organizations, and the scientific community under the following categories:

- Animals listed or proposed for listing as Threatened or Endangered under the Federal Endangered Species Act (50 CFR 17.11 for listed animals and various notices in the Federal Register for proposed species).
- Animals that are candidates for possible future listing as Threatened or Endangered under the Federal Endangered Species Act (Federal Register October 10, 2019).
- Animals that meet the definitions of rare or endangered species under the CEQA (*State CEQA Guidelines*, Section 15380)
- Animal considered Species of Special Concern (SSC) by CDFW (Shuford and Gardali, 2008 for birds; Williams, 1986 for mammals; Moyle et al., 2015 for fish; and Thomson et al., 2016 for amphibians and reptiles).
- Animals listed or proposed for listing by the State of California as Threatened and Endangered under the California Endangered Species Act (14 CCR 670.5).
- Animal species that are fully protected in California (California Fish and Game Code, Section 3511 [birds], 4700 [mammals], and 5050 [reptiles and amphibians]).
- Animal species protected under the Marine Mammal Protection Act (as amended in 1994).
- Birds of Conservation Concern. Migratory and nonmigratory bird species (beyond those already designated as federally Threatened or Endangered) that represent the USFWS highest conservation priorities in effort to draw attention to species in need of conservation action (Shuford and Gardali, 2008).
- Birds on the CDFW Watch List include “Taxa to Watch” (Shuford and Gardali, 2008) 1) not on the current Special Concern list but were on previous lists and they have not been state listed under CESA; 2) were previously state or federally listed and now are on neither list; or 3) are on the list of “Fully Protected” species.

Based on the CNDDDB query completed as part of the desktop review, there were 38 special-status wildlife species documented within approximately ten miles of the BSA. Of those 38, there are three special-status wildlife species with the potential to occur within the Project Site based on suitable habitat and regional (less than five miles) documented occurrences. These species include Northern California legless lizard (*Anniella pulchra*), American badger (*Taxidea taxus*), and San Joaquin kit fox (*Vulpes macrotis mutica*).

No special-status wildlife species were observed during the March 2022 field survey. However, the Project Site may provide suitable habitat to support the special-status wildlife species listed above. The following sections provide an overview of the general habitat requirements for these species and further detail on the potential for each of these species to occur in the Project Site.

4.3.3.1 Reptiles

Northern legless lizard is a predominantly subterranean lizard that occupies moist, warm, and loose soils with vegetative cover (Stebbins, 2003). It has the potential to utilize areas of the Project Site that have dense leaf litter. Refer to Section 6.0 for recommended mitigation measures for protection of Northern legless lizard during Project activities.

4.3.3.2 Mammals

American badger is a CDFW Species of Special Concern and San Joaquin kit fox is listed as Federally Endangered and State Threatened. The annual grassland habitat, and presence of small mammal (ground squirrel) burrows indicate that general conditions within the Project Site are suitable for both species. No large burrows or sign (i.e., scat, tracks, prey remains, etc.) were identified during the March 2022 survey. Further, the Project Site is situated adjacent to Highway 101 and is surrounded by residential and commercial development that creates significant dispersal barriers for these species. However, because there are documented occurrences within five miles, and generally suitable grassland habitat is, there is a low potential for American badger and San Joaquin kit fox to occur within the Project Site. Refer to Section 6.0 for recommended mitigation measures for protection of these species during Project activities.

4.3.3.3 Nesting Birds

No nesting bird activity was observed within the BSA during the March 2022 field survey; however, trees and vegetation present within or adjacent to the Project Site provide suitable nesting habitat for a variety of bird species. Nesting birds and their nests/eggs are protected under the federal Migratory Bird Treaty Act of 1918 and California Fish and Game Code. Nesting bird season generally occurs between February 1 and August 31. Refer to Section 6.0 for recommended mitigation measures for protection of potentially nesting birds during Project activities.

5.0 POTENTIAL IMPACTS

The proposed Project would include development of most of the Project Site. Grading and construction activities have the potential to impact special-status biological resources that have the potential to occur within the Project Site.

Potential impacts to special-status biological resources are construction-related, including mortality or injury from equipment operations, vehicle traffic, and loss of habitat. Project-related noise also has the potential to negatively affect nesting bird activity within or adjacent to the Project Site. Refer to Section 6.0 for recommended mitigation measures to avoid and/or minimize impacts to special-status biological resources.

6.0 RECOMMENDED MITIGATION MEASURES

Implementation of the following avoidance and minimization measures are recommended to protect sensitive biological resources to the greatest extent feasible during proposed Project activities:

1. Work Timing. All work activities shall be completed during daylight hours (between sunrise and sunset) and outside of rain events;
2. Work Limits. The Project impact area shall be clearly marked or delineated with stakes, flagging, tape, or signage prior to work. Areas outside of work limits shall be considered environmentally sensitive and shall not be disturbed;
3. Vehicles and Equipment. All equipment and vehicles shall be checked and maintained daily to prevent spills of fuel, oil, and other hazardous materials. A designated staging area shall be established for vehicle/equipment parking and storage of fuel, lubricants, and solvents. All fueling and maintenance activities shall take place in the staging area;
4. Pre-Activity Nesting Bird Survey. If vegetation removal (i.e., tree trimming/removal activities) is scheduled between February 1 and August 31 (general nesting bird season), nesting bird surveys shall be completed by a qualified biologist within 48 hours prior to start of work. If any active nests are discovered within or adjacent to work limits, an appropriate buffer (i.e., 500 feet for raptors and 250 feet for other birds, or at the discretion of a qualified biologist based on biological or ecological reasons) shall be established to protect the nest until a qualified biologist has determined that the nest is no longer active and/or the young have fledged;
5. Pre-Activity Special-Status Species Survey. Within 30 days of the start of construction, a qualified biologist shall conduct a pre-activity survey of the Project Site for signs of San Joaquin kit fox and American badger, including tracks, scat, or suitable burrows (burrows four inches or greater in diameter). Potential dens shall be tracked for a minimum of four nights with motion-activated cameras to determine if the burrow is actively being used by San Joaquin kit fox or badger. All potential dens shall be avoided by a minimum of 50 feet until they have been determined to be inactive. In the event San Joaquin kit fox is identified within the Project Site, the USFWS, CDFW, and all other appropriate agencies/government entities shall be contacted for further consultation.

In conjunction with the badger and kit fox survey, the qualified biologist will conduct a survey for Northern legless lizard. Hand search methods, including raking, will be used during the survey in areas where legless lizards are expected to be found (e.g., sandy/loose soils, under shrubs/leaf litter, other vegetation, or debris). If observed, the qualified biologist will relocate the lizard to nearby suitable habitat. The qualified biologist will prepare a completion letter-report to document the pre-activity survey results.

6. Oak Tree Removal. If oak tree removal and/or damage is unavoidable due to Project implementation, the County may require mitigation for impacts to mature oak trees.

Mitigation may require preparation of an oak tree protection and replacement plan that would provide guidance for onsite and/or offsite oak tree replacement planting.

7.0 REFERENCES

- Baldwin, Bruce G., Goldman, Douglas H., Keil, David J., Rosatti, Thomas J. 2012. The Jepson Manual: Vascular Plants of California, Second Edition. University of California Press. Berkeley, California.
- California Department of Fish and Wildlife (CDFW). 2022a. California Natural Diversity Database (CNDDDB) Rare Find Paso Robles, Estrella, Creston, Santa Margarita, Atascadero, Morro Bay North, York Mountain, and Adelaida.7.5-minute U.S. Geological Survey (USGS) quadrangles.
- 2022b. Special Animals List. State of California Natural Resources Agency Department of Fish and Wildlife Biogeographic Data Branch California Natural Diversity Database (CNDDDB). October 2021.
- Calflora. 2022. Information on California plants for education, research and conservation. [web application]. 2022. Berkeley, California: The Calflora Database [a non-profit organization]. Available: <https://www.calflora.org/> (Accessed March 2022).
- California Native Plant Society, Rare Plant Program. 2022. Inventory of Rare and Endangered Plants of California (online edition, v8-03 0.39). Website <http://www.rareplants.cnps.org> [accessed March 2022].
- San Luis Obispo County. San Luis Obispo County Municipal Code; Title 22 –Land Use Ordinance; Article 5 – Site Development Standards; Title 22; Chapter 22.56 Tree Preservation and Chapter 22.58 Oak Woodland Ordinance.
- Sawyer, John O., Keeler-Wolf, Todd, Evens, Julie. 2009. A Manual of California Vegetation Second Edition. California Native Plant Society. Berkeley, California.
- Stebbins, Robert C. 2003. A Field Guide to Western Reptiles and Amphibians, Third Edition. Houghton Mifflin Company. New York, NY.
- United States Fish and Wildlife Service (USFWS). 2022a. Critical Habitat Portal. Retrieved from <https://ecos.fws.gov/ecp/report/table/critical-habitat.html>.
- 2022b. National Wetlands Inventory (NWI). Wetlands Mapper. Retrieved from <https://www.fws.gov/wetlands/data/Mapper.html>.

APPENDIX A

Site Photographs



Photo 1. Representative view of Wild oats and annual brome grassland vegetation within the BSA.



Photo 2. Representative view of valley oak tree and Ornamental vegetation within the BSA.



Photo 3. Ruderal area adjacent to Theater Drive.



Photo 4. Representative view of vegetated soil/gravel stockpile feature within the BSA.



Photo 5. Fenced drainage basin within the BSA.



Photo 6. View of storm drain and culvert to direct flow from Nutwood Circle into shallow drainage basin located off-site (north) of the Project Site.

APPENDIX B

Plant List

List of Plant Species Observed
Paso Robles Peterbilt Biological Resources Assessment, Paso Robles, CA

Attachment 9

FAMILY	Scientific Name	Common Name	Habit	Wetland Indicator Status	Native Status	Cal-IPC Rating	Listing Status
ARALIACEAE	<i>Hedera helix</i>	English ivy	PV	FACU		High	
ASTERACEAE	<i>Baccharis pilularis</i>	Coyote brush	S	-	N		
	<i>Centaurea melitensis</i>	Tocalote	AH	-		Moderate	
	<i>Heterotheca grandiflora</i>	Telegraph weed	AH	-			
	<i>Hypochaeris glabra</i>	Smooth cat's ear	AH	-		Limited	
	<i>Silybum marianum</i>	Milk thistle	A/PH	-		Limited	
	<i>Uropappus lindleyi</i>	Silverpuffs	AH	-	N		
BORAGINACEAE	<i>Amsinckia intermedia</i>	Common fiddleneck	AH	-	N		
BRASSICACEAE	<i>Brassica nigra</i>	Black mustard	AH	-		Moderate	
	<i>Raphanus sativus</i>	Wild radish	AH	-		Limited	
CONVOLVULACEAE	<i>Convolvulus arvensis</i>	Bindweed	PH	-			
CUPRESSACEAE	<i>Hesperocyparis macrocarpa</i> *	Monterey cypress	T	-	N		1B.2
FABACEAE	<i>Vicia benghalensis</i>	Mediterranean vetch	AH/V	-			
FAGACEAE	<i>Quercus agrifolia</i> *	Coast live oak	T	-	N		
	<i>Quercus lobata</i>	Valley oak	T	FACU	N		
GERANIACEAE	<i>Erodium cicutarium</i>	Redstem filaree	AH	-		Limited	
MALVACEAE	<i>Malva parviflora</i>	Cheese-weed	AH	-			
POACEAE	<i>Avena barbata</i>	Slender wild oats	AG	-		Moderate	
	<i>Avena fatua</i>	Wild oats	AG	-		Moderate	
	<i>Bromus diandrus</i>	Ripgut grass	AG	-		Moderate	
	<i>Bromus hordeaceus</i>	Soft chess	AG	FACU		Limited	
	<i>Bromus madritensis ssp. rubens</i>	Red brome	AG	-		High	
	<i>Festuca myuros</i>	Rattail fescue	AG	FACU		Moderate	
	<i>Hordeum murinum ssp. leporinum</i>	Barley	AG	FACU			
POLYGONACEAE	<i>Rumex crispus</i>	Curly dock	PH	FAC		Limited	
PINACEAE	<i>Pinus radiata</i> *	Monterey pine	T	-	N		
	<i>Larix sp.</i> *	Larch	T	-			
RUBIACEAE	<i>Galium aparine</i>	Bedstraw	AH	FACU	N		

Notes:

Scientific nomenclature follows Baldwin (2012).

* Planted as landscape tree

N - Native species

Habit definitions:

AG - Annual grass.

AH - Annual herb.

F - Fern

PG - Perennial grass.

List of Plant Species Observed
Paso Robles Peterbilt Biological Resources Assessment, Paso Robles, CA

Attachment 9

PH - Perennial herb.

PV - Perennial vine.

S - Shrub

T - Tree

Wetland indicator status (Lichvar and Kartesz, 2016):

OBL (Obligate Wetland Plants) - Almost always occur in wetlands.

FACW (Facultative Wetland Plants) - Usually occur in wetland, but may occur in non-wetlands.

FAC (Facultative Wetland Plants) - Occur in wetlands and non-wetlands.

FACU (Facultative Upland Plants) - Usually occur in non-wetlands, but may occur in wetlands.

UPL (Upland Plants) - Almost always occur in non-wetlands.

Cal-IPC (California Invasive Plant Council) Ratings:

High - These species have severe ecological impacts on physical processes, plant and animal communities, and vegetation structure. Most are widely distributed ecologically.

Moderate - These species have substantial and apparent-but generally not severe-ecological impacts on physical processes, plant and animal communities, and vegetation

Limited - These species are invasive but their ecological impacts are minor on a statewide level or there was not enough information to justify a higher score.

Listing Status:

FE - Federally endangered

FT - Federally threatened

SE - State endangered

ST - State threatened

CNPS (California Native Plant Society) Ranking System; CRPR (California Rare Plant Rank):

1A - Plants presumed extirpated in California and either rare or extinct elsewhere

1B - Plants rare, threatened, or endangered in California and elsewhere

2A - Plants presumed extirpated in California, but common elsewhere

2B - Plants, rare, threatened, or endangered in California, but more common elsewhere

3 - Plants about which more information is needed – a review list

4 - Plant of limited distribution – a watch list

CRPR Threat Ranks:

0.1 - Seriously threatened in California

0.2 - Moderately threatened in California

0.3 - Not very threatened in California

APPENDIX C

Wildlife List

**Wildlife Species Observed within the BSA
2805 Theatre Drive, Paso Robles, California**

Attachment 9

Common Name	Scientific Name	Residence Status	Protected Status	Habitat
Reptiles				
Western fence lizard	<i>Sceloporus occidentalis</i>	R	--	G, D, P, S, M
Birds				
Acorn woodpecker	<i>Melanerpes formicivorus</i>	R	M	P
California scrub-jay	<i>Aphelocoma californica</i>	R	M	R, G, P
House finch	<i>Haemorhous mexicanus</i>	R	M	P, D, M
Mourning dove	<i>Zenaida macroura</i>	R	M	P, D, M
Northern mockingbird	<i>Mimus polyglottos</i>	R	M	S, G, D, M
Red-tailed hawk	<i>Buteo jamaicensis</i>	R	M	G, P, M
Turkey vulture	<i>Cathartes aura</i>	R	M	P, M
Yellow-rumped warbler	<i>Setophaga coronata</i>	R	M	P
Mammals				
Botta's pocket gopher	<i>Thomomys bottae</i>	R	--	R, G, P
California ground squirrel	<i>Otospermophilus beecheyi</i>	R	--	G, M, P

Notes:

Fauna observed by visualizations, indirect signs (tracks, scat, skeletal remains, burros, etc.), and/or auditory cues.

Residence Status	Protected Status	Typical Habitat
R - Permanent resident	FE - Federal	A - Aquatic
W - Winter resident	FT - Federal threatened species	D - Developed areas
B - Summer resident	FC - Federal candidate species	G - Grassland
	M - Migratory Bird Treaty Act	M - Multiple habitats
	SE - State endangered species	P - Woodland
	ST - State threatened species	R - Riparian
	CS - Candidate species for CESA	W - Wetland
	CSC - California Species of Special Concern	C - Coastal lagoons, shores, oceans
	CFP - California Fully Protected Species	O - Rock outcrops
	BCC - Bird of Conservation Concern (USFWS)	S - Scrub

APPENDIX D

CNDDDB Results

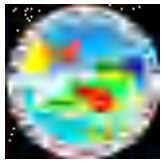

Summary Table Report
California Department of Fish and Wildlife
California Natural Diversity Database

Attachment 9



Query Criteria: Quad IS Templeton (3512056) OR Paso Robles (3512066) OR Estrella (3512065) OR Creston (3512055) OR Santa Margarita (3512045) OR Atascadero (3512046) OR Morro Bay North (3512047) OR York Mountain (3512057) OR Adelaida (3512067))
 AND Taxonomic Group IS (Dune OR Scrub OR Herbaceous OR Marsh OR Riparian OR Woodland OR Forest OR Alpine OR Inland Waters OR Marine OR Estuarine OR Riverine OR Palustrine OR Fish OR Amphibians OR Reptiles OR Birds OR Mammals OR Mollusks OR Arachnids OR Crustaceans OR Insects OR Ferns OR Gymnosperms OR Monocots OR Dicots OR Lichens OR Bryophytes OR Fungi)

Name (Scientific/Common)	CNDDB Ranks	Listing Status (Fed/State)	Other Lists	Elev. Range (ft.)	Total EO's	Element Occ. Ranks						Population Status		Presence		
						A	B	C	D	X	U	Historic > 20 yr	Recent <= 20 yr	Extant	Poss. Extirp.	Extirp.
<i>Abies bracteata</i> bristlecone fir	G2G3 S2S3	None None	Rare Plant Rank - 1B.3 IUCN_NT-Near Threatened SB_CalBG/RSABG-California/Rancho Santa Ana Botanic Garden USFS_S-Sensitive		80 S:1	0	0	0	0	0	1	1	0	1	0	0
<i>Agelaius tricolor</i> tricolored blackbird	G1G2 S1S2	None Threatened	BLM_S-Sensitive CDFW_SSC-Species of Special Concern IUCN_EN-Endangered NABCI_RWL-Red Watch List USFWS_BCC-Birds of Conservation Concern	684 1,036	955 S:3	0	0	0	0	0	3	1	2	3	0	0
<i>Agrostis hooveri</i> Hoover's bent grass	G2 S2	None None	Rare Plant Rank - 1B.2 BLM_S-Sensitive USFS_S-Sensitive	1,000 1,000	31 S:1	0	0	0	0	0	1	1	0	1	0	0
<i>Ammodramus savannarum</i> grasshopper sparrow	G5 S3	None None	CDFW_SSC-Species of Special Concern IUCN_LC-Least Concern	984 984	27 S:1	0	0	1	0	0	0	0	1	1	0	0
<i>Anniella pulchra</i> Northern California legless lizard	G3 S3	None None	CDFW_SSC-Species of Special Concern USFS_S-Sensitive	80 1,263	383 S:10	0	1	0	0	0	9	9	1	10	0	0
<i>Antirrhinum ovatum</i> oval-leaved snapdragon	G3 S3	None None	Rare Plant Rank - 4.2	720 720	16 S:1	0	0	0	0	0	1	1	0	1	0	0

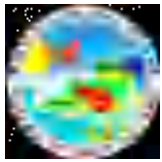

Summary Table Report
California Department of Fish and Wildlife
California Natural Diversity Database

Attachment 9



Name (Scientific/Common)	CNDDB Ranks	Listing Status (Fed/State)	Other Lists	Elev. Range (ft.)	Total EO's	Element Occ. Ranks						Population Status		Presence		
						A	B	C	D	X	U	Historic > 20 yr	Recent <= 20 yr	Extant	Poss. Extirp.	Extirp.
<i>Antrozous pallidus</i> pallid bat	G4 S3	None None	BLM_S-Sensitive CDFW_SSC-Species of Special Concern IUCN_LC-Least Concern USFS_S-Sensitive WBWG_H-High Priority	175 1,050	420 S:2	0	1	0	0	0	1	1	1	2	0	0
<i>Aquila chrysaetos</i> golden eagle	G5 S3	None None	BLM_S-Sensitive CDF_S-Sensitive CDFW_FP-Fully Protected CDFW_WL-Watch List IUCN_LC-Least Concern USFWS_BCC-Birds of Conservation Concern	720 1,340	324 S:2	1	1	0	0	0	0	1	1	2	0	0
<i>Arctostaphylos luciana</i> Santa Lucia manzanita	G2 S2	None None	Rare Plant Rank - 1B.2 SB_CalBG/RSABG-California/Rancho Santa Ana Botanic Garden SB_UCSC-UC Santa Cruz USFS_S-Sensitive	2,700 2,700	10 S:1	0	0	0	0	0	1	1	0	1	0	0
<i>Arctostaphylos pilosula</i> Santa Margarita manzanita	G2? S2?	None None	Rare Plant Rank - 1B.2 BLM_S-Sensitive SB_SBBG-Santa Barbara Botanic Garden USFS_S-Sensitive	955 1,400	58 S:4	1	0	0	0	0	3	2	2	4	0	0
<i>Ardea herodias</i> great blue heron	G5 S4	None None	CDF_S-Sensitive IUCN_LC-Least Concern	996 996	156 S:1	0	0	0	0	0	1	0	1	1	0	0
<i>Astragalus didymocarpus var. milesianus</i> Miles' milk-vetch	G5T2 S2	None None	Rare Plant Rank - 1B.2	1,250 1,250	16 S:3	0	0	0	0	0	3	3	0	3	0	0
<i>Atractelmis wawona</i> Wawona riffle beetle	G3 S1S2	None None		231 231	80 S:1	0	0	0	0	0	1	0	1	1	0	0
<i>Batrachoseps minor</i> lesser slender salamander	G1 S1	None None	CDFW_SSC-Species of Special Concern IUCN_DD-Data Deficient USFS_S-Sensitive	895 1,376	8 S:7	0	0	0	0	0	7	1	6	7	0	0

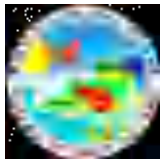

Summary Table Report
California Department of Fish and Wildlife
California Natural Diversity Database

Attachment 9



Name (Scientific/Common)	CNDDB Ranks	Listing Status (Fed/State)	Other Lists	Elev. Range (ft.)	Total EO's	Element Occ. Ranks						Population Status		Presence		
						A	B	C	D	X	U	Historic > 20 yr	Recent <= 20 yr	Extant	Poss. Extirp.	Extirp.
<i>Bombus caliginosus</i> obscure bumble bee	G4? S1S2	None None	IUCN_VU-Vulnerable	1,200 1,200	181 S:1	0	0	0	0	0	1	1	0	1	0	0
<i>Bombus crotchii</i> Crotch bumble bee	G3G4 S1S2	None None		900 1,300	437 S:3	0	0	0	0	0	3	3	0	3	0	0
<i>Branchinecta lynchi</i> vernal pool fairy shrimp	G3 S3	Threatened None	IUCN_VU-Vulnerable	725 1,125	795 S:6	0	2	3	1	0	0	4	2	6	0	0
<i>Buteo regalis</i> ferruginous hawk	G4 S3S4	None None	CDFW_WL-Watch List IUCN_LC-Least Concern USFWS_BCC-Birds of Conservation Concern	995 995	107 S:1	0	1	0	0	0	0	0	1	1	0	0
<i>Calochortus obispoensis</i> San Luis mariposa-lily	G2 S2	None None	Rare Plant Rank - 1B.2 SB_CalBG/RSABG-California/Rancho Santa Ana Botanic Garden SB_SBBG-Santa Barbara Botanic Garden USFS_S-Sensitive	1,300 1,700	46 S:3	0	1	0	0	0	2	0	3	3	0	0
<i>Calochortus simulans</i> La Panza mariposa-lily	G2 S2	None None	Rare Plant Rank - 1B.3 SB_CRES-San Diego Zoo CRES Native Gene Seed Bank SB_SBBG-Santa Barbara Botanic Garden USFS_S-Sensitive	1,000 1,600	109 S:14	0	5	2	3	0	4	4	10	14	0	0
<i>Calycadenia villosa</i> dwarf calycadenia	G3 S3	None None	Rare Plant Rank - 1B.1 SB_SBBG-Santa Barbara Botanic Garden USFS_S-Sensitive	984 1,130	59 S:4	0	2	0	0	0	2	4	0	4	0	0
<i>Camissoniopsis hardhamiae</i> Hardham's evening-primrose	G2 S2	None None	Rare Plant Rank - 1B.2 BLM_S-Sensitive USFS_S-Sensitive	1,100 1,600	22 S:7	3	3	0	0	0	1	6	1	7	0	0
<i>Carex obispoensis</i> San Luis Obispo sedge	G3? S3?	None None	Rare Plant Rank - 1B.2 BLM_S-Sensitive SB_SBBG-Santa Barbara Botanic Garden USFS_S-Sensitive	1,600 2,500	29 S:3	1	0	0	0	0	2	2	1	3	0	0

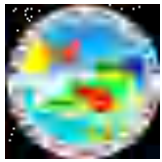

Summary Table Report
California Department of Fish and Wildlife
California Natural Diversity Database

Attachment 9



Name (Scientific/Common)	CNDDB Ranks	Listing Status (Fed/State)	Other Lists	Elev. Range (ft.)	Total EO's	Element Occ. Ranks						Population Status		Presence		
						A	B	C	D	X	U	Historic > 20 yr	Recent <= 20 yr	Extant	Poss. Extirp.	Extirp.
<i>Castilleja densiflora var. obispoensis</i> San Luis Obispo owl's-clover	G5T2 S2	None None	Rare Plant Rank - 1B.2	75 1,580	69 S:7	0	1	2	0	0	4	3	4	7	0	0
<i>Caulanthus lemmonii</i> Lemmon's jewelflower	G3 S3	None None	Rare Plant Rank - 1B.2 BLM_S-Sensitive SB_SBBG-Santa Barbara Botanic Garden USFS_S-Sensitive	1,000 1,000	91 S:4	0	0	0	0	0	4	4	0	4	0	0
<i>Charadrius nivosus nivosus</i> western snowy plover	G3T3 S2	Threatened None	CDFW_SSC-Species of Special Concern NABCI_RWL-Red Watch List USFWS_BCC-Birds of Conservation Concern	10 10	138 S:2	0	1	1	0	0	0	0	2	2	0	0
<i>Chorizanthe breweri</i> Brewer's spineflower	G3 S3	None None	Rare Plant Rank - 1B.3 BLM_S-Sensitive USFS_S-Sensitive	1,000 2,500	45 S:7	2	0	0	0	0	5	4	3	7	0	0
<i>Chorizanthe rectispina</i> straight-awned spineflower	G2 S2	None None	Rare Plant Rank - 1B.2 BLM_S-Sensitive USFS_S-Sensitive	1,000 1,900	38 S:10	2	1	1	0	0	6	7	3	10	0	0
<i>Cicindela hirticollis gravida</i> sandy beach tiger beetle	G5T2 S2	None None		10 10	34 S:2	0	0	0	0	1	1	2	0	1	0	1
<i>Cirsium fontinale var. obispoense</i> Chorro Creek bog thistle	G2T2 S2	Endangered Endangered	Rare Plant Rank - 1B.2 SB_CalBG/RSABG-California/Rancho Santa Ana Botanic Garden SB_SBBG-Santa Barbara Botanic Garden	1,000 1,000	22 S:1	0	0	0	0	0	1	1	0	1	0	0
<i>Cirsium occidentale var. lucianum</i> Cuesta Ridge thistle	G3G4T2 S2	None None	Rare Plant Rank - 1B.2		9 S:1	0	0	0	0	0	1	1	0	1	0	0
<i>Coelus globosus</i> globose dune beetle	G1G2 S1S2	None None	IUCN_VU-Vulnerable	10 10	50 S:2	0	0	0	0	1	1	1	1	1	1	0

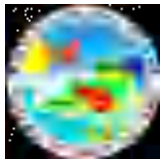

Summary Table Report
California Department of Fish and Wildlife
California Natural Diversity Database

Attachment 9



Name (Scientific/Common)	CNDDB Ranks	Listing Status (Fed/State)	Other Lists	Elev. Range (ft.)	Total EO's	Element Occ. Ranks						Population Status		Presence		
						A	B	C	D	X	U	Historic > 20 yr	Recent <= 20 yr	Extant	Poss. Extirp.	Extirp.
<i>Corynorhinus townsendii</i> Townsend's big-eared bat	G4 S2	None None	BLM_S-Sensitive CDFW_SSC-Species of Special Concern IUCN_LC-Least Concern USFS_S-Sensitive WBWG_H-High Priority	1,000 1,000	635 S:1	0	0	1	0	0	0	0	1	1	0	0
<i>Danaus plexippus pop. 1</i> monarch - California overwintering population	G4T2T3 S2S3	Candidate None	USFS_S-Sensitive	15 40	383 S:2	0	1	1	0	0	0	1	1	2	0	0
<i>Delphinium parryi ssp. blochmaniae</i> dune larkspur	G4T2 S2	None None	Rare Plant Rank - 1B.2		27 S:1	0	0	0	0	0	1	1	0	1	0	0
<i>Delphinium parryi ssp. eastwoodiae</i> Eastwood's larkspur	G4T2 S2	None None	Rare Plant Rank - 1B.2	900 900	15 S:2	0	0	0	0	0	2	2	0	2	0	0
<i>Delphinium umbracolorum</i> umbrella larkspur	G3 S3	None None	Rare Plant Rank - 1B.3 BLM_S-Sensitive USFS_S-Sensitive		95 S:3	0	0	0	0	0	3	3	0	3	0	0
<i>Dudleya abramsii ssp. bettiniae</i> Betty's dudleya	G4T2 S2	None None	Rare Plant Rank - 1B.2 SB_CalBG/RSABG-California/Rancho Santa Ana Botanic Garden	170 820	14 S:7	0	3	1	1	0	2	4	3	7	0	0
<i>Dudleya abramsii ssp. murina</i> mouse-gray dudleya	G4T2 S2	None None	Rare Plant Rank - 1B.3 BLM_S-Sensitive SB_CalBG/RSABG-California/Rancho Santa Ana Botanic Garden	330 1,600	36 S:3	0	0	0	0	0	3	1	2	3	0	0
<i>Dudleya blochmaniae ssp. blochmaniae</i> Blochman's dudleya	G3T2 S2	None None	Rare Plant Rank - 1B.1 SB_CalBG/RSABG-California/Rancho Santa Ana Botanic Garden	30 562	81 S:8	0	1	0	0	0	7	3	5	8	0	0
<i>Elanus leucurus</i> white-tailed kite	G5 S3S4	None None	BLM_S-Sensitive CDFW_FP-Fully Protected IUCN_LC-Least Concern	1,165 1,240	180 S:2	0	2	0	0	0	0	0	2	2	0	0

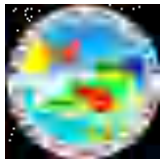

Summary Table Report
California Department of Fish and Wildlife
California Natural Diversity Database

Attachment 9



Name (Scientific/Common)	CNDDB Ranks	Listing Status (Fed/State)	Other Lists	Elev. Range (ft.)	Total EO's	Element Occ. Ranks						Population Status		Presence		
						A	B	C	D	X	U	Historic > 20 yr	Recent <= 20 yr	Extant	Poss. Extirp.	Extirp.
<i>Emys marmorata</i> western pond turtle	G3G4 S3	None None	BLM_S-Sensitive CDFW_SSC-Species of Special Concern IUCN_VU-Vulnerable USFS_S-Sensitive	10 1,464	1404 S:27	2	14	4	0	0	7	10	17	27	0	0
<i>Eriastrum luteum</i> yellow-flowered eriastrum	G2 S2	None None	Rare Plant Rank - 1B.2 BLM_S-Sensitive USFS_S-Sensitive	860 1,900	34 S:12	3	1	1	0	0	7	6	6	12	0	0
<i>Erigeron blochmaniae</i> Blochman's leafy daisy	G2 S2	None None	Rare Plant Rank - 1B.2 BLM_S-Sensitive SB_SBBG-Santa Barbara Botanic Garden	15 15	36 S:1	0	0	1	0	0	0	0	1	1	0	0
<i>Eucyclogobius newberryi</i> tidewater goby	G3 S3	Endangered None	AFS_EN-Endangered IUCN_VU-Vulnerable	20 20	127 S:1	0	0	0	0	0	1	1	0	1	0	0
<i>Extriplex joaquinana</i> San Joaquin spearscale	G2 S2	None None	Rare Plant Rank - 1B.2 BLM_S-Sensitive SB_CalBG/RSABG-California/Rancho Santa Ana Botanic Garden		127 S:1	0	0	0	0	0	1	1	0	1	0	0
<i>Fritillaria ojaiensis</i> Ojai fritillary	G3 S3	None None	Rare Plant Rank - 1B.2 SB_SBBG-Santa Barbara Botanic Garden USFS_S-Sensitive	1,200 1,200	49 S:1	0	0	0	0	0	1	1	0	1	0	0
<i>Helminthoglypta walkeriana</i> Morro shoulderband (=banded dune) snail	G1 S1S2	Threatened None	IUCN_CR-Critically Endangered	10 10	14 S:1	0	1	0	0	0	0	1	0	1	0	0
<i>Horkelia cuneata var. puberula</i> mesa horkelia	G4T1 S1	None None	Rare Plant Rank - 1B.1 USFS_S-Sensitive	820 875	103 S:3	0	0	0	0	0	3	3	0	3	0	0
<i>Horkelia cuneata var. sericea</i> Kellogg's horkelia	G4T1? S1?	None None	Rare Plant Rank - 1B.1 SB_UCSC-UC Santa Cruz USFS_S-Sensitive	600 1,140	58 S:3	0	0	0	0	0	3	3	0	3	0	0
<i>Icaricia icarioides moroensis</i> Morro Bay blue butterfly	G5T2 S2	None None		25 80	12 S:2	0	0	0	0	0	2	2	0	2	0	0
<i>Juncus luciensis</i> Santa Lucia dwarf rush	G3 S3	None None	Rare Plant Rank - 1B.2 BLM_S-Sensitive USFS_S-Sensitive	984 984	37 S:3	0	0	0	0	0	3	3	0	3	0	0

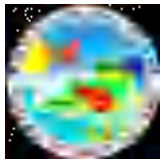

Summary Table Report
California Department of Fish and Wildlife
California Natural Diversity Database

Attachment 9



Name (Scientific/Common)	CNDDDB Ranks	Listing Status (Fed/State)	Other Lists	Elev. Range (ft.)	Total EO's	Element Occ. Ranks						Population Status		Presence		
						A	B	C	D	X	U	Historic > 20 yr	Recent <= 20 yr	Extant	Poss. Extirp.	Extirp.
<i>Layia jonesii</i> Jones' layia	G2 S2	None None	Rare Plant Rank - 1B.2 USFS_S-Sensitive	200 522	25 S:8	0	0	0	0	0	8	3	5	8	0	0
<i>Lepidium jaredii ssp. jaredii</i> Jared's pepper-grass	G2G3T1T2 S1S2	None None	Rare Plant Rank - 1B.2 BLM_S-Sensitive SB_SBBG-Santa Barbara Botanic Garden		12 S:1	0	0	0	0	0	1	1	0	1	0	0
<i>Linderiella occidentalis</i> California linderiella	G2G3 S2S3	None None	IUCN_NT-Near Threatened	968 1,076	508 S:5	0	4	0	0	0	1	0	5	5	0	0
<i>Malacothamnus palmeri var. palmeri</i> Santa Lucia bush-mallow	G3T2Q S2	None None	Rare Plant Rank - 1B.2 SB_CalBG/RSABG-California/Rancho Santa Ana Botanic Garden SB_SBBG-Santa Barbara Botanic Garden USFS_S-Sensitive	850 1,000	10 S:2	0	0	0	0	0	2	2	0	2	0	0
<i>Meconella oregana</i> Oregon meconella	G2G3 S2	None None	Rare Plant Rank - 1B.1	1,200 1,200	9 S:1	0	0	0	0	0	1	1	0	1	0	0
<i>Monardella palmeri</i> Palmer's monardella	G2 S2	None None	Rare Plant Rank - 1B.2 BLM_S-Sensitive USFS_S-Sensitive	1,600 1,600	24 S:2	0	0	0	0	0	2	2	0	2	0	0
<i>Monolopia gracilens</i> woodland woollythreads	G3 S3	None None	Rare Plant Rank - 1B.2		68 S:1	0	0	0	0	0	1	1	0	1	0	0
<i>Navarretia fossalis</i> spreading navarretia	G2 S2	Threatened None	Rare Plant Rank - 1B.1 SB_CalBG/RSABG-California/Rancho Santa Ana Botanic Garden SB_CRES-San Diego Zoo CRES Native Gene Seed Bank	1,100 1,100	82 S:1	0	0	0	0	0	1	1	0	1	0	0
<i>Navarretia nigelliformis ssp. radians</i> shining navarretia	G4T2 S2	None None	Rare Plant Rank - 1B.2 BLM_S-Sensitive	700 1,571	102 S:12	0	0	5	0	0	7	6	6	12	0	0
<i>Neotoma macrotis luciana</i> Monterey dusky-footed woodrat	G5T3 S3	None None	BLM_S-Sensitive CDFW_SSC-Species of Special Concern IUCN_DD-Data Deficient	988 1,700	8 S:3	2	0	0	0	0	1	3	0	3	0	0

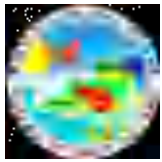

Summary Table Report
California Department of Fish and Wildlife
California Natural Diversity Database

Attachment 9



Name (Scientific/Common)	CNDDB Ranks	Listing Status (Fed/State)	Other Lists	Elev. Range (ft.)	Total EO's	Element Occ. Ranks						Population Status		Presence		
						A	B	C	D	X	U	Historic > 20 yr	Recent <= 20 yr	Extant	Poss. Extirp.	Extirp.
<i>Northern Interior Cypress Forest</i> Northern Interior Cypress Forest	G2 S2.2	None None		2,400 2,400	22 S:1	0	0	0	0	0	1	1	0	1	0	0
<i>Oncorhynchus mykiss irideus pop. 9</i> steelhead - south-central California coast DPS	G5T2Q S2	Threatened None	AFS_TH-Threatened	200 400	41 S:3	0	1	0	0	0	2	3	0	3	0	0
<i>Perognathus inornatus psammophilus</i> Salinas pocket mouse	G2G3T2? S1	None None	CDFW_SSC-Species of Special Concern	1,220 1,225	9 S:3	2	0	0	0	0	1	3	0	3	0	0
<i>Phrynosoma blainvillii</i> coast horned lizard	G3G4 S3S4	None None	BLM_S-Sensitive CDFW_SSC-Species of Special Concern IUCN_LC-Least Concern	25 25	784 S:1	0	1	0	0	0	0	1	0	1	0	0
<i>Plagiobothrys uncinatus</i> hooked popcornflower	G2 S2	None None	Rare Plant Rank - 1B.2 USFS_S-Sensitive	1,780 1,780	14 S:1	0	0	0	0	0	1	1	0	1	0	0
<i>Polyphylla nubila</i> Atascadero June beetle	G1 S1	None None		800 900	4 S:3	0	0	0	0	0	3	3	0	3	0	0
<i>Progne subis</i> purple martin	G5 S3	None None	CDFW_SSC-Species of Special Concern IUCN_LC-Least Concern	915 915	71 S:1	0	1	0	0	0	0	0	1	1	0	0
<i>Pyrgulopsis taylori</i> San Luis Obispo pyrg	G1 S1	None None		880 880	5 S:1	0	0	0	0	0	1	1	0	1	0	0
<i>Rana boylei</i> foothill yellow-legged frog	G3 S3	None Endangered	BLM_S-Sensitive CDFW_SSC-Species of Special Concern IUCN_NT-Near Threatened USFS_S-Sensitive	1,010 1,010	2476 S:1	0	0	0	0	1	0	1	0	0	0	1
<i>Rana draytonii</i> California red-legged frog	G2G3 S2S3	Threatened None	CDFW_SSC-Species of Special Concern IUCN_VU-Vulnerable	10 1,684	1671 S:21	4	10	1	3	1	2	11	10	20	1	0
<i>Senecio aphanactis</i> chaparral ragwort	G3 S2	None None	Rare Plant Rank - 2B.2 SB_CalBG/RSABG-California/Rancho Santa Ana Botanic Garden SB_CRES-San Diego Zoo CRES Native Gene Seed Bank	536 536	98 S:1	0	0	0	0	0	1	0	1	1	0	0

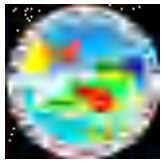

Summary Table Report
California Department of Fish and Wildlife
California Natural Diversity Database

Attachment 9



Name (Scientific/Common)	CNDDB Ranks	Listing Status (Fed/State)	Other Lists	Elev. Range (ft.)	Total EO's	Element Occ. Ranks						Population Status		Presence		
						A	B	C	D	X	U	Historic > 20 yr	Recent <= 20 yr	Extant	Poss. Extirp.	Extirp.
<i>Sidalcea hickmanii</i> ssp. <i>anomala</i> Cuesta Pass checkerbloom	G3T1 S1	None Rare	Rare Plant Rank - 1B.2 SB_CalBG/RSABG-California/Rancho Santa Ana Botanic Garden SB_SBBG-Santa Barbara Botanic Garden USFS_S-Sensitive	2,500 2,500	4 S:1	1	0	0	0	0	0	0	1	1	0	0
<i>Spea hammondi</i> western spadefoot	G2G3 S3	None None	BLM_S-Sensitive CDFW_SSC-Species of Special Concern IUCN_NT-Near Threatened	764 1,591	1422 S:21	2	4	9	2	0	4	9	12	21	0	0
<i>Streptanthus albidus</i> ssp. <i>peramoenus</i> most beautiful jewelflower	G2T2 S2	None None	Rare Plant Rank - 1B.2 SB_CalBG/RSABG-California/Rancho Santa Ana Botanic Garden SB_UCBG-UC Botanical Garden at Berkeley USFS_S-Sensitive		103 S:2	0	0	0	0	0	2	2	0	2	0	0
<i>Suaeda californica</i> California seablite	G1 S1	Endangered None	Rare Plant Rank - 1B.1		18 S:1	0	0	0	1	0	0	0	1	1	0	0
<i>Taricha torosa</i> Coast Range newt	G4 S4	None None	CDFW_SSC-Species of Special Concern	965 1,700	88 S:9	1	3	0	1	0	4	3	6	9	0	0
<i>Taxidea taxus</i> American badger	G5 S3	None None	CDFW_SSC-Species of Special Concern IUCN_LC-Least Concern	670 1,055	594 S:16	14	2	0	0	0	0	14	2	16	0	0
<i>Trimerotropis occulens</i> Lompoc grasshopper	G1G2 S1S2	None None	IUCN_EN-Endangered	900 900	8 S:1	0	0	0	0	1	0	1	0	0	1	0
<i>Valley Oak Woodland</i> Valley Oak Woodland	G3 S2.1	None None		1,060 2,000	91 S:6	0	0	0	0	0	6	6	0	6	0	0
<i>Vireo bellii pusillus</i> least Bell's vireo	G5T2 S2	Endangered Endangered	IUCN_NT-Near Threatened NABCI_YWL-Yellow Watch List	660 710	503 S:2	1	0	0	0	0	1	1	1	2	0	0

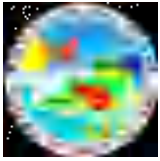

Summary Table Report
California Department of Fish and Wildlife
California Natural Diversity Database

Attachment 9



Name (Scientific/Common)	CNDDB Ranks	Listing Status (Fed/State)	Other Lists	Elev. Range (ft.)	Total EO's	Element Occ. Ranks						Population Status		Presence		
						A	B	C	D	X	U	Historic > 20 yr	Recent <= 20 yr	Extant	Poss. Extirp.	Extirp.
<i>Vulpes macrotis mutica</i> San Joaquin kit fox	G4T2 S2	Endangered Threatened		658 1,049	1020 S:17	2	0	0	1	0	14	16	1	17	0	0

CULTURAL RESOURCES INVENTORY SURVEY Attachment 9
AT 2805 THEATRE DRIVE, PASO ROBLES,
SAN LUIS OBISPO COUNTY, CALIFORNIA

[APN: 009-851-022]

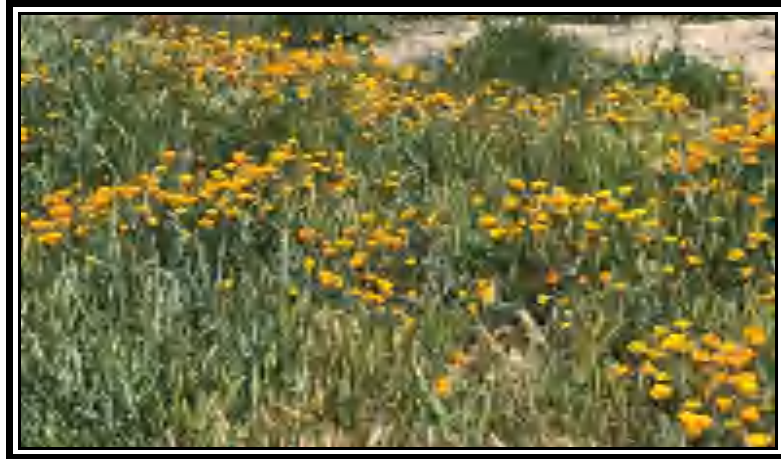

Prepared for:

Coast Counties Peterbilt
1740 No. 4th Street
San Jose, CA 95116

Prepared by:

Nancy Farrell
Cultural Resource Management Services
829 Paso Robles Street
Paso Robles, California 93446

Templeton 7.5' Quadrangle

May, 2022



CRMS Project No. 56-2027

INTRODUCTION

At the request of Craig Archer, Cultural Resource Management Services (CRMS) has conducted a literature and records search and intensive archaeological survey of a parcel at 2805 Theatre Drive, Paso Robles. This will be the new business location of the Central Coast Peterbilt dealership. The purpose of this investigation is to identify any cultural resources present on the parcel that may be affected by the proposed construction. This work was completed in order to comply with the requirements of the California Environmental Quality Act (CEQA) and the County of San Luis Obispo (Figure 1, 2, and 3).

CEQA requires lead agencies to evaluate proposed projects for their potential to impact archaeological resources (Public Resources Code Section 21082, 21083.2, and 21084.1, and California Code of Regulations 15064.5). According to the CEQA Guidelines, "historical resources" include buildings, structures, objects, districts, or sites that may possess prehistoric or historical archaeological, architectural, cultural, or scientific importance. CEQA states that if a project will have a significant effect on important cultural resources, then alternative plans or mitigation measures need to be developed. were conducted to identify and evaluate any significant prehistoric or historic cultural resources that might be impacted by the proposed construction (Exhibit A).

In addition, as part of an early participation notice, letters were sent to Native American tribes, organizations and individuals. The list of recipients was provided by the Native American Heritage Commission (NAHC), and is comprised of those groups and individuals thought to have a cultural interest in this area, notifying them of the proposed project, inviting them to consult, and requesting information or concerns regarding the proposed project. A Sacred Lands Search was conducted at the Native American Heritage Commission (NAHC). Concurrent with that search, Native Americans and Native American groups cited by the NAHC were contacted. There was one responses to the letters written, noted specifically in Exhibit B.

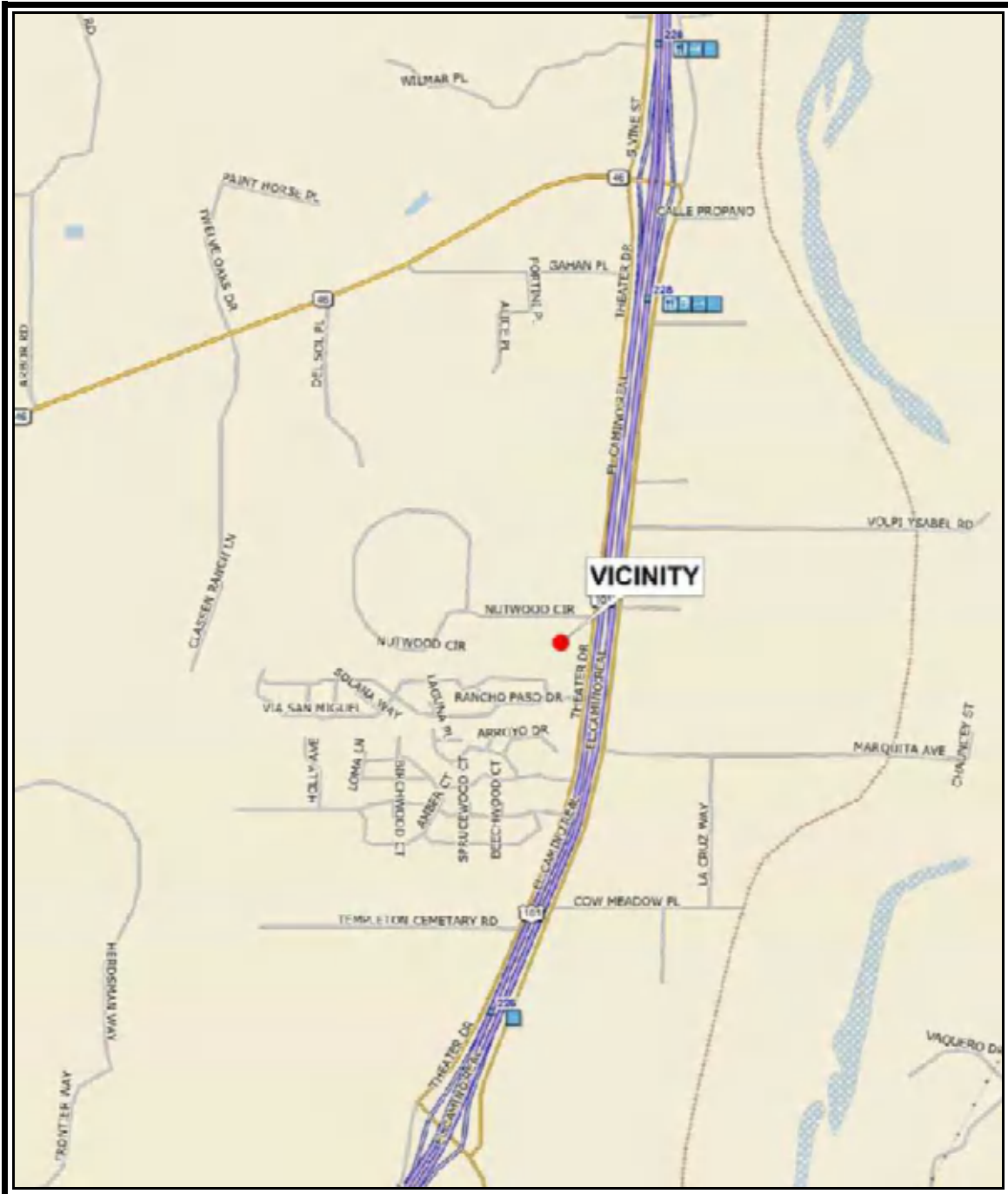

Figure 1: Vicinity Map (No Scale)

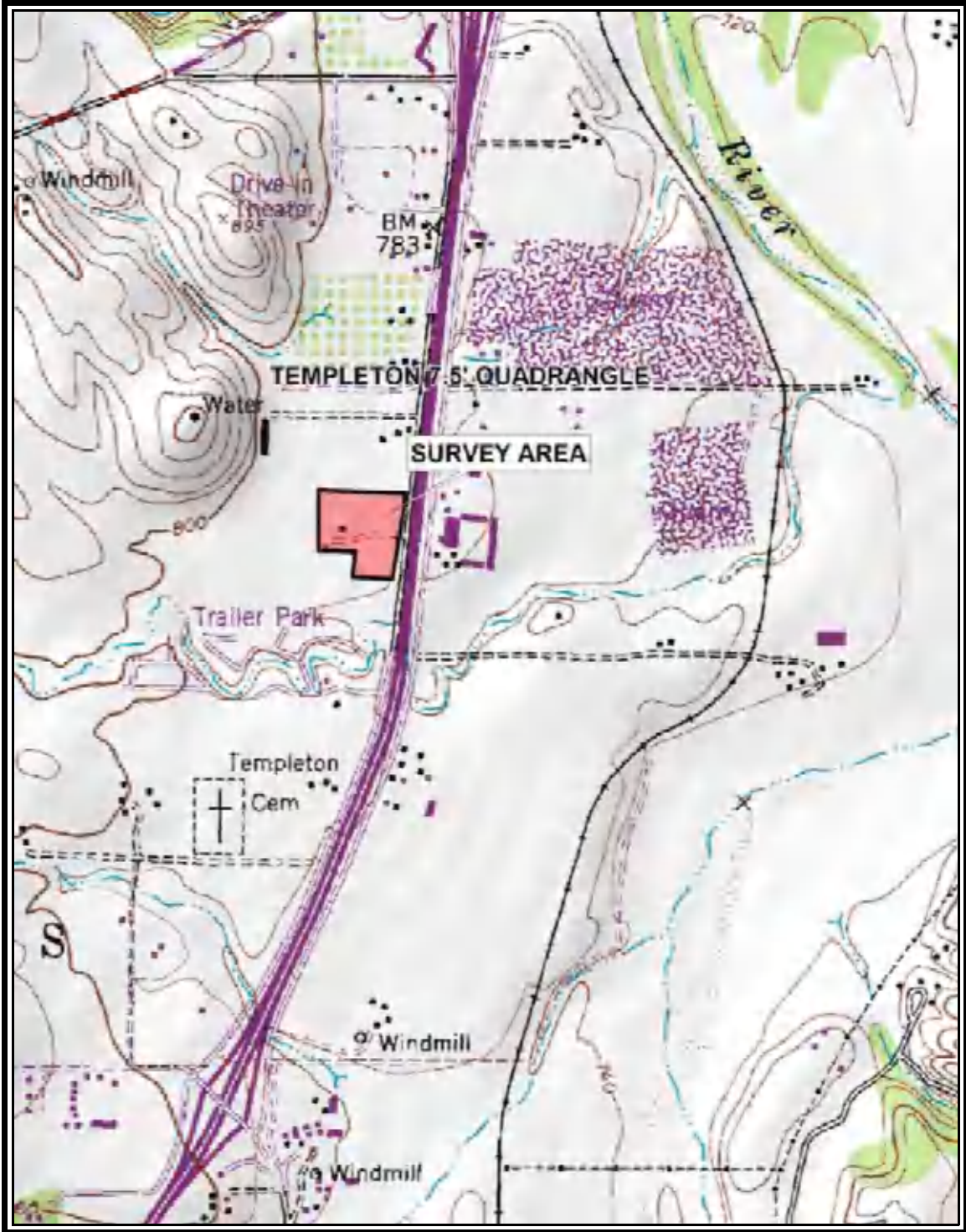

Figure 2: Portion of USGS 7.5' Quadrangle-Templeton, CA

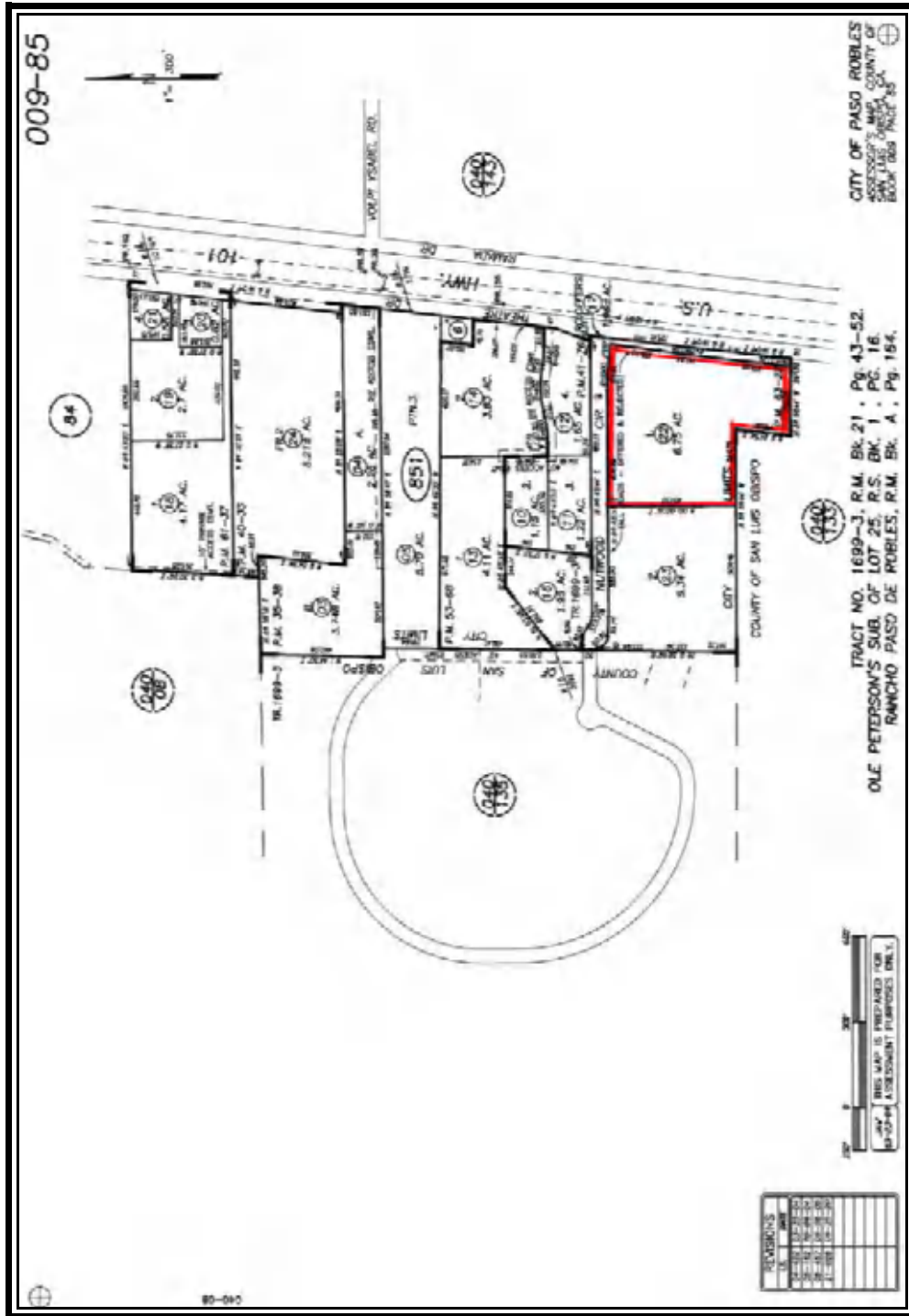

Figure 3: Assessor's Parcel Map-Parcel Shown In Red Outline

ENVIRONMENTAL CONTEXT

The project area consists of a ± 7 acre property at the southern corporate limit of the City of El Paso de Robles, California, west of Highway 101 (Figure 1). Paso Robles lies on a terrace above the western bank of the Salinas River that grades into the hilly flanks of the Santa Lucia Range.

Climate

The weather pattern is characterized by hot, dry summers and cool, moist winters. Every several years, extreme frosts occur during winter months, but generally the area experiences 300 to 325 frost-free days per year. Such a setting is eminently suitable for human habitation.

Geology and Pedology

The Paso Robles area presents a complex geologic picture, underlain by the 4.3 million year old Paso Robles Formation. Sandstones, siltstone, diatomite and conglomerates are characteristic rocks. Beds of fossil pecten and oyster shells from the 5-7 million year old Santa Margarita Formation are also present in some locations (Chipping 1987:VIII-7). The grey-brown soil of the project area is Lockwood shaly loam (Lindsey 1983: 45), deep well-drained soils that formed in material weathered from sedimentary rocks.

Water Sources

Annual rainfall ranges from 12 to 20 inches. Today, the Salinas River, a half-mile to the east, flows at the surface only during seasons of heavy rainfall, but the river flow was more abundant and regular during the time of prehistoric human occupation of the area. The surface flow has been reduced to a minimum in recent years by the many municipal and private wells which draw water from the river for residential and agricultural use, as well as the construction of the Santa Margarita Dam in the early 1940s. There are natural springs in the area, both warm sulphur springs and fresh water (Chapman *et al.* 1980: 15).

Vegetation

The regional vegetation is melange of oak savanna, oak woodland and chaparral plant communities with a riparian component. Commonly occurring species are: Valley

Attachment 9

oak (*Quercus lobata*), interior live oak (*Quercus wizlizenii*), chamise (*Adenostoma fasciculatum*), California lilac (*Ceanothus spp.*) and coyote brush (*Baccharis pilularis*). Along the creeks is a riparian community where western sycamore (*Platanus racemosa*), willow (*Salix sp.*), cottonwood (*Populus fremontii*), White alder (*Alnus Rhombifolia*), Poison oak (*Toxicodendron diversilobum*), Blackberry (*Rubus ursinus*), Poison hemlock (*Conium maculatum*), and elderberry (*Sambucus mexicana*) are common. On the project property, vegetation now consists primarily of a few specimens of valley oak, California poppies and a variety of weedy forbs and grasses.

Fauna

Fauna commonly occurring in the surrounding area include black-tailed deer (*Odocoileus hemionus columbianus*), coyote (*Canis latrans*), black-tailed jackrabbit (*Lepus californicus*), cottontail rabbit (*Sylvilagus spp.*), black bear (*Ursus americanus*) and historically, grizzly bear (*Ursus horribilis*) and tule elk (*Cervus elaphus nannoides*). A number of ground squirrels (*Spermophilus spp.*), the western gray squirrel (*Sciurus griseus*), gophers (*Thomomys spp.*), mice (*Microtus spp.* and *Peromyscus spp.*), and a variety of reptiles and amphibians are also present.

Common birds in the area include red-tailed hawk (*Buteo jamaicensis*), California scrub jay (*Aphelocoma coerulescens*), mourning dove (*Zenaida macroura*), western meadowlark (*Sturnella neglecta*), mockingbird (*Mimus polyglottos*) and turkey vulture (*Cathartes aura*), acorn woodpecker (*Melanerpes formicivorus*), and valley quail (*Lophortyx californicus*).

CULTURAL BACKGROUND

Archaeological Background

Archaeological evidence indicates that the San Luis Obispo County region was occupied as early as 8000-9000 years ago, as indicated by radiocarbon dates from excavations at Diablo Canyon (Greenwood 1972), Edna Valley (Fitzgerald 2000), Cambria (Gibson 1979) and Paso Robles (Stevens *et al.* 2004). The cultural history of this region has until recently been placed within the sequence that has been defined for the Santa Barbara region, where far more archaeological investigations had taken place. The first regional chronology was proposed by D.B. Rogers (1929) and was based on his

Attachment 9

excavation of coastal sites around Santa Barbara. This three-part sequence of Early Oak Grove or Millingstone Culture, Intermediate or Hunting People and a late Canaliño Culture is still considered generally valid in terms of broad cultural patterns (Fitzgerald and Jones 1998).

Researchers on the Central Coast have continued to refine the chronological framework and several alternative schemes have been proposed, primarily based on sites in the Central Valley, Central Coast and Channel Islands (*cf.* Moratto 1984: 125; King 1990; Erlandson and Jones, 2002; Jones *et al.* 2007). The following chronology for the San Luis Obispo area builds on this work and incorporates extensive investigations carried out on the Pecho Coast, south of San Luis Obispo (Jones and Coddling 2019). All dates are radiocarbon calibrated dates:

<i>Paleoindian</i>	<i>10,000 BCE - 8350 BCE</i>
<i>Millingstone/ Lower Archaic</i>	<i>8350 BCE - 3500 BCE</i>
<i>Early</i>	<i>3500 BCE - 600 BCE</i>
<i>Middle</i>	<i>600 BCE - 1000 CE</i>
<i>Middle/Late Transition</i>	<i>1000 CE- 1230 CE</i>
<i>Late</i>	<i>1230 CE - 1769 CE</i>
<i>Mission Period</i>	<i>1769 CE - 1830 CE</i>

These periods are based upon shifts in technology that relate to the type and variety of foods consumed, methods of procurement, and social structure. The earliest periods were a time of hunting and gathering, with an emphasis on seed collecting and processing. The tool kit for these periods shows an emphasis on milling equipment and crude cores yielding flaked stone tools. An increased reliance on fishing (evidenced by fishhooks), and on acorns as a dietary staple (mortars and pestles), was indicated later by the addition of new tools.

Paleoindian (10,000 BCE - 8350 BCE)

Excavations on the northern Channel Islands have yielded radiocarbon dates as early as 12,500 years ago (Erlandson and Braje 2011). There is still very limited information for the Paleoindian period in the Central Coast mainland region.

Millingstone Period (8350 BC-3500 BC)

Attachment 9

More substantive archaeological evidence exists for the Millingstone Period, as evidenced by radiocarbon dates from excavations conducted at Diablo Canyon (Greenwood 1972), Cambria (Gibson 1979) Edna Valley (Fitzgerald *et. al* 1998) and Paso Robles (Stevens *et.al* 2004). It was during this period that permanent settlements with associated cemeteries were established. This basic adaptation persisted until about 3500 BC and was characterized by milling slabs, manos (handstones), rather crude cobble tools and a high density of marine shellfish remains on the coast. Collection of seeds appears to have been important for diet.

Early Period (3500 BCE – 600 BCE)

Along the coast and in interior areas, the Early period is marked by the appearance of mortars and pestles and contracting-stemmed projectile points (Jones 1993). Other artifacts found with Early period occupations are also found in Millingstone period sites, including Olivella (*Callianax biplicata*) class L beads, large side-notched projectile points, and milling slabs and handstones. Large projectile points and stone knives are indicative of hunting activity. Milling implements consisting of manos and metates were evidence of the processing of seeds, and possibly vegetable foods, dried meats, and fish. Greater numbers of sites are known from the Early period, possibly signaling a population increase. The end of this period is marked by changes in technology with the decrease of manos and metates, a shift in the settlement pattern, and alterations in ornamental style.

Middle Period (600 BCE – 1000 CE)

Mortars and pestles become larger and more common during this period and small seeds become less important as a staple. Exotic products are adopted. This period heralds the advent of social and political alliances and economic networks to regulate food supplies and their distribution in order to alleviate conditions resulting from regional fluctuations in the harvest. Some villages grew larger and less defensive in nature as populations were integrated into larger political units. The end of this period is marked by dramatic changes in economic, social, and political conditions, evidenced by new habitation sites and larger coastal fishing communities.

The Middle period is well represented at recorded sites along the central coast and increasingly in interior regions as well. The types of artifacts found in Middle period occupations are similar to those from the Early period although a larger number

Attachment 9

of bone implements and bead types are known and projectile points tend to be contracting-stemmed types instead of side-notched and square-stemmed (Olsen and Payen 1969; Bennyhoff and Hughes 1987; Jones and Waugh 1995). Excavations at Fort Hunter-Liggett have shown that Middle period occupations in that area resemble those found along the coast (Jones and Haney 1997).

Middle/Late Transition Period (1000 CE - 1230 CE)

Around 1,000 AD a 300-year period of warmer temperatures and drier climate, the Medieval Climatic Anomaly, caused adverse environmental conditions, particularly intermittent droughts (Raab and Larson 1997). During the Late Period, terrestrial resource production is thought to have decreased significantly, while adaptive responses involving technology and social complexity evolved. Characteristic artifacts include curved shell fishhooks, mortars with attached basket hopper, contracting-stemmed and double side-notched projectile points. The bow and arrow was introduced.

Late Period (1230 CE - 1769 CE)

This period is marked by a more mobile, dispersed settlement pattern than earlier periods (Jones *et al.* 2015: 15), an increasing dependence on acorns and other storable commodities, and a general diversification of the marine and terrestrial foods consumed. Late period assemblages from the interior south coast ranges are distinguished by a suite of new bead types, small side-notched and triangular arrow points, and hopper mortars as well as many artifact types found in earlier periods (Olsen and Payen 1969). At Fort Hunter Liggett, Late period occupations also included small arrow points, new bead types, as well as bedrock mortars and unshaped pestles (Jones 2000; Haney *et al.* 2002). The Late period assemblages from a wide area of the central coast and interior regions appear superficially similar, but this was probably a time of continued cultural differentiation due to higher population densities.

Mission Period (1769 CE - 1830 CE)

Glass trade beads, square nails and bottle glass begin to appear in the archaeological matrix (Meighan 1979; Moratto 1984: 273).

Attachment 9

Ethnographic Overview

At the time of European contact, the Paso Robles region was primarily occupied by a branch of the northern-most Chumash, the Obispoño (Kroeber 1925). This group inhabited coastal and inland areas between Malibu and the vicinity of San Simeon (Kroeber 1925; Gibson 1983). Also present in the region historically were the Miguieleño Salinan (Greenwood 1978). The Salinan were bordered by the Esselen and Costanoan to the north, Yokuts to the east and the Chumash to the south. Examination of mission records reveals that members of the Salinan Nation inter-married into the northern portion of San Luis Obispo County, including the Paso Robles area. The exact boundary of these two groups has not been well established and is the subject of continuing research on the part of ethno-historians, archaeologists, and some Salinan and Chumash descendants.

The economies of the Salinan and the Chumash, as observed at the time of European contact, were based upon an annual cycle of gathering and hunting (Geiger and Meighan 1976). Vegetal foods, especially acorns, provided the bulk of the diet. Acorns were stored in large willow-twig granaries until needed, then ground in a stone mortar. The tannic acid present in the acorn meal was leached out with water, and the result was cooked into a gruel. Other important plant foods included wild grass and other hard seeds, roots and corms, and various fruits and berries. Major animal foods included an assortment of terrestrial mammals, marine and freshwater fish, shellfish, birds, as well as reptiles and insects. It is unclear to what extent people living inland ventured to the coast and vice versa, but it is likely that people were mobile enough to take advantage of plant and animal foods when and where they occurred. Diets would have varied from season to season, and from year to year, depending on what was available and accessible.

Stone, bone, wood, plant fibers and shell all provided materials for the production of tools. Hunting of animals and birds was accomplished with snares, traps, spears, darts, and the during the Late Period, bow and arrow. Stone work included projectile points, knives, scrapers, choppers and awls. Pecked and ground stone objects included bowl mortars, pestles, metates, basket mortars, stone bowls, notched pebble net sinkers, and steatite arrow shaft straighteners. Ornaments were made of steatite and serpentine. Bone and shell tools were also manufactured; especially bone awls and C-

Attachment 9

shaped fishhooks. Shell beads of mussel and abalone were the basis of the Salinan "currency", with value being assigned based on the color or the shell (Hester 1978: 502).

Historic Overview

European contact in the San Luis Obispo County region may have begun as early as 1587 with the visit of Pedro de Unamuno to Morro Bay, although some scholars have questioned this based on the ambiguity of Unamuno's descriptions (Mathes 1968). A visit in 1595 by Sebastian Rodriguez Cermeño is better documented (Wagner 1924). The earliest well-documented descriptions come from accounts by members of Gaspar de Portola's land expedition, which passed through the region in 1769 (Squibb 1984). No large villages, such as those seen along the Santa Barbara channel, were reported by early travelers in the San Luis Obispo region.

Permanent Spanish settlement of the region began with the founding of Mission San Antonia de Padua (near King City) in 1771 and San Luis Obispo de Tolosa (in San Luis Obispo) in 1772. Twenty-five years later, Mission San Miguel Archangel was founded in the heart of southern Salinan territory. The mission properties of San Miguel mission were extensive and included an outlying rancho station, Las Gallinas, near present day Paso Robles (Ohles 1997).

As elsewhere, induction into the mission system had a devastating effect on the local inhabitants, requiring them to live and work at the mission and to a great extent abandon their former lifeways. The inadvertent introduction of European diseases, the consequent high mortality rate, and the pressure of overwhelming social change decimated the population. By 1805, most native villages had been abandoned, and the populace had either fled or moved into the mission system (Gibson 1983). The natives who had survived the Spanish colonization period, went on to build and staff the rancheros of the Mexican and American periods which followed. By the beginning of the 20th Century, the Chumash and Salinan had been integrated into American society (Gibson 1983; King 1984, 1990).

In 1822, Mexico attained independence of Spain and California became a Mexican territory. The Secularization Act, passed by the Mexican congress in 1833, provided for the immediate break-up of the missions and the transfer of mission lands to settlers and Indians. Work toward this end began in 1834 under Governor Figueroa.

Attachment 9

Grants were made to individuals by the governor on the recommendation of the local *alcalde* of the Mission (Shumway 2007). During the years from 1840 to 1846, a series of land grants were made from the lands of Mission San Miguel by the governors of Mexican California. Most of these were used for grazing huge cattle herds. Even after the acquisition of California by the United States the ranchos continued to thrive until the drought of 1863 - 1864. This drought was ruinous to many of the ranchos. Tens of thousands of acres changes hands as lands sold for less than their assessed value (Angel 1883; Morrison & Haydon 1917). The new owners were most often North Americans who arrived on the heels of the drought as land prices plummeted.

The project area was a portion of the 26,000 acre rancho El Paso de los Robles, granted May 12, 1844 to Pedro Navarez by Mexican Governor Manuel Micheltoena. In 1848 the Treaty of Guadalupe Hidalgo marked an end to the Mexican American war and California became a territory of the United States. Statehood was attained in 1850 and in 1851 the Land Act, passed by Congress, meant that the rancheros now had to prove ownership of their land. A patent on the El Paso de los Robles was obtained July 20, 1866 by Petronillo Rios. Prior to the patent, however, the parcel had been sold in two separate transactions, first to Daniel and James Blackburn on September 21, 1858. The second portion was sold July 9, 1861 to Lazarus Godchaux. They immediately began making improvements to the hot sulphur springs which had been used by local inhabitants for generations. The location had long been a rest stop for travelers on the El Camino Real. In 1864 the El Paso de Robles Hotel with attendant mineral hot spring bathhouse, was built. By the 1870s, the Paso Robles Hot Springs was a well known destination for people seeking the famous curative powers of the springs (Sawyer 1915).

The West Coast Land Co. was incorporated on March 27, 1886. The immediate objective was to develop 64,000 acres of land, comprised of the ranchos Santa Ysabel, El Paso de Robles, Eureka, and the unsold portion of Huer Huero that had been purchase over the preceding decade. The purchases were based upon the expectation that the Southern Pacific Railroad coastal line between San Francisco and Los Angeles through San Luis Obispo County would bring prosperity to the region (Nicholson 1980). A town plan for Paso Robles, on the western side of the Salinas River, was commissioned, and on November 17, 1886, two weeks after the first train arrived in "town" a Grand Auction was held, resulting in the sale of 228 lots. The town plan was completed by 1887 and the town was incorporated as a city in 1889. The trickle of settlers became a

Attachment 9

flood and Paso Robles became a major export center for cattle, grain, dairy products, stone fruit, walnuts, and almonds. Throughout the later part of the nineteenth and the twentieth century, the economy of the Paso Robles region was largely agricultural. Cattle ranches, dairies, almond and other fruit orchards, and large tracts devoted to dry land grain production comprised the rural landscape. This resulted in the clearing of much of the Oak woodland, including the present project area (Rossi 1979: 258). During the mid twentieth century, Paso Robles was known as "The Almond Capital of the World." Much of the region around Paso Robles

In 1882, York Mountain Vineyard opened, eventually becoming one of the first bonded wineries on the Central Coast. Agriculture has continued to be the mainstay of the region up to the present, with increasing emphasis on viticulture and wine-making. The proliferation of wineries in the last 30 years has also lead to tourism once again becoming a major component of the local economy.

MAP AND RECORDS SEARCH RESULTS

Prior to the field survey, a records and literature search was conducted at the Central Coast Information Center, Museum of Natural History, Santa Barbara, which is the regional clearinghouse for archaeological site information for San Luis Obispo County under agreement with the California Office of Historic Preservation (OHP). The search also included inventories for the State Historic Property Data Files, National Register of Historic Places, National Register of Determined Eligible Properties, California Historical Landmarks, California Points of Historic Interest, California OHP Archaeological Determinations of Eligibility, and the CalTrans State and Local Bridge Surveys.

Seven cultural resource studies have been conducted within a 1/4 mile radius of the project area (Bonner 2004; Clift and Farrell 2001; Farrell 1998; Gibson 1973; Girado and Orfila 2008; Singer 2004, 2006). No prehistoric archaeological sites or historic properties have been identified within the same radius.

SUMMARY OF NATIVE AMERICAN OUTREACH

A letter was sent on March 6, 2022, to the Project Analyst at the Native American Heritage Commission. The letter explained the proposed project and asked him to conduct a Sacred Lands Search and forward to CRMS any names and addresses of those who may have knowledge of cultural resources within the study area, or who would like to comment on the project.

On April 24, 2022 a letter dated the same day, was received from Cody Campagne, Project Analyst, indicating that the Sacred Lands Search conducted at the Native American Heritage Commission (NAHC) yielded no evidence of Sacred Lands with the project. A list of interested Native American individuals and groups was included. Letters, explaining the project and soliciting comments were sent to each of the Native Americans and groups listed (Exhibit B). On April 25, 2022, letters were written to the Native Americans and groups listed by the NAHC explaining the project, and asking for their comments.

RESULTS OF FIELD INVESTIGATION

A field reconnaissance of the project area was made on April 20, 2022 by Nancy Farrell and Ron Rose of CRMS. The entire surface was inspected by walking parallel transects at two meter intervals. Mineral soil visibility was variable but generally good (50%). Additionally, the abundant ground burrow spoil piles provided additional visibility. No evidence of prehistoric or historic artifacts, features, or other indications of significant cultural resources were found during the survey. (Figure 4, 5, 6, 7, and 8). There was evidence of a previous water hookup and a telephone pole, no evidence of a building structure was found. An examination of aerial photos from the 1970s yielded no additional information. There was a sewer manhole. A check with the City Wastewater Treatment Department showed no sewer hookup in that location. Further examination with the cover removed showed that the manhole was never developed, but abandoned. Apparently a previous property owner had some plans for future development. Also on the property is a fenced detention basin approximately 80 feet square. This detention may be used for the present development or abandoned.

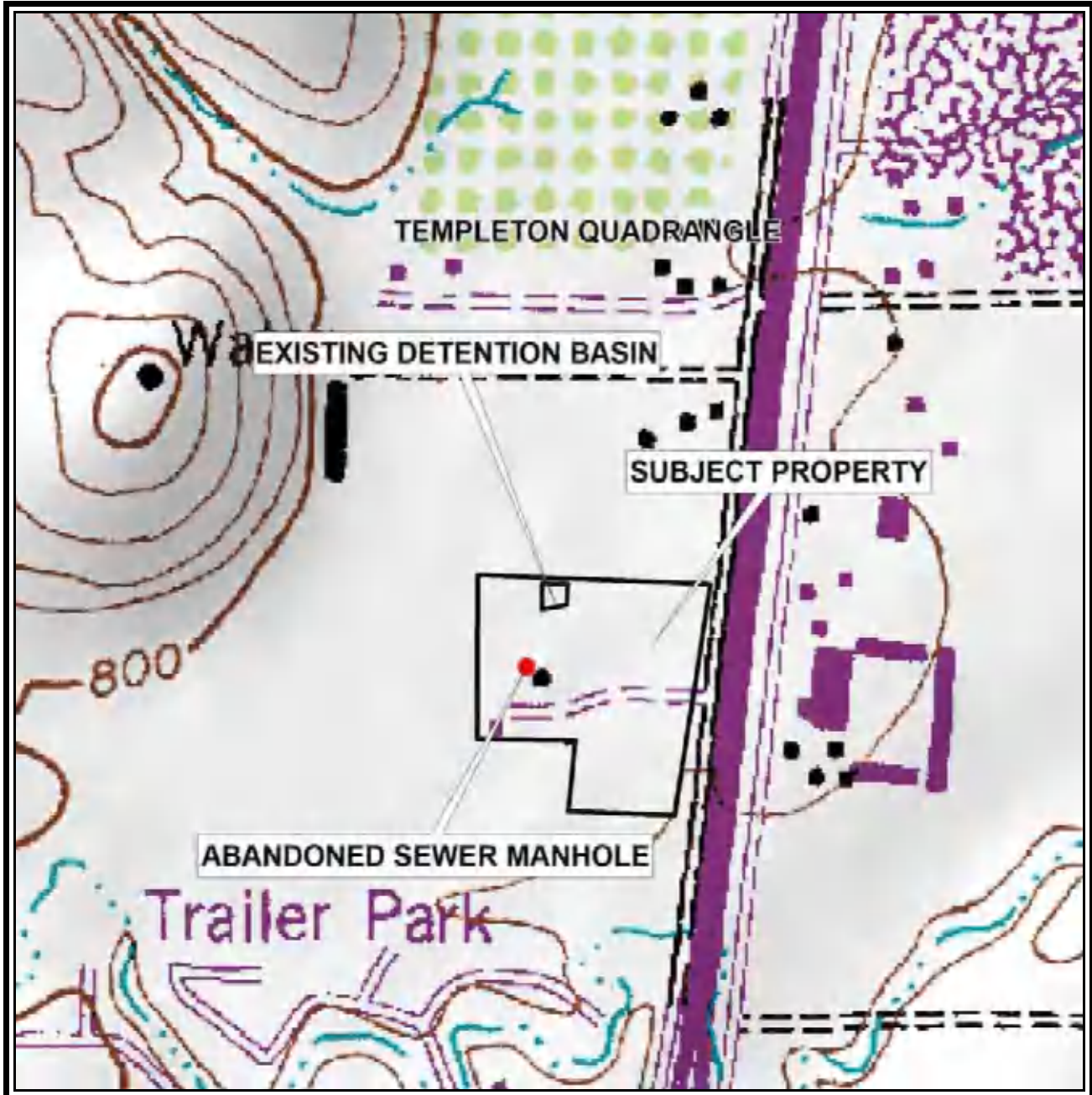

Figure 4: Portion of Templeton USGS Quadrangle. Red Dot Is Location of Abandoned Manhole. Black Polygon Is Location of Existing Detention Basin. 1979 Quadrangle Shows A Structure of Some Kind Indicated In Black Next To Abandoned Manhole.



Figure 5: Overview of Subject Parcel-View To East



Figure 6: Overview of Subject Parcel-View Northeast

Attachment 9



Figure 7: Overview of Subject Parcel-View To South



Figure 8: Overview of Subject Property-View To West

CONCLUSION AND RECOMMENDATIONS

Since no evidence of significant cultural resources was located on the subject property, no further archaeological investigations are recommended at this time. While it is unlikely that subsurface remains are present, the nature of surface survey does not preclude the possible existence of such remains. If prehistoric or historic cultural materials are encountered during any phase of property grading or development the work should be halted until a qualified archaeologist can make an assessment of the resources and proper mitigation measures be formulated, if necessary.

Attachment 9

REFERENCES CITED

- Angel, Myron
1883 *History of San Luis Obispo County, California*. Thompson & West, Oakland. Facsimile
Reproduction, Valley Publishers, Fresno. 1979.
- Bennyhoff, J. A., and R. E. Hughes
1987 Shell Beads and Ornament Exchange Networks Between California and the Western
Great Basin. *American Museum of Natural History Anthropological Papers* 64 (2).
- Bonner, W.
2004 Cultural Resource Records Search and Site Visit for Cingulat Telecommunications
Facility Candidate VY-553-01 (Hwy 101 and 46). Michael Brandman Associates
- Brown, A. K.
1967 The Aboriginal Population of the Santa Barbara Channel. *University of California
Archaeological Survey Reports* 69: 1-99. Berkeley.
- Chapman, Rodger, Gordon W. Chase, and Les G. Youngs
1980 Geophysical Survey, Paso Robles Geothermal Area, California Part of the Resource
Assessment of Low-and Moderate-Temperature Geothermal Resource Areas in
California. Submitted to U.S. Department of Energy, Division of Geothermal Energy.
California Department of Conservation, Division of Mines and Conservation.
- Chipping, David
1987 *The Geology of San Luis Obispo County: A Brief Description and Field Guide*.
- Clift, Gregory and Nancy Farrell
2001 Phase 1 Archaeological Inventory for the Graff Groundwater well site near Ramada
Drive, Templeton, San Luis Obispo county, California. Cultural Resource Management
Services.
- Dart, Louisiana Clayton
1978 *Vignettes of History in San Luis Obispo County*. Mission Federal Savings. San Luis
Obispo, California.
- Erlandson, Jon and Todd Braje
2011 From Asia to the Americas by Boat? Paleogeography, paleoecology, and stemmed
points of the Northwest Pacific. *Quaternary International* 239: 28-37.
- Erlandson Jon M. and Terry L. Jones, editors
2002 *Catalysts to Complexity, Late Holocene Societies of the California Coast*. Perspectives in
California Archaeology, Volume 6. Cotsen Institute of Archaeology, UCLA.
- Farrell, Nancy
1998 Phase 1 Cultural Resources Survey of the Boatman Property (APN 009-851-007 & 009)
Paso Robles, California. Cultural Resources Management Services

Attachment 9

Fitzgerald, Richard T.

2000 Cross Creek: An Early Holocene/Millingstone Site. *California State Water Project, Coastal Branch Series Paper No. 12*. San Luis Obispo County Archaeological Society.

Fitzgerald, Richard T. and Terry L. Jones

1998 Interpretive Synthesis of Subsurface Archaeological Investigations for the Coastal Branch Phase II Project. Appendix G in *Archaeological Data Recovery at CA-SLO-1797, the Cross Creek Site, San Luis Obispo County, California, Coastal Branch, Phase II Project*. Submitted to California Department of Water Resources. Garcia and Associates, San Anselmo.

Geiger, M. and Clement Meighan

1976 *As the Padres Saw Them: California Indian Life and Customs as Reported by the Franciscan Missionaries, 1813 -1815*. Santa Barbara Mission Archive Library. Santa Barbara.

Gibson, Robert O.

1973 Archaeological Element of Environmental Impact Report for the Proposed Development of the Durand Property, San Luis Obispo County, California.

1979 Preliminary Inventory and Assessment of Indian Cultural Resources at Lodge Hill, Cambria, San Luis Obispo County, California. On file at the Central Coastal Information Center.

1981 Archaeological Element of Environmental Impact Report for the Holsted Subdivision, Parcel Map CO-80-24 Paso Robles, CA.

1983 Ethnogeography of the Salinan People: A Systems Approach. Master's Thesis, California State University, Hayward.

1990 Results of Phase One Archaeological Surface Survey on Tract 1865, Paso Robles.

Girado, Amy and Rebecca Orfila

2008 Archaeological and Historical Investigations of the CAL FIRE Paso Robles Fire Station, San Luis Obispo, California. Center for Archeological Research.

Greenwood, Roberta S.

1972 *9000 Years of Prehistory at Diablo Canyon, San Luis Obispo County, California*. San Luis Obispo County Archaeological Society Occasional Paper 2, San Luis Obispo.

1978 Obispeño and Purisimeño Chumash. In *Handbook of North American Indians, Vol. 8, California*. Smithsonian Institution, Washington, DC.

Haney, Jefferson W, Terry L. Jones, and Jennifer M. Farquar

2002 Phase II Archaeological Investigation of CA-MNT-879 Fort Hunter Liggett, Monterey County, California. Report submitted to U.S. Army Corps of Engineers, Sacramento District.

Hester, Thomas Roy

1978 Salinan. In *Handbook of North American Indians, Vol. 8, California*. Smithsonian Institution, Washington DC.

Jones, Deborah, Terry Jones, Kacey Hadick, William Hildebrandt & Patricia Mikkelsen

2015 Archaeological Investigations for the Los Osos Wastewater Project, San Luis Obispo County, California.

Attachment 9

- Jones, Terry L.
1993 Big Sur: A Keystone in Central California Cultural History. *Pacific Coast Archaeological Society Quarterly* 29(1):1-78.
- 2000 Archaeological Evaluations at CA-MNT-237 and CA-MNT-519, Fort Hunter- Liggett, Monterey County, California. Report submitted to U.S. Army Corps of Engineers, Sacramento District.
- Jones Terry L. and Brian Coddling
2019 *Foragers on America's Western Edge, The Archaeology of California's Pecho Coast*. The University of Utah Press, Salt Lake City.
- Jones, Terry L., and Jefferson W. Haney
1997 Archaeological Evaluation of CA-MNT-521, Fort Hunter Liggett, Monterey County, California. Report submitted to U.S. Army Corps of Engineers, Sacramento District.
- Jones, Terry, Nathan Stevens, Debbie Jones, Richard Fitzgerald, and Mark Hylkema.
2007 The Central Coast: A Midlatitude Milieu. In *California Prehistory: Colonization, Culture, and Complexity*, edited by Terry Jones and Kathryn Klar. AltaMira Press in cooperation with the Society for California Archaeology, Plymouth, United Kingdom.
- Jones, Terry L. and Georgie Waugh
1995 *Central California Prehistory: A View from Little Pico Creek. Perspectives in California Archaeology, Vol. 3*. Institute of Archaeology, University of California, Los Angeles.
- Jones, Terry, Nathan Stevens, Deborah A. Jones, Richard T. Fitzgerald and Mark Hylkema
2007 The Central Coast: A Midlatitude Milieu , in *California Prehistory, Colonization, Culture and Complexity*, edited by Terry L. Jones and Kathryn A. Klar, pp 125-146. Altamira Press, Lanhma, MD.
- Jones, Terry L. and Georgie Waugh
1995 *Central California Prehistory: A View from Little Pico Creek. Perspectives in California Archaeology, Vol. 3*. Institute of Archaeology, University of California, Los Angeles.
- King, Chester
1984 Appendix I: Ethnohistoric Background. In *Archaeological Investigations on the San Antonio Terrace, Vandenberg Air Force Base, California*. Report on file at Central Coastal Information Center, University of California, Santa Barbara.
- 1990 *The Evolution of Chumash Society: A Comparative Study of Artifacts Used in Social System maintenance in the Santa Barbara Channel Region Before A.D. 1804*. Garland Publishing, New York.
- Krieger, Daniel E.
1988 *San Luis Obispo County*. Windsor Publications Inc., Northridge, California.
- Kroeber, Alfred
1925 *Handbook of the Indians of California*. Facsimile edition, California Book Company, 1953.
- Lindsey, Wesley C.
1983 *Soil Survey of San Luis Obispo County, California. Paso Robles Area*. United States Department of Agriculture.

Attachment 9

Mathes, W. M.

1968 *Sebastián Vizcaino and Spanish Expansion in the Pacific Ocean, 1580-1630*. California Historical Society, San Francisco.

Meighan, Clement

1979 *Glass Trade Beads in California*. Ms. on file at Lowie Museum of Anthropology. University of California, Berkeley.

Moratto, Michael

1984 *California Archaeology*. Academic Press, Inc. New York.

Morrison, Annie L and John H. Haydon

1917 *History of San Luis Obispo County and Environs, California*. Historic Record Company, Los Angeles.

Nicholson, Loren

1980 *Rails Across the Ranchos*. Valley Publishers. Fresno, California.

Ohles, Wallace V.

1997 *The Lands of Mission San Miguel*. Lord Dancer Press, Clovis California.

Olsen, W. H., and L. A. Payen

1969 *Archaeology of the Grayson Site*. California Department of Parks and Recreation Archaeological Report No. 12. Sacramento.

Rabb, L. Mark, and Daniel O. Larson

1997 *Medieval Climatic Anomaly and Punctuated Cultural Evolution in Coastal Southern California*. *American Antiquity* 62: 319-336.

Rogers, David B.

1929 *Prehistoric Man of the Santa Barbara Coast, California*. Santa Barbara Museum of Natural History Special Publication 1, Santa Barbara.

Rossi, Randall Steven

1979 *Land Use and Vegetation Change in the Oak Woodland-Savanna of Northern San Luis Obispo County, California (174-1978)*. PhD Dissertation, University of California, Berkeley.

Sawyer, Frank W.

1915 *Paso Robles Hot Springs California*. Sunset Publishing House, San Francisco.

Shumway, Burgess McK.

2007 *California Ranchos, Patented Private Land Grants Listed by County*. 2nd Edition, edited by Michael Burgess and Mary Wickizer Burgess. The Borgo Press.

Singer, Clay A.

2004 *Cultural Resources Survey and Impact Assessment for a 40 +/- Acre Property Located on Theater Drive in the City of Paso Robles, San Luis Obispo County, California*. C.A. Singer & Associates, Inc.

2006 *Cultural resources survey and impact assessment for a 5 acre property on Ramada Drive near the Town of Templeton in San Luis Obispo [APN 040-151-013]*. C.A. Singer & Associates, Inc.

Attachment 9

Stevens, Nathan, Richard T. Fitzgerald, Nancy Farrell, Mark A. Giambastiani, Jennifer M. Farquar, and Dayna Tinsley
2004 Archaeological Test Excavations at Santa Ysabel Ranch, Paso Robles, San Luis Obispo County, California. Report submitted to Weyrich Development Company, LLC. Cultural Resource Management Services, Paso Robles.

Squibb, Paul
1984 *Captain Portola in San Luis Obispo County in 1769*. Tabula Rasa Press. Morro Bay, California.

Wagner, H.R.
1924 The Voyage to California of Sebastian Rodriguez Cermeño in 1595. *California Historical Society Quarterly* 3 (1): 3-24.

EXHIBIT A

Records and Literature Search
Central Coast Information Center
Museum of Natural History
Santa Barbara, CA



Central Coast Information Center
 Santa Barbara Museum of Natural History
 2559 Puesta del Sol
 Santa Barbara, CA 93105
 PHONE (805) 682-4711 ext. 181
 FAX (805) 682-3170
 EMAIL ccic@sbnature2.org

Attachment 9

3/22/2022

Records Search # 22-066

Nancy Farrell
 Cultural Resource Management Services
 829 Paso Robles St.
 Paso Robles, CA 93446

Re: Coast Counties Peterbilt

The Central Coast Information Center received your record search request for the project area referenced above, located on the Templeton USGS 7.5' quad(s). The following reflects the results of the records search for the project area and a one quarter mile radius:

As indicated on the data request form, the locations of reports and resources are provided in the following format: custom GIS maps shapefiles hand-drawn maps none

Resources within project area:	0
Resources within ¼ mile radius:	0
Reports within project area:	2; SL-00022, SL-05188
Reports within ¼ mile radius:	5; SL-03641, SL-04555, SL-05757, SL-05808, SL-06130

- Resource Database Printout (list): enclosed not requested nothing listed
- Resource Database Printout (details): enclosed not requested nothing listed
- Resource Digital Database Records: enclosed not requested nothing listed
- Report Database Printout (list): enclosed not requested nothing listed.
- Report Database Printout (details): enclosed not requested nothing listed.
- Report Digital Database Records: enclosed not requested nothing listed.
- Resource Record Copies: enclosed not requested nothing listed.
- Report Copies: enclosed not requested nothing listed.
- OHP Historic Properties Directory: enclosed not requested nothing listed.
- Archaeological Determinations of Eligibility: enclosed not requested nothing listed.

The following sources of information are available at http://ohp.parks.ca.gov/?page_id=28065. Some of these resources used to be available through the CHRIS but because they are now online, they can be accessed directly. The Office of Historic Preservation makes no guarantees about the availability, completeness, or accuracy of the information provided through the sources listed below.

Attachment 9

<i>California State Lands Commission Shipwreck Database</i>	<i>Caltrans Historic Bridge Inventory</i>
<i>U.S. Geological Survey Historic Topographic Maps</i>	<i>Rancho Plat Maps</i>
<i>National Park Service National Register of Historic Places Nominations</i>	<i>Natural Resource Conservation Service Soil Survey Maps</i>
<i>US Bureau of Land Management General Land Office Records</i>	<i>California Historical Landmarks Listing (by county)</i>
<i>Five Views: An Ethnic Historic Site Survey for California (1988)</i>	<i>Historical Soil Survey Maps</i>

Please forward a copy of any resulting reports from this project to the office as soon as possible. Due to the sensitive nature of archaeological site location data, we ask that you do not include resource location maps and resource location descriptions in your report if the report is for public distribution. If you have any questions regarding the results presented herein, please contact the office at the phone number listed above.

The provision of California Historical Resources Information System (CHRIS) data via this records search response does not in any way constitute public disclosure of records otherwise exempt from disclosure under the California Public Records Act or any other law, including, but not limited to, records related to archeological site information maintained by or on behalf of, or in the possession of, the State of California, Department of Parks and Recreation, State Historic Preservation Officer, Office of Historic Preservation, or the State Historical Resources Commission.

Due to processing delays and other factors, not all of the historical resource reports and resource records that have been submitted to the Office of Historic Preservation are available via this records search. Additional information may be available through the federal, state, and local agencies that produced or paid for historical resource management work in the search area. Additionally, Native American tribes have historical resource information not in the CHRIS Inventory, and you should contact the California Native American Heritage Commission for information on local/regional tribal contacts.

Should you require any additional information for the above referenced project, reference the record search number listed above when making inquiries. Requests made after initial invoicing will result in the preparation of a separate invoice.

Thank you for using the CHRIS.

Sincerely,

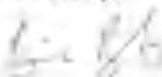

Brian Barbier
Coordinator

EXHIBIT B

Letter to NAHC
Response From NAHC
Letter To Native Americans and Groups
Response From Native Americans and Groups



Cultural Resource Management Services
829 Paso Robles Street
Paso Robles, CA 93446
Phone 805-237-3838

Attachment 9

March 16, 2022

Mr. Steven Quinn
Associate Governmental Program Analyst
California Native American Heritage Commission
1550 Harbor Blvd., Suite 100
West Sacramento, CA 95691

RE: Phase I Inventory Survey, Commercial Building
2805 Theatre Drive, Paso Robles, CA, APN: 009-851-022

Dear Mr. Quinn:

The owners of the property described above intends to construct a new commercial building on the identified parcel.

Cultural Resource Management Services (CRMS) has been retained, to prepare a Phase I surface survey as well as provide an early participation notice to interested Native Americans and Native American groups relative to the proposed construction project.

Please review the sacred lands files for any Native American Sacred resources or sites that may be within or adjacent to the area of potential effect (APE). Please verify that any sacred sites in the vicinity are not in the APE. The project area is within the corporate limits of the city of Paso Robles, San Luis Obispo county, and is identified on the attached portion of the USGS Templeton 7.5' Quadrangle. The study area falls within,, Township 27 South and Range 12 East MDM. The project location is depicted as a salmon colored polygon. As the area was part of a Rancho, there are no section lines.

Attachment 9

Page Two
March 16, 2022
Steven Quinn

Also provide a list, including names and addresses, of Native American individuals and organizations who may have knowledge of cultural resources in the project area; or who may have a concern or wish to comment on the project.

If you have any questions contact me at the phone number or address shown, or by email ronrose@crms.com. We look forward to your reply.

Best regards,

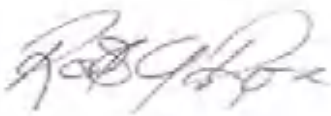
A handwritten signature in black ink, appearing to read "Ron Rose". The signature is stylized and somewhat cursive.

Ron Rose
Vice President

Encl: Portion of USGS 7.5' Quadrangle , Templeton, CA

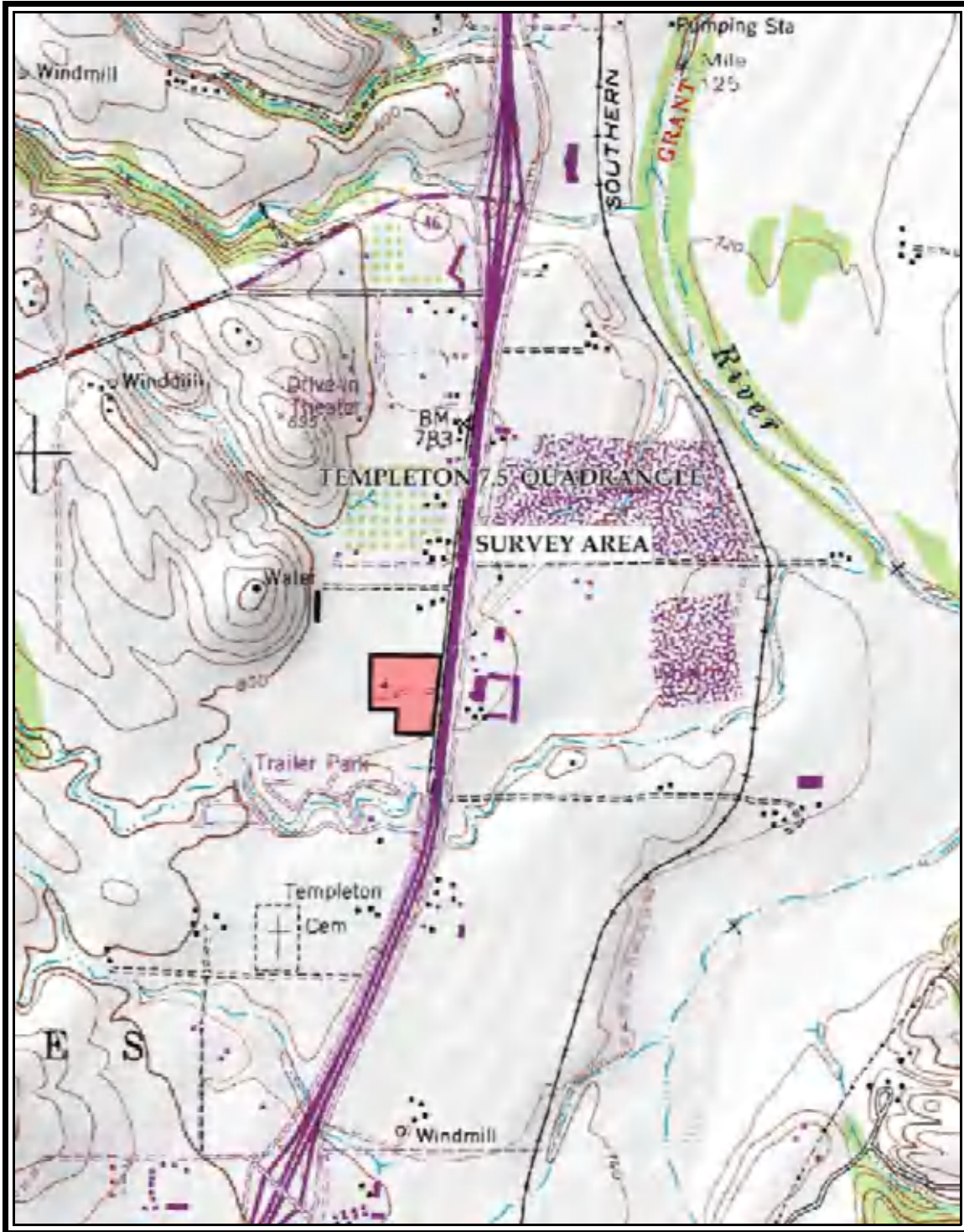

Portion of USGS 7.5' Quadrangle, Templeton, CA



NATIVE AMERICAN HERITAGE COMMISSION

April 24, 2022

Ron Rose
Cultural Resource Management Services

Via Email to: ronrose@crms.com

CHAIRPERSON
Laura Miranda
Luiseno

VICE CHAIRPERSON
Reginald Paganina
Ojibwa

PRESIDENTIAL
Russell Attebery
Paiute

SECRETARY
Sara Dutschke
Miwok

COMMISSIONER
William Mungary
Palaik/White Mountain
Palaik

COMMISSIONER
Isaac Bojorquez
Ojibwa/Castano

COMMISSIONER
Buffy McQuillen
Yokayo/Pomo, Full
Nambal

COMMISSIONER
Wayne Nelson
Luiseno

COMMISSIONER
Stanley Rodriguez
Kumeyaay

EXECUTIVE SECRETARY
Raymond C.
Hitchcock
Miwok/Istemon

NAHC HEADQUARTERS
1500 Harbor Boulevard
Suite 100
Wood Sacramento,
California 95691
PH: (916) 373-3710
nahc@nahc.ca.gov
NAHC.ca.gov

Re: Phase I Survey, Commercial Building 2805 Theatre Drive, Paso Robles, CA Project, San Luis Obispo County

Dear Mr. Rose:

A record search of the Native American Heritage Commission (NAHC) Sacred Lands File (SLF) was completed for the information you have submitted for the above referenced project. The results were negative. However, the absence of specific site information in the SLF does not indicate the absence of cultural resources in any project area. Other sources of cultural resources should also be contacted for information regarding known and recorded sites.

Attached is a list of Native American tribes who may also have knowledge of cultural resources in the project area. This list should provide a starting place in locating areas of potential adverse impact within the proposed project area. I suggest you contact all of those indicated; if they cannot supply information, they might recommend others with specific knowledge. By contacting all those listed, your organization will be better able to respond to claims of failure to consult with the appropriate tribes. If a response has not been received within two weeks of notification, the Commission requests that you follow-up with a telephone call or email to ensure that the project information has been received.

If you receive notification of change of addresses and phone numbers from tribes, please notify me. With your assistance, we can assure that our lists contain current information.

If you have any questions or need additional information, please contact me at my email address: Cody.Campagne@nahc.ca.gov.

Sincerely,

Cody Campagne
Cultural Resources Analyst

Attachment



Service

Cultural Resource Management

829 Paso Robles Street
Paso Robles, CA 93446
Phone 805-237-3838
Fax 805-237-3849

XXXXXXXXXXXXXXXXXXXXXXXXXXXXXXXXXXXX
XXXXXXXXXXXXXXXXXXXXXXXXXXXXXXXXXXXX
XXXXXXXXXXXXXXXXXXXXXXXXXXXXXXXXXXXX

April 25, 2022

RE: Phase I Archaeological Inventory Survey, APN: 009-851-022
2805 Theatre Drive, Paso Robles, CA

XXXXXXXXXXXX:

The owners of the property described above intend to construct a new commercial building on the property described above.

Cultural Resource Management Services (CRMS) has been retained, to prepare a Phase I surface survey as well as provide an early participation notice to interested Native Americans and Native American groups relative to the proposed construction project.

The project area is within the corporate limits of the city of Paso Robles, San Luis Obispo county, and is identified on the attached portion of the USGS Templeton 7.5' Quadrangle. The study area falls within,, Township 27 South and Range 12 East MDM. The project location is depicted as a salmon colored polygon. As the area was part of a Rancho, there are no section lines.

The Native American Heritage Commission has indicated that no Sacred Sites exist either on the property or in the near vicinity. If you have knowledge of the area, please share that information with me in your comments. If you have any questions contact me at the phone number or address shown, or by email ronrose@crms.com. We look forward to your reply.

Best regards,

Ron Rose
Vice President

Encl: Portion of USGS 7.5' Quadrangle, Templeton, CA

The letter on the previous page was sent to the following individuals and groups. XXXX substituted for address and salutation.

**Native American Heritage Commission
Native American Contact List
San Luis Obispo County
4/24/2022**

<p>Barbareno/ Venturoeno Band of Mission Indians Brenda Guzman, 58 N. Ann Street, #8 Ventura, CA, 93001 Phone: (209) 601 - 4676 brendamguzman@gmail.com</p>	Chumash	<p>Salinan Tribe of Monterey, San Luis Obispo Counties Patti Dunton, Tribal Administrator 7070 Morro Road, Suite A Atascadero, CA, 93422 Phone: (805) 464 - 2650 info@salinantribe.com</p>	Salinan
<p>Barbareno/ Venturoeno Band of Mission Indians Annette Ayala, 188 S. Santa Rosa Street Ventura, CA, 93001 Phone: (805) 515 - 9844 annetteayala78@yahoo.com</p>	Chumash	<p>San Luis Obispo County Chumash Council 1030 Ritchie Road Grover Beach, CA, 93433</p>	Chumash
<p>Barbareno/ Venturoeno Band of Mission Indians Patrick Tumamait, 992 El Camino Corto Ojai, CA, 93023 Phone: (805) 216 - 1253</p>	Chumash	<p>Santa Ynez Band of Chumash Indians Kenneth Kahn, Chairperson P.O. Box 517 Santa Ynez, CA, 93450 Phone: (805) 688 - 7997 Fax: (805) 686-9578 kkahn@santaynezchumash.org</p>	Chumash
<p>Barbareno/Venturoeno Band of Mission Indians Julie Tumamait-Stenslie, Chairperson 365 North Poli Ave Ojai, CA, 93023 Phone: (805) 546 - 6214 jtumamait@hotmail.com</p>	Chumash	<p>Tule River Indian Tribe Joey Garfield, Tribal Archaeologist P. O. Box 589 Porterville, CA, 93258 Phone: (559) 783 - 8892 Fax: (559) 783-8932 joey.garfield@tulerivertribe-nsn.gov</p>	Yokut
<p>Chumash Council of Bakerfield Julio Quair, Chairperson 729 Texas Street Bakerfield, CA, 93307 Phone: (661) 322 - 0121 chumashtribe@sbcglobal.net</p>	Chumash	<p>Tule River Indian Tribe Kerri Vera, Environmental Department P. O. Box 589 Porterville, CA, 93258 Phone: (559) 783 - 8892 Fax: (559) 783-8932 kerri.vera@tulerivertribe-nsn.gov</p>	Yokut
<p>Northern Chumash Tribal Council Violet Walker, Chairperson P.O. Box 8533 Los Osos, CA, 93412 Phone: (760) 549 - 3532 violetsagewalker@gmail.com</p>	Chumash	<p>Tule River Indian Tribe Neil Peyron, Chairperson P.O. Box 589 Porterville, CA, 93258 Phone: (559) 781 - 4271 Fax: (559) 781-4610 neil.peyron@tulerivertribe-nsn.gov</p>	Yokut

This list is current only as of the date of this document. Distribution of this list does not relieve any person of statutory responsibility as defined in Section 7050.5 of the Health and Safety Code, Section 5097.54 of the Public Resources Section 5097.58 of the Public Resources Code.

This list is only applicable for contacting local Native Americans with regard to cultural resources assessment for the proposed Phase I Survey, Commercial Building 2806, Thrasher Drive, Pismo Beach, CA Project, San Luis Obispo County.

Native American Heritage Commission
Native American Contact List
San Luis Obispo County
4/24/2022

Xolon-Salinan Tribe

Donna Haro, Tribal Headwoman
P. O. Box 7045 Salinan
Spreckels, CA, 93962
Phone: (925) 470 - 5019
dhxolonaakletse@gmail.com

Xolon-Salinan Tribe

Karen White, Chairperson
P. O. Box 7045 Salinan
Spreckels, CA, 93962
Phone: (831) 238 - 1488
xolon.salinan.heritage@gmail.com

***yak tityu tityu yak tihini –
Northern Chumash Tribe***

Mona Tucker, Chairperson
660 Camino Del Rey Chumash
Arroyo Grande, CA, 93420
Phone: (805) 748 - 2121
olivas.mona@gmail.com

This list is current only as of the date of this document. Distribution of this list does not relieve any person of statutory responsibility as defined in Section 7059.5 of the Health and Safety Code, Section 5097.94 of the Public Resource Section 5097.96 of the Public Resources Code.

This list is only applicable for contacting local Native Americans with regard to cultural resources assessment for the proposed Phase I Survey, Commercial Building 2805 Theatre Drive, Paso Robles, CA Project, San Luis Obispo County.

Attachment 9

RESPONSE TO LETTER WRITTEN

April 2, 2022 response from Julie Tumamait-Stenslie

Ron

I will defer any comments to Mona Tucker

Thanks

Julie

Attachment 9

Environmental Noise Assessment

Peterbilt Service and Sales Center

Paso Robles, California

BAC Job # 2022-088

Prepared For:

City of Paso Robles

Attn: Katie Banister
1000 Spring Street
Paso Robles, CA 93446

Prepared By:

Bollard Acoustical Consultants, Inc.



Dario Gotchet, Principal Consultant

September 15, 2022



Introduction

The proposed Peterbilt Service and Sales Center (project) is located at 2805 Theatre Drive in Paso Robles, California (APN: 009-851-022). The project proposes the development of a service center for semi-trucks, a retail parts department, and a dealership. The site amenities would include offices for employees, a lounge area for customers, an outdoor display area, and customer parking. The project area with aerial imagery is shown in Figure 1. The project site plan is presented in Figure 2.

Due to the proximity of the proposed project to existing residential uses, Bollard Acoustical Consultants, Inc. (BAC) was retained by the City of Paso Robles to prepare an assessment of potential noise impacts associated with the project. Specifically, the purposes of this assessment are to quantify noise levels associated with proposed on-site operations, to assess state of compliance of those noise levels with applicable City of Paso Robles noise standards, and if necessary, to recommend measures to reduce noise levels to acceptable limits at the nearest existing residential uses.

Noise Fundamentals and Terminology

Noise is often described as unwanted sound. Sound is defined as any pressure variation in air that the human ear can detect. If the pressure variations occur frequently enough (at least 20 times per second), they can be heard, and thus are called sound. Measuring sound directly in terms of pressure would require a very large and awkward range of numbers. To avoid this, the decibel scale was devised. The decibel scale allows a million-fold increase in pressure to be expressed as 120 dB. Another useful aspect of the decibel scale is that changes in levels (dB) correspond closely to human perception of relative loudness. Appendix A contains definitions of Acoustical Terminology. Figure 3 shows common noise levels associated with various sources.

The perceived loudness of sounds is dependent upon many factors, including sound pressure level and frequency content. However, within the usual range of environmental noise levels, perception of loudness is relatively predictable, and can be approximated by weighing the frequency response of a sound level meter by means of the standardized A-weighting network. There is a strong correlation between A-weighted sound levels (expressed as dBA) and community response to noise. All noise levels reported in this section are in terms of A-weighted levels in decibels.

Community noise is commonly described in terms of the “ambient” noise level, which is defined as the all-encompassing noise level associated with a given noise environment. A common statistical tool to measure the ambient noise level is the average, or equivalent, sound level (L_{eq}) over a given time period (usually one hour). The L_{eq} is the foundation of the Day-Night Average Level noise descriptor (DNL or L_{dn}), and shows very good correlation with community response to noise.



- Legend**
- - - Project Border (Approximate)
 - Residential Parcel Boundaries
 - ▲ Long-Term Ambient Noise Survey Location

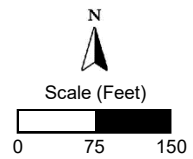

Peterbilt Service & Sales Center
Paso Robles, California

Project Area

Figure 1



Attachment 9

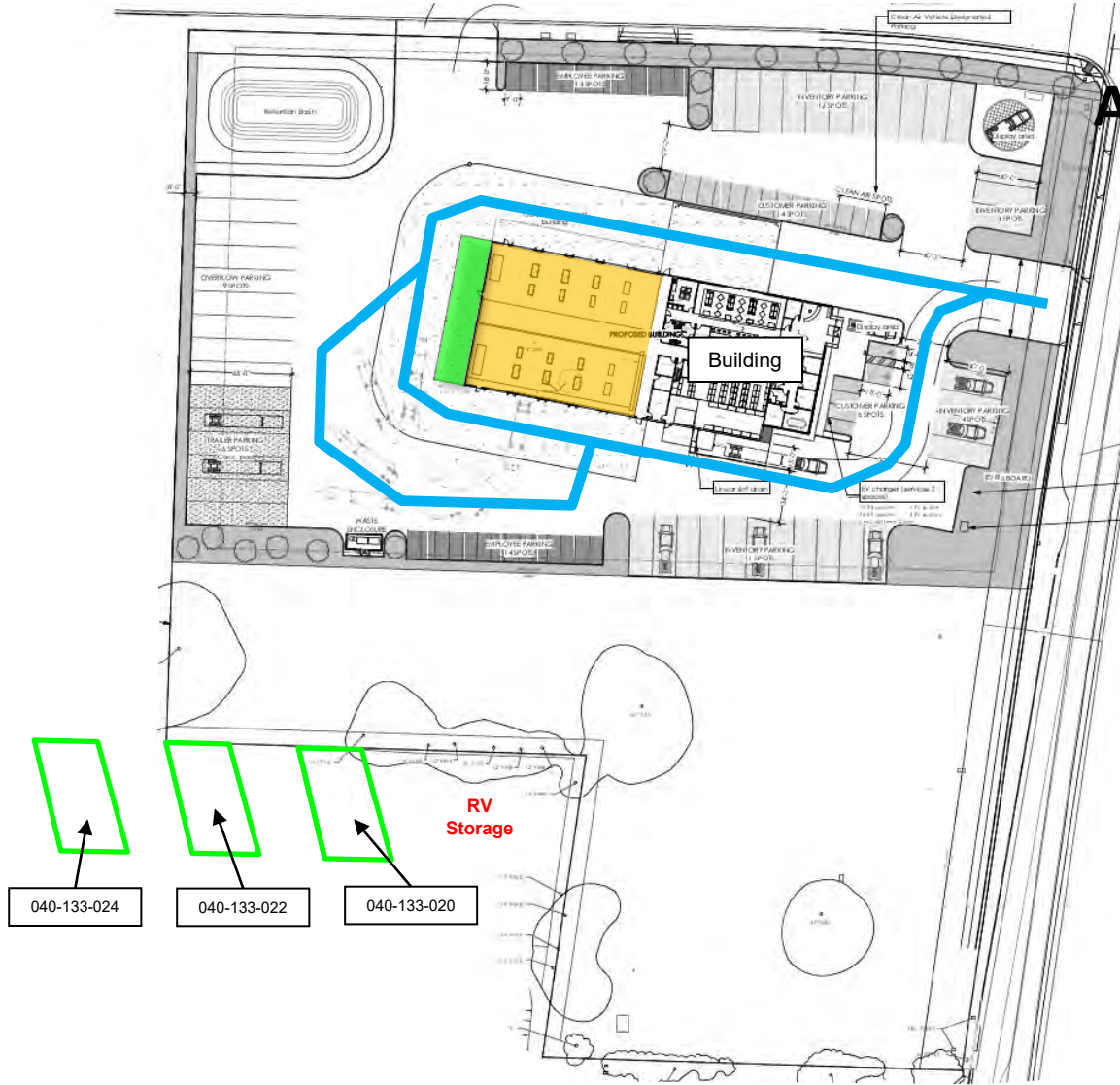

Legend

- Primary On-Site Truck Circulation
- Service Department (Within Building)
- CNG Vehicle Repair Station (Covered Outdoor Bay)

Peterbilt Service & Sales Center
Paso Robles, California

Project Site Plan

Figure 2



Figure 3
Common Noise Levels Associated with Various Sources
Decibel Scale (dBA)*

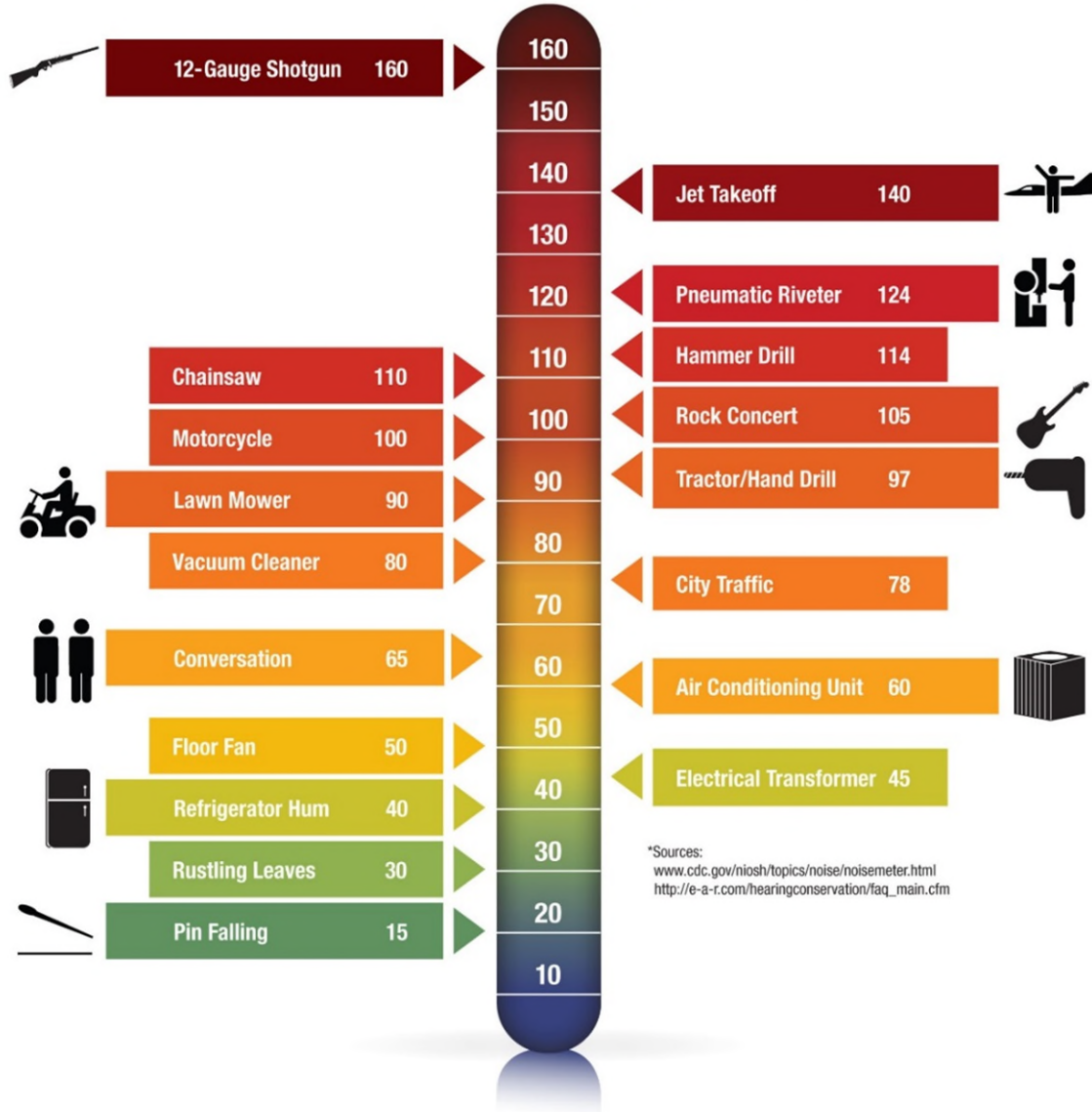

The Day-Night Average Level (DNL or L_{dn}) is based upon the average noise level over a 24-hour day, with a +10-decibel weighting applied to noise occurring during nighttime (10:00 p.m. to 7:00 a.m.) hours. The nighttime penalty is based upon the assumption that people react to nighttime noise exposures as though they were twice as loud as daytime exposures. Because DNL represents a 24-hour average, it tends to disguise short-term variations in the noise environment. DNL-based noise standards are commonly used to assess noise impacts associated with traffic, railroad, and aircraft noise sources.

Existing Ambient Noise Environment in the Project Vicinity

The existing ambient noise environment in the immediate project vicinity is defined primarily by traffic on U.S. Highway 101 and Theatre Avenue, and to a lesser extent by nearby commercial operations. To generally quantify the existing ambient noise environment in the immediate project vicinity, BAC conducted long-term (24-hour) noise level measurements on the project site from Monday, June 6, 2022, to Tuesday, June 7, 2022. The noise survey location, identified on Figure 1, was selected to be generally representative of the ambient noise level environment at the nearest residential uses located immediately south of the project site. Photographs of the noise level survey location are provided in Appendix B.

A Larson-Davis Laboratories (LDL) Model LxT precision integrating sound level meter was used to complete the ambient noise level survey. The meter was calibrated immediately before and after use with an LDL Model CAL200 acoustical calibrator to ensure the accuracy off the measurements. The equipment used meets all pertinent specifications of the American National Standards Institute for Type 1 sound level meters (ANSI S1.4). The results of the long-term ambient noise survey are shown numerically and graphically in Appendices C and D (respectively) and are summarized in Table 1.

Table 1
Summary of Long-Term Ambient Noise Measurement Results¹

Site Description ²	Date	DNL (dB)	Average Measured Hourly Noise Levels (dB)					
			Daytime ³		Evening ⁴		Nighttime ⁵	
			L _{eq}	L _{max}	L _{eq}	L _{max}	L _{eq}	L _{max}
South end of project parcel near residential uses	6/6/22 – 6/7/22	59	54	64	53	64	52	62

¹ Detailed summaries of the noise monitoring results are provided in Appendices C and D.
² Long-term ambient noise monitoring location is identified on Figure 1.
³ Daytime: 7:00 a.m. to 7:00 p.m.
⁴ Evening: 7:00 p.m. to 10:00 p.m.
⁵ Nighttime: 10:00 p.m. to 7:00 a.m.

Source: *Bollard Acoustical Consultants, Inc. 2022.*

Criteria for Acceptable Noise Exposure

City of Paso Robles Municipal Code

Section 21.60.060 of the City of Paso Robles Municipal Code establishes exterior and interior noise standards that would be applicable to project on-site operations. That code section has been reproduced below.

21.60.060 – Exterior and interior noise standards:

- A. The noise standards contained in Table 2 (below), unless otherwise specifically indicated in this chapter, shall apply to all noise-sensitive exterior and interior areas within Paso Robles.

- B. It is unlawful for any person at any location within the city to create any noise which causes the noise levels on an affected property, when measured in the designated sensitive exterior or interior location, to exceed the noise standards specified below in Table 2.

**Table 2
Exterior Noise Standards for Locally Regulated (Non-Transportation) Noise Sources**

Receiving Land Use	Period ³	Exterior Areas ¹		Interior Spaces ²	
		L _{eq} ⁴	L _{max} ⁵	L _{eq} ⁴	L _{max} ⁵
Residential	Day	55	75	45	60
	Evening	50	70	40	55
	Night	45	65	35	45
Mixed Use Residential	Day	---	---	45	60
	Evening	---	---	40	55
	Night	---	---	35	45
Transient Lodging Hospitals ⁶ & Nursing Homes	Day	60	75	45	60
	Evening	55	75	40	55
	Night	50	70	35	45
Uptown Town Center S.P. Area (UTCSP) Residential	Day	60	80	45	60
	Evening	55	75	40	55
	Night	50	70	35	45
Theaters & Auditoriums	Day	55	75	35	40
	Evening	50	70	35	40
	Night	---	---	35	40
Churches, Meeting Halls, Libraries	Day	55	75	45	55
	Evening	50	70	40	55
Schools ⁷	Day	---	---	40	55
	Evening	---	---	40	55
Office/Professional	Day	60	80	45	60
	Evening	55	75	45	60
Commercial/Retail Buildings	Day	60	80	50	60
	Evening	55	75	50	60
Playgrounds, Parks, etc.	Day	55	75	---	---
	Evening	55	75	---	---
Industrial	Day	60	80	50	60
	Evening	55	75	50	60

Specific Notes:

1. Noise sensitive areas are defined acoustic terminology section.
2. Interior noise level standards are applied within noise-sensitive areas of the various land uses, as defined in the acoustic terminology section, with windows and doors closed.
3. Daytime hours = 7 am – 7 pm, Evening hours = 7 pm – 10 pm, Nighttime hours = 10 pm – 7 am.
4. L_{eq} = Average or “Equivalent” noise level during the worst-case hour in which the building is in use.
5. L_{max} = Highest measured sound level occurring during a given interval of time (Typically 1 hour).
6. Hospitals are often noise-generating uses. The exterior noise level standards for hospitals are applicable only at clearly identified areas designated for outdoor relaxation by either hospital staff or patients.
7. Exterior areas of school uses are not typically noise-sensitive. As a result, the standards for schools are focused on the interior office and classroom spaces.

General Notes Applicable to All Noise Standards and Land Uses:

- a. Where the noise source in question consists of speech or music, or is impulsive in nature, or contains a pure tone, the noise standards of this table are reduced by 5 dB.
- b. Where ambient noise levels exceed the noise level standards shown above, the noise standards shall be increased in 5 dB increments to encompass the ambient.
- c. Reductions in the noise standards for noise sources identified in general note “A” above shall be applied after any increases warranted by elevated ambient conditions prescribed in general note “B”, subject to verification through a noise study.

Source: City of Paso Robles Municipal Code, Section 21.60.060.

Noise Level Criteria Applied to the Project

The nearest noise-sensitive receptors to the project site have been identified as residences to the south within the Los Robles Mobile Home Estates. These residential uses are shown on Figure 1. Based on the proposed uses of the project (i.e., commercial services and sales), it is reasonably assumed that hours of operation for the business would be limited to daytime and evening hours only. Based on the information above, the City’s exterior and interior daytime and evening noise level limits for residential uses shown in Table 2 would be applicable to the project. However, pursuant to the footnote “b” contained in Table 2, where ambient noise levels exceed the exterior noise level standards shown in Table 2, the exterior noise standards shall be increased in 5 dB increments to encompass the ambient.

Based on the results from the BAC ambient noise level survey at the nearest residential uses to the south (Table 1), and pursuant to the adjustment criteria contained in Table 2, the following exterior noise level limits shown in Table 3 were applied to project on-site operations and assessed at the nearest residential uses to the south of the project. Satisfaction of the City’s noise level standards at the closest residential uses would ensure compliance with the City’s noise level limits at residential uses located farther away.

**Table 3
Municipal Code Exterior Noise Level Standards Applied to the Project**

Average Measured Hourly Noise Levels (dB) ¹				Unadjusted Noise Standards (dB) ²				Ambient Exceed Standards? ³				City Standards Applied to Project (dB) ⁴			
Daytime		Evening		Daytime		Evening		Daytime		Evening		Daytime		Evening	
L _{eq}	L _{max}	L _{eq}	L _{max}	L _{eq}	L _{max}	L _{eq}	L _{max}	L _{eq}	L _{max}	L _{eq}	L _{max}	L _{eq}	L _{max}	L _{eq}	L _{max}
54	64	53	64	55	75	50	70	No	No	Yes	No	55	75	55	70

¹ Average measured hourly noise levels at the nearest residential uses to south (Table 1).
² Unadjusted City of Paso Robles Municipal Code exterior noise level limits for residential uses (Table 2).
³ Determination based on a comparison of measured ambient noise level data and the City’s noise standards.
⁴ Adjusted noise standards in red pursuant to footnote b of Table 2.

Source: City of Paso Robles Municipal Code Section 21.60.060 and BAC.

The exterior noise level limits shown in Table 3 were applied at the outdoor areas (i.e., backyards) of the nearest residential uses to the south. Additionally, the City’s (unadjusted) interior noise level limits for residential uses presented in Table 2 were also applied to the project.

Evaluation of Project-Generated Operations Noise

As mentioned previously, the project proposes the development of a service center for semi-trucks, a retail parts department, and a dealership. The site amenities would include offices for employees, a lounge area for customers, an outdoor display area, and customer parking.

The most significant noise sources associated with normal project operations will likely consist of air compressors and pneumatic tools associated with the service department (within the building), and on-site truck circulation. In addition, activities occurring within a covered outdoor

maintenance area for compressed natural gas (CNG) vehicles have also been identified as a primary noise source. The locations of the on-site truck circulation route, service department and CNG maintenance area are shown on Figure 2. Analyses of noise exposure associated with the above-identified on-site activities at the nearest residential uses to the south are presented in the following section.

On-Site Truck Circulation Noise

It is expected that most of the on-site truck circulation will be associated with the service department. The project site plan indicates that the trucks will enter and exit the property via one access point on Theatre Drive. Once on the project property, the trucks will head west towards the service department near the rear of the building. The location of the on-site circulation route, which include truck turnaround areas indicated in the site plan, is illustrated on Figure 2.

Heavy truck arrivals and departures, and on-site truck circulation, will occur at low speeds. To quantify the noise generation of slow moving trucks, BAC utilized single-event passby noise test results for slow-moving heavy trucks conducted at the West El Camino truck stop in Sacramento, California. The passby measurements were conducted at a reference distance of 50 feet at a location suitable for isolation of individual passby events. According to BAC file data, single-event heavy truck passby noise levels are approximately 74 dB L_{max} and 83 dB SEL at a reference distance of 50 feet.

Because the City of Paso Robles Municipal Code noise standards are provided in terms of both hourly average (L_{eq}) noise levels and individual maximum (L_{max}) noise levels, it is necessary to identify the number of truck movements occurring during a typical busy hour of operations to assess compliance with the L_{eq} -based standards. Based on the project site plan, the truck service department has approximately 10 bays (8 work bench areas, 2 having double bay capacity). Conservatively assuming that all 10 truck bays could both fill and empty during a worst-case busy hour, the project would generate 20 truck passbys during that hour. Based on a conservative estimate of 20 truck passbys during a given worst-case hour and an SEL of 83 per passby, the hourly average noise level generated by heavy truck passbys computes to 60 dB L_{eq} at a reference distance of 50 feet during a worst-case busy hour of service operations.

Based on the assumptions and equation provided above, and assuming standard sound wave spreading loss (-6 dB per doubling of distance), worst-case on-site truck circulation noise exposure at the nearest residential uses to the south was calculated and the results of those calculations are presented in Table 4.

Table 4
Predicted Worst-Case On-Site Truck Circulation Noise Levels at Nearest Residential Uses

Residential APN ¹	Distance (ft) ²	Predicted Noise Levels (dB)	
		L _{eq}	L _{max}
040-133-020	200	51	62
040-133-022	215	51	61
040-133-024	280	49	59
Applied Daytime Noise Standards (dB)³		55	75
Applied Evening Noise Standards (dB)³		55	70
¹ Residential parcels are shown on Figures 1 and 2. ² Distances scaled from nearest on-site truck circulation to backyard of residences using the provided site plan. ³ Applied noise standards based on BAC noise survey and City adjustment criteria.			

Source: *Bollard Acoustical Consultants, Inc. 2022.*

As indicated in Table 4, worst-case project on-site truck circulation noise level exposure is predicted to satisfy the applied City of Paso Robles Municipal Code exterior daytime and evening noise level limits at the nearest residential uses. In addition, standard residential construction (e.g., stucco siding, STC-27 windows, door weather-stripping, exterior wall insulation, composition plywood roof), typically results in an exterior to interior noise reduction of approximately 25 dB with windows and doors closed. Given this exterior-to-interior noise reduction typically achieved from standard residential construction, and based on the predicted exterior noise levels in Table 4, project on-site truck circulation noise level exposure is expected to be well below the Municipal Code interior daytime and evening noise level standards within the interior areas of the nearest residences.

Based on the analysis provided above, project on-site truck circulation noise level exposure is expected to satisfy the applied City of Paso Robles Municipal Code exterior and interior noise level criteria *provided* the following specific measure is implemented by the project:

1. All on-site truck circulation should be limited to daytime and/or evening hours only (i.e., no operations during nighttime hours).

Service Department Equipment Noise

The project site plans indicate the truck service/repair department will be located within the west end of the proposed building. The site plans further indicate that the service portion of the building will have a total of 10 bay doors, distributed evenly between the north and south sides of the building. The proposed building and service department are shown in Figure 2.

To quantify noise levels associated with service department equipment, BAC utilized file data collected for an automobile repair facility (Red Rocket Automotive Repair Facility in Sacramento, California – 2013). Specific noise sources quantified in the noise level data included an air compressor, air hammer, impact wrench, hydraulic lift, and an oil pump. The results of the reference noise level measurements are contained below in Table 5.

Table 5
Reference Noise Levels Collected at the Red Rocket Repair Facility in Sacramento, CA (2013)

Equipment	Measurement Distance (ft)	L _{eq} While in Use (dB)	Minutes Per Hour Used (est.) ¹	Computed Hourly L _{eq} (dB)	Measured L _{max} (dB)
Compressor	30	73	15	67	75
Air hammer	30	92	5	81	95
Impact wrench	30	75	10	67	82
Hydraulic lift	30	81	10	73	84
Oil pump	15	70	10	62	71

¹ The number of minutes in any given hour each noise source would be in operation was estimated from previous BAC observations at automobile repair facilities, as noise-producing equipment is not in constant use.

Source: Bollard Acoustical Consultants, Inc. 2013.

Based on the reference noise measurements for the equipment in Table 5, and assuming standard sound wave spreading loss (-6 dB per doubling of distance), equipment noise exposure at the nearest residential uses to the south was calculated and the results of those calculations are presented below in Tables 6 and 7. The data shown in Table 6 reflect predicted equipment noise levels at the nearest residential uses to the south with service department bay doors on the south and west sides of the building in the open position. Predicted equipment noise levels presented in Table 7 include consideration of the sound transmission loss that would be provided by the bay doors on the south and west sides of the building in the closed position during operations and have been adjusted by -15 dB.

According to the provided site plans, the air compressor for the service department is proposed to be located above the covered outdoor CNG vehicle maintenance area on the west side of the building (i.e., equipment will not be located within the building). As a result, no adjustment for service department bay door or building facade transmission loss was applied to air compressor noise level exposure at the nearest residential uses in Table 7.

**Table 6
Predicted Service Department Equipment Noise Levels at Nearest Residential Uses – Bay Doors Open**

Residential APN ¹	Distance (ft) ²	Predicted Equipment Noise Levels (dB)											
		Compressor ³		Air Hammer		Impact Wrench		Hydraulic Lift		Oil Pump		Combined ³	
		Leq	Lmax	Leq	Lmax	Leq	Lmax	Leq	Lmax	Leq	Lmax	Leq	Lmax
040-133-020	280	48	56	62	76	48	63	54	65	37	46	63	76
040-133-022	330	46	54	60	74	46	61	52	63	35	44	61	74
040-133-024	415	44	52	58	72	44	59	50	61	33	42	59	72
Applied Daytime Noise Standards (dB)⁴											55	75	
Applied Evening Noise Standards (dB)⁴											55	70	
¹ Residential parcels are shown on Figures 1 and 2. ² Distances scaled from the nearest work area within service department to backyard of residences using the provided site plan. ³ Calculated combined Leq and highest predicted Lmax noise levels from all equipment. ⁴ Applied noise standards based on BAC noise survey and City adjustment criteria.													

Source: Bollard Acoustical Consultants, Inc. 2022.

**Table 7
Predicted Service Department Equipment Noise Levels at Nearest Residential Uses – Bay Doors Closed**

Residential APN ¹	Distance (ft) ²	Predicted Equipment Noise Levels (dB) ³											
		Compressor		Air Hammer		Impact Wrench		Hydraulic Lift		Oil Pump		Combined ⁴	
		Leq	Lmax	Leq	Lmax	Leq	Lmax	Leq	Lmax	Leq	Lmax	Leq	Lmax
040-133-020	280	48	56	47	61	33	48	39	50	22	31	51	61
040-133-022	330	46	54	45	59	31	46	37	48	20	29	49	59
040-133-024	415	44	52	43	57	29	44	35	46	<20	27	47	57
Applied Daytime Noise Standards (dB)⁵											55	75	
Applied Evening Noise Standards (dB)⁵											55	70	
¹ Residential parcels are shown on Figures 1 and 2. ² Distances scaled from the nearest work area within service department to backyard of residences using the provided site plan. ³ Predicted equipment noise levels with consideration of bay doors on south and west sides of service department in the closed position during equipment operations. No sound transmission loss adjustment for bay doors/building facade applied to predicted air compressor noise levels. ⁴ Calculated combined Leq and highest predicted Lmax noise levels from all equipment. ⁵ Applied noise standards based on BAC noise survey and City adjustment criteria.													

Source: Bollard Acoustical Consultants, Inc. 2022.

As indicated in Table 6, noise levels associated with air hammer equipment operations with bay doors in the *open* position could exceed the applied City of Paso Robles Municipal Code exterior daytime and evening noise level limits at the nearest residential uses. Noise from all other sources is predicted to be satisfactory with the City standards. With service department bay doors in the *closed* position, all equipment noise levels are predicted to satisfy the applied Municipal Code exterior daytime and evening noise level limits at the nearest residential uses to the south. Additionally, given the exterior to interior noise reduction typically achieved from standard residential construction (approximately 25 dB with windows and doors closed), service department equipment noise level exposure is expected to satisfy the Municipal Code interior daytime and evening noise level standards within the interior areas of the nearest residences – both with building bay doors in the open and closed positions.

Based on the analysis provided above, project service department equipment noise level exposure is expected to satisfy the applied City of Paso Robles Municipal Code exterior and interior noise level criteria *provided* the following specific measures are implemented by the project:

1. All service department operations should be limited to daytime and/or evening hours only (i.e., no operations during nighttime hours).
2. Operations within the service department area of the building should occur with south and west side bay doors in the closed position while air hammer usage is occurring. Additionally, service technicians and management should be aware of equipment use during the brief periods in which air hammer usage is occurring to reduce to the potential for an exceedance of the applied Municipal Code noise level criteria at the closest residential uses.

CNG Vehicle Maintenance Area Equipment Noise

An analysis of service department equipment noise level exposure was presented in the previous section. Based on the reference noise measurements in Table 5, and assuming standard sound wave spreading loss (-6 dB per doubling of distance), CNG vehicle maintenance area equipment noise exposure at the nearest residential uses to the south was calculated and the results of those calculations are presented in Table 8. It should be noted that not all of the equipment identified in Table 5 was utilized in the analysis of CNG vehicle maintenance area noise exposure. Rather, this analysis focuses on assumed equipment usage within the outdoor CNG vehicle maintenance area.

**Table 8
Predicted CNG Vehicle Maintenance Area Equipment Noise Levels at Nearest Residential Uses**

Residential APN ¹	Distance (ft) ²	Predicted Equipment Noise Levels (dB)							
		Compressor		Impact Wrench		Oil Pump		Combined ³	
		Leq	Lmax	Leq	Lmax	Leq	Lmax	Leq	Lmax
040-133-020	260	48	56	48	63	37	46	51	63
040-133-022	300	47	55	47	62	36	45	50	62
040-133-024	385	45	53	45	60	34	43	48	60
Applied Daytime Noise Standards (dB)⁴								55	75
Applied Evening Noise Standards (dB)⁴								55	70
¹ Residential parcels are shown on Figures 1 and 2. ² Distances scaled from CNG vehicle maintenance area to backyard of residences using the provided site plan. ³ Calculated combined Leq and highest predicted Lmax noise levels from all equipment. ⁴ Applied noise standards based on BAC noise survey and City adjustment criteria.									

Source: *Bollard Acoustical Consultants, Inc. 2022.*

The Table 8 data indicate noise levels associated with outdoor CNG vehicle maintenance area equipment are predicted to satisfy the applied City of Paso Robles Municipal Code exterior daytime and evening noise level limits at the nearest residential uses. In addition, given the exterior to interior noise reduction typically achieved from standard residential construction (approximately 25 dB with windows and doors closed), CNG vehicle maintenance equipment noise level exposure is expected to satisfy the Municipal Code interior daytime and evening noise level standards within the interior areas of the nearest residences.

Based on the analysis provided above, project CNG vehicle repair equipment noise level exposure is expected to satisfy the applied City of Paso Robles Municipal Code exterior and interior noise level criteria *provided* the following specific measures are implemented by the project:

1. All operations within the outdoor CNG vehicle maintenance area should be limited to daytime and/or evening hours only (i.e., no operations during nighttime hours).
2. To reduce the potential for an exceedance of the applied City of Paso Robles Municipal Code noise criteria at the nearest residential uses, air hammers or hydraulic lifts should not be used or installed in the outdoor CNG vehicle maintenance area.

Public Address System

It is unclear at the time of writing this report whether the project will include a public address (PA) system. However, the loudness of a PA system is highly dependent on variables that include system power output, speaker distance and directionality relative to receiver, and volume level. Thus, it is difficult to quantify project PA system noise exposure with reasonable levels of precision.

Based on the experience of BAC with PA systems, the loudness of the system is typically set above ambient conditions to be clearly heard by its recipients. However, because the Municipal

Code noise level criteria applicable to this project are based on measured ambient conditions, such a configuration would likely exceed acceptable Municipal Code noise level limits.

For BAC to quantify noise associated with a PA system with a high level of precision (should one be proposed), a specific analysis prepared by a sound system designer would be required. Specifically, specifications for the system including overall noise level exposure at certain distances with consideration of speaker directionality would be needed. In absence of such specifications from a sound designer, it is the recommendation of BAC that the professional installer of the PA system (should one be proposed), ensure through analysis and testing that the equipment does not exceed 65 dB L_{max} at the nearest residential property lines. An overall PA system noise level of 65 dB L_{max} at the nearest residential property lines would avoid the potential for an exceedance of the Municipal Code's daytime and evening maximum noise level standards at those locations.

Conclusions and Recommendations

This analysis concludes that noise generated by on-site truck circulation is expected to satisfy the applied City of Paso Robles daytime and evening exterior and interior noise level limits at the nearest residential uses to the south of the project. This analysis further concludes that equipment noise levels from service department and CNG vehicle maintenance activities are expected to satisfy the applied City of Paso Robles daytime and evening exterior and interior noise level limits at the nearest residential uses to the south of the project *provided* that the following specific measures are implemented by the project:

1. On-site truck circulation, service department operations, and outdoor CNG vehicle maintenance area activities should be limited to daytime and/or evening hours only (i.e., no operations during nighttime hours).
2. Operations within the service department area of the building should occur with south and west side bay doors in the closed position at all times while air hammer usage is occurring. Additionally, service technicians and management should be aware of equipment use during the brief periods in which air hammer usage is occurring to reduce to the potential for an exceedance of the applied Municipal Code noise level criteria at the closest residential uses.
3. To reduce the potential for an exceedance of the applied Municipal Code noise level criteria at the nearest residential uses, air hammers or hydraulic lifts should not be used or installed in the outdoor CNG vehicle maintenance area.

Finally, it is unclear at the time of writing this report whether the project will include a public address (PA) system. Should one be proposed, it is the recommendation of BAC that the professional installer of the PA system ensure through analysis and testing that the equipment does not exceed 65 dB L_{max} at the nearest residential property lines. An overall PA system noise level of 65 dB L_{max} at the nearest residential property lines would avoid the potential for an exceedance of the Municipal Code's daytime and evening maximum noise level standards at those locations.

Attachment 9

Bollard Acoustical Consultants, Inc. (BAC)

These conclusions are based on the data and assumptions cited herein and on the site plan shown in Figure 2. Any substantive revisions to the project site plan or proposed operations could cause actual noise levels to vary relative to those predicted herein. BAC is not responsible for such revisions.

This concludes BAC's environmental noise assessment for the proposed Peterbilt Service and Sales Center in Paso Robles, California. Please contact BAC at (530) 537-2328 or info@bacnoise.com with any questions regarding this assessment.

Appendix A Acoustical Terminology

Acoustics	The science of sound.
Ambient Noise	The distinctive acoustical characteristics of a given space consisting of all noise sources audible at that location. In many cases, the term ambient is used to describe an existing or pre-project condition such as the setting in an environmental noise study.
Attenuation	The reduction of an acoustic signal.
A-Weighting	A frequency-response adjustment of a sound level meter that conditions the output signal to approximate human response.
Decibel or dB	Fundamental unit of sound. A Bell is defined as the logarithm of the ratio of the sound pressure squared over the reference pressure squared. A Decibel is one-tenth of a Bell.
CNEL	Community Noise Equivalent Level. Defined as the 24-hour average noise level with noise occurring during evening hours (7 - 10 p.m.) weighted by a factor of three and nighttime hours weighted by a factor of 10 prior to averaging.
Frequency	The measure of the rapidity of alterations of a periodic signal, expressed in cycles per second or hertz.
IIC	Impact Insulation Class (IIC): A single-number representation of a floor/ceiling partition's impact generated noise insulation performance. The field-measured version of this number is the FIIC.
L_{dn}	Day/Night Average Sound Level. Similar to CNEL but with no evening weighting.
Leq	Equivalent or energy-averaged sound level.
L_{max}	The highest root-mean-square (RMS) sound level measured over a given period of time.
Loudness	A subjective term for the sensation of the magnitude of sound.
Masking	The amount (or the process) by which the threshold of audibility is for one sound is raised by the presence of another (masking) sound.
Noise	Unwanted sound.
Peak Noise	The level corresponding to the highest (not RMS) sound pressure measured over a given period of time. This term is often confused with the "Maximum" level, which is the highest RMS level.
RT₆₀	The time it takes reverberant sound to decay by 60 dB once the source has been removed.
STC	Sound Transmission Class (STC): A single-number representation of a partition's noise insulation performance. This number is based on laboratory-measured, 16-band (1/3-octave) transmission loss (TL) data of the subject partition. The field-measured version of this number is the FSTC.

Attachment 9



Legend

- A** Noise survey location facing north towards project site
- B** Looking towards noise survey location near residential uses (equipment outlined in red)
- C** Noise survey location facing east towards Theatre Drive and U.S. 101

Peterbilt Service & Sales Center
Paso Robles, California

Noise Survey Photographs

Appendix B



Appendix C Long-Term Ambient Noise Monitoring Results Peterbilt Service and Sales Center - Paso Robles, California Monday, June 6, 2022 - Tuesday, June 7, 2022

Hour	Leq	Lmax	L50	L90
2:00 PM	52	68	50	48
3:00 PM	49	61	49	47
4:00 PM	50	63	49	48
5:00 PM	49	62	48	46
6:00 PM	53	66	53	49
7:00 PM	54	65	53	50
8:00 PM	52	62	51	48
9:00 PM	53	66	52	48
10:00 PM	51	60	50	46
11:00 PM	50	70	47	41
12:00 AM	47	58	45	41
1:00 AM	48	60	45	41
2:00 AM	45	59	43	39
3:00 AM	48	62	45	39
4:00 AM	52	64	50	44
5:00 AM	56	64	55	53
6:00 AM	55	64	55	52
7:00 AM	57	64	57	54
8:00 AM	56	63	55	53
9:00 AM	55	62	54	52
10:00 AM	55	65	54	51
11:00 AM	51	58	51	48
12:00 PM	55	69	52	49
1:00 PM	53	67	53	50

	Statistical Summary								
	Daytime (7 a.m. - 7 p.m.)			Evening (7 p.m. - 10 p.m.)			Nighttime (10 p.m. - 7 a.m.)		
	High	Low	Average	High	Low	Average	High	Low	Average
Leq (Average)	57	49	54	54	52	53	56	45	52
Lmax (Maximum)	69	58	64	66	62	64	70	58	62
L50 (Median)	57	48	52	53	51	52	55	43	48
L90 (Background)	54	46	50	50	48	48	53	39	44

Computed CNEL, dB	59
% Daytime Energy	59%
% Evening Energy	13%
% Nighttime Energy	28%

GPS Coordinates	35°34'38.28"N
	120°41'56.68"W

Appendix D
Long-Term Ambient Noise Monitoring Results
Peterbilt Service and Sales Center - Paso Robles, California
Monday, June 6, 2022 - Tuesday, June 7, 2022

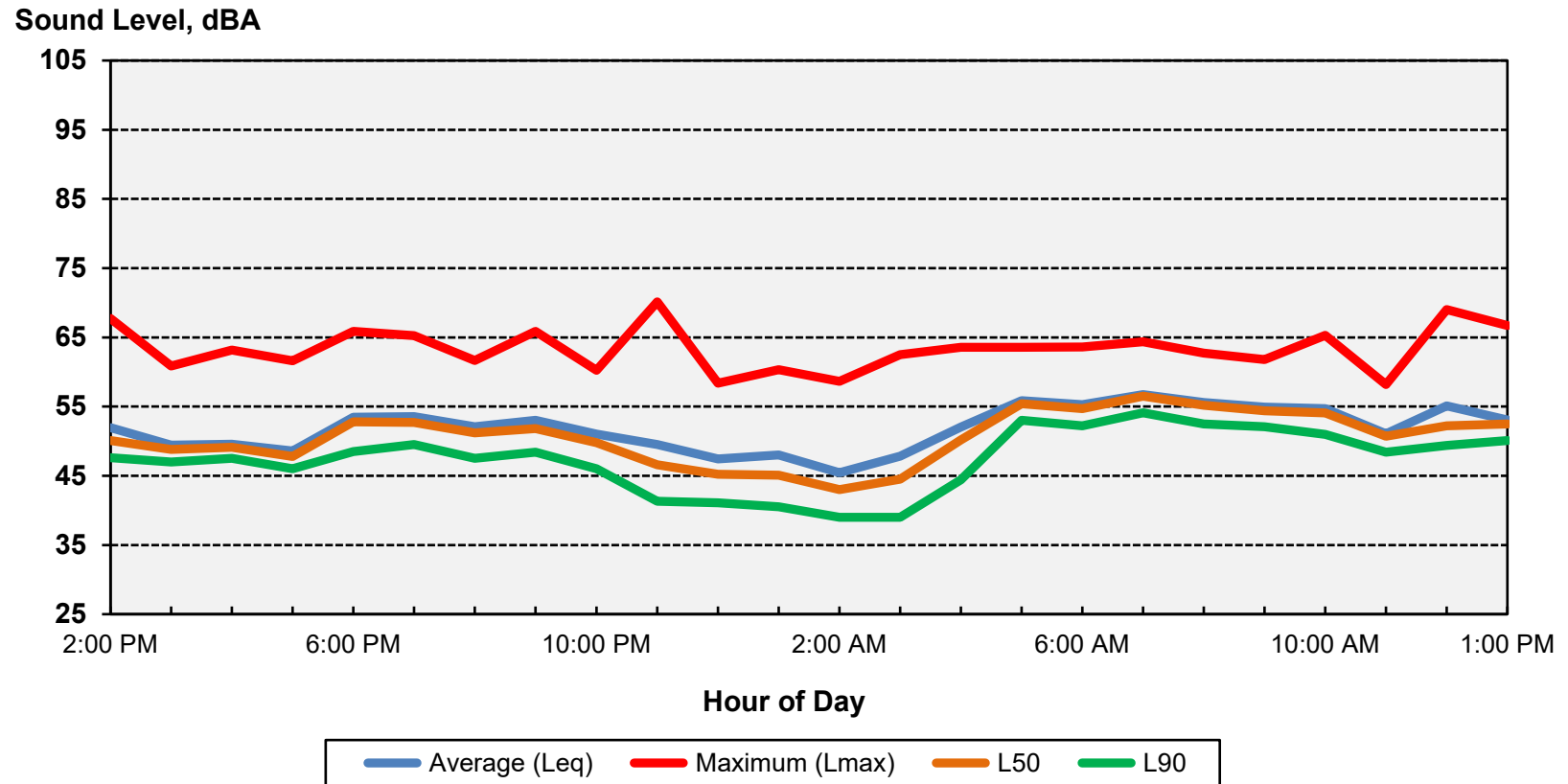

Computed CNEL = 59 dB



MEMORANDUM

Date: July 22, 2022
 To: David Athey and Kristin Ferravanti, City of Paso Robles
 From: Joe Fernandez and Korinne Tarien, CCTC
 Subject: **2805 Theatre Drive Peterbilt Dealership Transportation Analysis**

This memorandum summarizes the trip generation, safety, and vehicle miles traveled (VMT) evaluation of the 34,552 square foot building proposed at 2805 Theatre Drive in the City of Paso Robles. The building would be used for retail and services for semi-trucks and includes an on-site dealership. The site plan is shown on **Figure 1**.

The proposed project is expected to have a less-than-significant impact to VMT.

We recommend the driveway widths be reduced to meet City standards and that the Theatre Drive improvements are constructed to accommodate two travel lanes, bike lanes, and a center left turn lane. We also recommend parking on Nutwood Circle be restricted on both sides of the road from the curb return to 20 feet west.

TRIP GENERATION

The proposed project does not conform to standard uses in the Institute of Transportation Engineers' Trip Generation Manual. Accordingly, new traffic counts were conducted at a similar facility operated by the applicant in Salinas. Like the proposed project, the Salinas facility is located near US 101 and offers similar services in a similar sized building. **Table 1** below summarizes the trip counts collected at the Salinas facility, with detailed count sheets attached.

Table 1: Peterbilt Trip Generation (Elvee Drive, Salinas)

Elvee Drive Trip Generation							
Land Use	Daily Total	AM Peak Hour			PM Peak Hour		
		In	Out	Total	In	Out	Total
Peterbilt - Salinas	178	28	13	41	19	26	45
Source: Metro Traffic Data, CCTC, 2022.							

The collected data shows that the Salinas facility generates approximately 178 daily, 41 AM, and 45 PM peak hour trips. It is assumed that the proposed project would generate a similar number of trips with fewer than 50 peak hour trips. These trips are likely to be roughly evenly split between the north and the south, gaining access to US 101 via the SR 46W and Main Street interchanges.

CEQA ANALYSIS

Vehicle miles traveled (VMT) were analyzed consistent with recently mandated changes to the California Environmental Quality Act (CEQA) and state Office of Planning and Research (OPR) guidance. The City's 2022 Transportation Impact Analysis (TIA) Guidelines Supplement provide VMT and safety thresholds consistent with OPR guidance. Office and industrial projects may have a significant impact if the work VMT per employee exceeds 85 percent of the regional average. Work VMT captures home-based-work attractions (trips from homes to workplaces).

The SLOCOG Travel Demand Model was applied to estimate VMT. Project employees were estimated using typical square footage per employee from industry standard sources, then were added to the model. **Table 2** summarizes the VMT results.

Table 2: Regional VMT Analysis

Regional VMT Analysis		
Scenario	Regional Employees	Regional Work VMT
2020 No Project	117,335	1,595,867
2020 With Project	117,373	1,596,553
<i>Change from No Project</i>	<i>38</i>	<i>686</i>
1. Work VMT is attracted to workplaces (sum of home-based-work attractions). Threshold calculated as 85% of regional average. Source: SLOCOG TDM, CCTC, 2022		

The regional average work VMT per employee is 13.60 (1,595,867/117,335). A threshold of 85% of this level corresponds to 11.56 work VMT per employee. The project is forecast to have a work VMT per employee of 3.3, well below the threshold. This is due to the provision of jobs in a housing-rich area. Therefore, the project would have a less-than-significant impact to VMT.

Projects may also have a significant impact if they exacerbate an existing high-priority or similar safety location, introduce a design feature that substantially increases hazards, or propose features that do not meet City design standards.

Collision data was obtained from the Statewide Integrated Traffic Records System (SWITRS) for Templeton CHP and City police on Theatre Drive in the vicinity of the project between 2017 and 2021. One injury collision occurred near Ranch Paso Road when a bicycle was traveling the wrong way. No collisions occurred at or near Nutwood Circle. There are no observed collision patterns and no recommendations.

SITE ACCESS AND ON SITE CIRCULATION

The project proposes two driveways one on Theater Drive and one on Nutwood Circle. The proposed driveway on Theatre Drive is 50 feet wide, larger than a standard commercial driveway. City Standard Drawing C-9 specifies a maximum driveway width of 30 feet. We recommend both driveways meet City Standards.

The project will be required to complete frontage improvements on Theatre Drive as currently shown on the site plan in **Figure 1**. The City and County Bike Plans include future Class II bike lanes on Theatre Drive. We recommend the Theatre Drive frontage improvements be designed to accommodate two travel lanes, bike lanes, and a center left turn lane. Parking is not recommended on Theatre Drive. We also recommend parking on Nutwood Circle be restricted on both sides of the road from the curb return to 20 feet west consistent with the California Manual on Uniform Traffic Control Devices (CAMUTCD).

Please let us know if you have any questions.

ATTACHMENTS

Site Plan Figure

Salinas Peterbilt Counts

Figure 1 - Site Plan

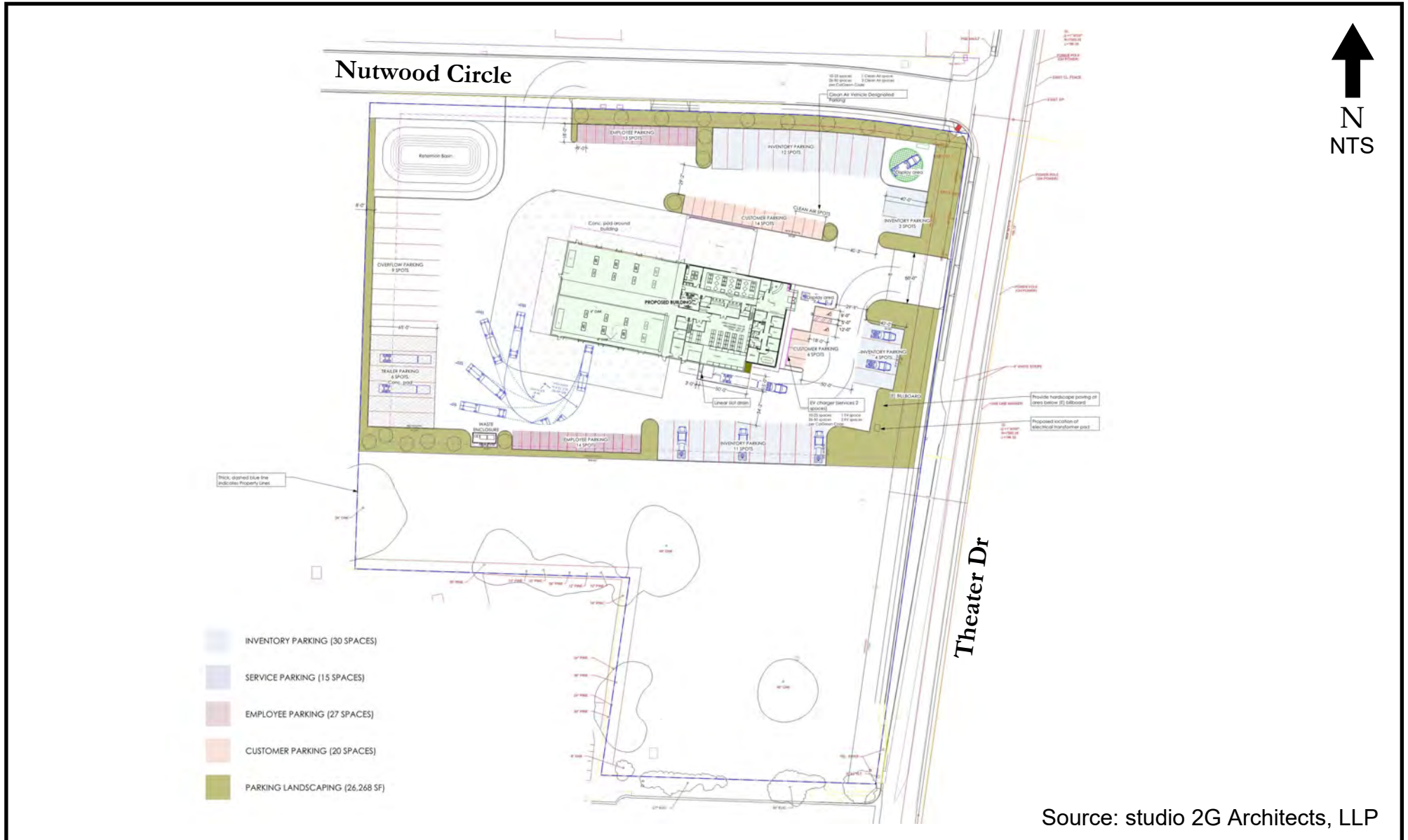

24 Hour Count Report



Metro Traffic Data Inc.
 310 N. Irwin Street - Suite 20
 Hanford, CA 93230
 800-975-6938 Phone/Fax
 www.metrotrafficdata.com

Prepared For: **Central Coast Transportation Consulting**
 895 Napa Avenue, Suite A-6
 Morro Bay, CA 93442

LOCATION Elvee Dr @ Peterbilt Western Driveway

LATITUDE 36.6673123

COUNTY Monterey

LONGITUDE -121.6312846

COLLECTION DATE Thursday, June 2, 2022

WEATHER Clear

NUMBER OF LANES 2

Hour	Inbound					Outbound					Hourly Totals
	1st	2nd	3rd	4th	Total	1st	2nd	3rd	4th	Total	
12:00 AM	0	0	0	0	0	0	0	0	0	0	0
1:00 AM	0	0	0	0	0	0	0	0	0	0	0
2:00 AM	0	0	0	0	0	0	0	0	0	0	0
3:00 AM	0	0	0	0	0	0	0	0	0	0	0
4:00 AM	0	0	0	0	0	0	0	0	0	0	0
5:00 AM	0	0	0	0	0	0	0	0	0	0	0
6:00 AM	0	0	0	0	0	0	0	0	0	0	0
7:00 AM	0	1	0	1	2	1	1	1	1	4	6
8:00 AM	1	1	3	1	6	0	1	0	2	3	9
9:00 AM	0	0	0	0	0	0	0	0	0	0	0
10:00 AM	0	0	0	0	0	0	0	0	0	0	0
11:00 AM	0	0	0	0	0	0	0	0	0	0	0
12:00 PM	0	0	0	0	0	0	0	0	0	0	0
1:00 PM	0	0	0	0	0	0	0	0	0	0	0
2:00 PM	0	0	0	0	0	0	0	0	0	0	0
3:00 PM	1	1	2	2	6	1	0	0	4	5	11
4:00 PM	2	4	0	1	7	3	1	5	2	11	18
5:00 PM	0	1	0	0	1	0	0	0	0	0	1
6:00 PM	0	0	0	0	0	0	0	0	0	0	0
7:00 PM	0	0	0	0	0	0	0	0	0	0	0
8:00 PM	0	0	0	0	0	0	0	0	0	0	0
9:00 PM	0	0	0	0	0	0	0	0	0	0	0
10:00 PM	0	0	0	0	0	0	0	0	0	0	0
11:00 PM	0	0	0	0	0	0	0	0	0	0	0
Total	48.9%				22	51.1%				23	45

AM% **33.3%** AM Peak **14** 8:00 am to 9:00 am AM P.H.F. **0.70**
 PM% **66.7%** PM Peak **32** 4:30 pm to 5:30 pm PM P.H.F. **0.67**

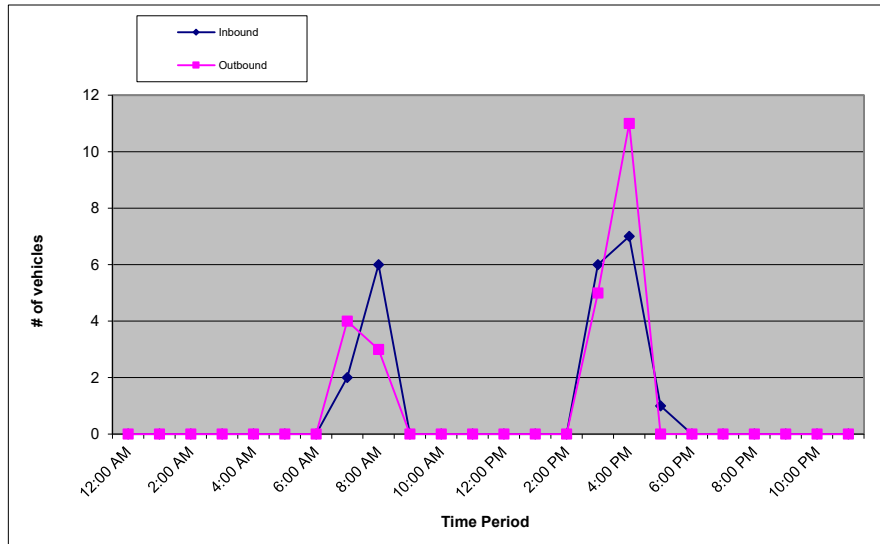

24 Hour Count Report



Metro Traffic Data Inc.
 310 N. Irwin Street - Suite 20
 Hanford, CA 93230
 800-975-6938 Phone/Fax
 www.metrotrafficdata.com

Prepared For: **Central Coast Transportation Consulting**
 895 Napa Avenue, Suite A-6
 Morro Bay, CA 93442

LOCATION Elvee Dr @ Peterbilt Eastern Driveway

LATITUDE 36.666952

COUNTY Monterey

LONGITUDE -121.6301178

COLLECTION DATE Thursday, June 2, 2022

WEATHER Clear

NUMBER OF LANES 2

Hour	Inbound					Outbound					Hourly Totals
	1st	2nd	3rd	4th	Total	1st	2nd	3rd	4th	Total	
12:00 AM	0	0	0	0	0	0	0	0	0	0	0
1:00 AM	0	0	0	0	0	0	0	0	0	0	0
2:00 AM	0	0	0	0	0	0	0	0	0	0	0
3:00 AM	0	0	0	0	0	0	0	0	0	0	0
4:00 AM	0	0	0	0	0	0	0	0	0	0	0
5:00 AM	0	0	0	0	0	0	0	0	0	0	0
6:00 AM	0	0	0	0	0	0	0	0	0	0	0
7:00 AM	2	5	6	13	26	0	2	5	2	9	35
8:00 AM	5	2	6	2	15	2	2	4	3	11	26
9:00 AM	0	0	0	0	0	0	0	0	0	0	0
10:00 AM	0	0	0	0	0	0	0	0	0	0	0
11:00 AM	0	0	0	0	0	0	0	0	0	0	0
12:00 PM	0	0	0	0	0	0	0	0	0	0	0
1:00 PM	0	0	0	0	0	0	0	0	0	0	0
2:00 PM	0	0	0	0	0	0	0	0	0	0	0
3:00 PM	0	5	3	2	10	5	1	6	2	14	24
4:00 PM	4	7	0	1	12	5	4	4	2	15	27
5:00 PM	0	1	0	0	1	12	7	0	1	20	21
6:00 PM	0	0	0	0	0	0	0	0	0	0	0
7:00 PM	0	0	0	0	0	0	0	0	0	0	0
8:00 PM	0	0	0	0	0	0	0	0	0	0	0
9:00 PM	0	0	0	0	0	0	0	0	0	0	0
10:00 PM	0	0	0	0	0	0	0	0	0	0	0
11:00 PM	0	0	0	0	0	0	0	0	0	0	0
Total	48.1%				64	51.9%				69	133

AM% **45.9%** AM Peak **98** 5:30 am to 6:30 am AM P.H.F. **0.58**
 PM% **54.1%** PM Peak **37** 3:00 pm to 4:00 pm PM P.H.F. **0.93**

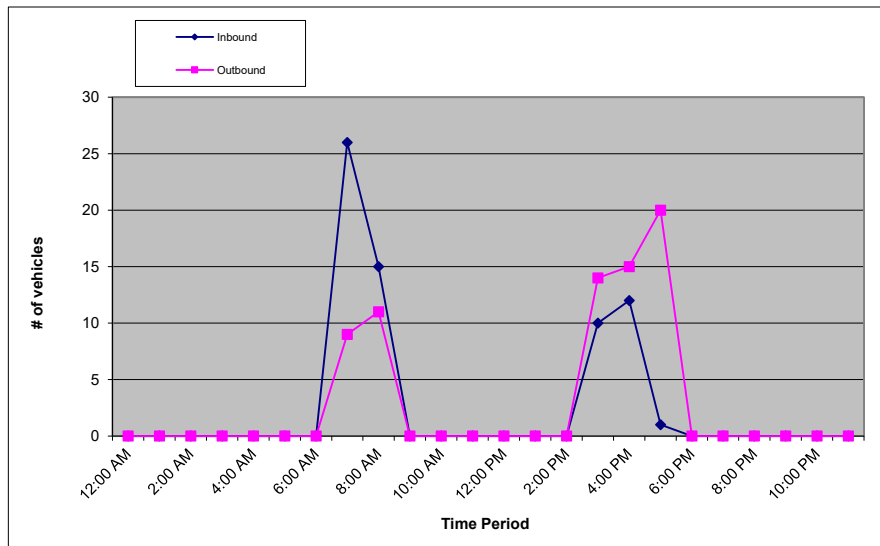

Exhibit A

Mitigation Monitoring and Reporting Plan

Project File No./Name: **Peterbilt Sales and Service Center**

Approving Resolution No.: _____ by: Planning Commission City Council

Date: June 20, 2023

The following environmental mitigation measures were either incorporated into the approved plans or will be incorporated into the conditions of approval. Each and every mitigation measure listed below has been found by the approving body indicated above to lessen the level of environmental impact of the project to a level of non-significance. A completed and signed checklist for each mitigation measure indicates that it has been completed.

Explanation of Headings:

Type: Project, ongoing, cumulative

Monitoring Department or Agency: Department or Agency responsible for monitoring a particular mitigation measure

Shown on Plans: When a mitigation measure is shown on the plans, this column will be initialed and dated.

Verified Implementation: When a mitigation measure has been implemented, this column will be initialed and dated.

Remarks: Area for describing status of ongoing mitigation measure, or for other information.

Mitigation Measure PD22-02 / CUP22-16 / RZN22-03 / P22-0017 and CUP23-03 / P23-0019 (Peterbilt and Outfront Media)	Type	Monitoring Department or Agency	Shown on Plans	Verified Implementation	Timing/Remarks
AES-1. Any lights installed to illuminate the billboard shall be external and shielded so that the light source is not visible from roadways or properties zoned for residential use. The applicant shall use the least amount of light practicable for the purpose of illuminating the sign. The applicant shall provide a photometric plan before issuance of a building permit to demonstrate the proposed lighting will not spill onto any residentially zoned property.	Project	City of Paso Robles Community Development Department (CDD)	X	Field inspection.	Prior to final building inspection / occupancy of the building
AES-2. The freeway-oriented sign shall not exceed 30 feet in height.	Project	CDD	X	Field inspection.	Prior to final building inspection / occupancy of the building

Exhibit A

<p style="text-align: center;">Mitigation Measure PD22-02 / CUP22-16 / RZN22-03 / P22-0017 and CUP23-03 / P23-0019 (Peterbilt and Outfront Media)</p>	<p style="text-align: center;">Type</p>	<p style="text-align: center;">Monitoring Department or Agency</p>	<p style="text-align: center;">Shown on Plans</p>	<p style="text-align: center;">Verified Implementation</p>	<p style="text-align: center;">Timing/Remarks</p>
<p>AES-3. Any future freeway-oriented sign for a business developed on the southern portion of the lot shall be collocated on the same sign structure as the freeway-oriented sign for the Peterbilt project.</p>	<p>Cumulative</p>	<p>CDD</p>	<p>X</p>		<p>Before planning submittal for undeveloped area</p>
<p>AES-4. The applicant shall provide and maintain landscaping and street trees along the entire length of both street frontages to the satisfaction of the Director of the Community Development Department. Street trees are not required on the remainder portion of the lot.</p>	<p>Project</p>	<p>CDD</p>	<p>X</p>	<p>Landscaping plan. Field Inspection.</p>	<p>Prior to final building inspection / occupancy of the building</p>
<p>AQ-1. Maintain all construction equipment in proper tune according to manufacturer’s specifications.</p>	<p>Project</p>	<p>CDD</p>	<p>X</p>	<p>Notes shown on construction documents.</p>	<p>Prior to issuance of grading permit</p>
<p>AQ-2. Fuel all off-road and portable diesel-powered equipment with California Air Resources Board (CARB) certified motor vehicle diesel fuel (non-taxed version suitable for use off-road.</p>	<p>Project</p>	<p>CDD</p>	<p>X</p>	<p>Notes shown on construction documents.</p>	<p>Prior to issuance of grading permit</p>
<p>AQ-3. Use diesel construction equipment meeting CARB's Tier 2 certified engines or cleaner off-road heavy-duty diesel engines, and comply with the State off-Road Regulation.</p>	<p>Project</p>	<p>CDD</p>	<p>X</p>	<p>Notes shown on construction documents.</p>	<p>Prior to issuance of grading permit</p>

Exhibit A

Mitigation Measure PD22-02 / CUP22-16 / RZN22-03 / P22-0017 and CUP23-03 / P23-0019 (Peterbilt and Outfront Media)	Type	Monitoring Department or Agency	Shown on Plans	Verified Implementation	Timing/Remarks
AQ-4. Use on-road heavy-duty trucks that meet the CARB’s 2010 or cleaner certification standard for on-road heavy-duty diesel engines, and comply with the State On-Road Regulation.	Project	CDD	X	Notes shown on construction documents.	Prior to issuance of grading permit
AQ-5. All on and off-road diesel equipment shall not idle for more than 5 minutes. Signs shall be posted in the designated queuing areas and or job sites to remind drivers and operators of the 5-minute idling limit.	Project	CDD	X	Notes shown on construction documents. Site inspection of signs.	Prior to issuance of grading permit Prior to issuance of grading permit
AQ-6. All projects with diesel-powered construction activity shall comply with Section 2485 of Title 13 of the California Code of Regulations and the 5-minute idling restriction identified in Section 2449(d)(2) of the California Air Resources Board’s In-Use Off-Road Diesel regulation to minimize toxic air pollution impacts from idling diesel engines. The specific requirements and exceptions for the on-road and off-road regulations can be reviewed at the following web sites: arb.ca.gov/sites/default/files/classic/msprog/truck-idling and arb.ca.gov/regact/2007/ordiesl07/frooal.pdf	Project	CDD	X	Notes shown on construction documents. Site inspection of signs.	Prior to issuance of a grading permit
AQ-7. Diesel idling within 1,000 feet of sensitive receptors is not permitted.	Project	CDD	X	Notes shown on construction documents.	Prior to issuance of grading permit

Exhibit A

Mitigation Measure PD22-02 / CUP22-16 / RZN22-03 / P22-0017 and CUP23-03 / P23-0019 (Peterbilt and Outfront Media)	Type	Monitoring Department or Agency	Shown on Plans	Verified Implementation	Timing/Remarks
AQ-8. Staging and queuing areas shall not be located within 1,000 feet of sensitive receptors.	Project	CDD	X	Notes shown on construction documents.	Prior to issuance of grading permit
AQ-9. The applicant shall post and enforce no idling areas at the site.	Project	CDD	X	Notes shown on construction documents.	Prior to issuance of a grading permit
AQ-10. Electrify equipment when feasible.	Project	CDD	X	Notes shown on construction documents.	Prior to issuance of grading permit
AQ-11. Substitute gasoline-powered in place of diesel-powered equipment, where feasible.	Project	CDD	X	Notes shown on construction documents.	Prior to issuance of grading permit
AQ-12. Use alternatively fueled construction equipment on-site where feasible, such as compressed natural gas (CNG), liquefied natural gas (LNG), propane or biodiesel.	Project	CDD	X	Notes shown on construction documents.	Prior to issuance of grading permit
AQ-13. Diesel equipment used to construct the site shall install California Verified Diesel Emission Control Strategies listed at: http://www.arb.ca.gov/diesel/verdev/vt/cvt.htm .	Project	CDD	X	Notes shown on construction documents.	Prior to issuance of grading permit
AQ-14. 15% of construction fleet vehicles shall be zero emission vehicles.	Project	CDD	X	Notes shown on construction documents.	Prior to issuance of grading permit
AQ-15. The project shall include alternative fuel fleet vehicle(s).	Project	CDD	X	Notes shown on construction documents.	Prior to issuance of grading permit

Exhibit A

Mitigation Measure PD22-02 / CUP22-16 / RZN22-03 / P22-0017 and CUP23-03 / P23-0019 (Peterbilt and Outfront Media)	Type	Monitoring Department or Agency	Shown on Plans	Verified Implementation	Timing/Remarks
AQ-16. The project shall reduce the amount of disturbed area where possible.	Project	CDD	X	Notes shown on construction documents.	Prior to issuance of grading permit
AQ-17. The project shall use water trucks or sprinkler systems in sufficient quantities to prevent airborne dust from leaving the site and from exceeding the APCD’s limit of 20% opacity for greater than 3 minutes in any 60-minute period. Increased watering frequency is required whenever wind speeds exceed 15 mph. Reclaimed (non-potable) water shall be used whenever possible. When drought conditions exist and water use is a concern, the contractor or builder shall consider use of a dust suppressant that is effective for the specific site conditions to reduce the amount of water used for dust control. Refer to http://www.valleyair.org/busind/comply/PM10/Product%20Available%20for%20Controlling%20PM10%20Emissions.htm for a list of potential dust suppressants.	Project	CDD	X	Notes shown on construction documents. Site inspections.	Prior to issuance of grading permit
AQ-18. All dirt stock-pile areas shall be sprayed daily and covered with tarps or other barriers as needed.	Project	CDD	X	Notes shown on construction documents. Site inspections.	Prior to issuance of grading permit
AQ-19. Permanent dust control measures identified in the approved project revegetation and landscape plans shall be implemented as soon as possible following completion of any soil disturbing activities.	Project	CDD	X	Notes shown on construction documents.	Prior to issuance of grading permit

Exhibit A

Mitigation Measure PD22-02 / CUP22-16 / RZN22-03 / P22-0017 and CUP23-03 / P23-0019 (Peterbilt and Outfront Media)	Type	Monitoring Department or Agency	Shown on Plans	Verified Implementation	Timing/Remarks
AQ-20. Exposed ground areas that are planned to be reworked at dates greater than one month after initial grading shall be sown with a fast germinating, non-invasive grass seed and watered until vegetation is established.	Project	CDD	X	Notes shown on construction documents.	Prior to issuance of grading permit
AQ-21. All disturbed soil areas not subject to revegetation shall be stabilized using approved chemical soil binders, jute netting, or other methods approved in advance by the APCD.	Project	CDD	X	Notes shown on construction documents.	Prior to issuance of grading permit
AQ-22. All roadways, driveways, sidewalks, etc. to be paved shall be completed as soon as possible. In addition, building pads should be laid as soon as possible after grading unless seeding or soil binders are used.	Project	CDD	X	Notes shown on construction documents.	Prior to issuance of grading permit
AQ-23. Vehicle speed for all construction vehicles shall not exceed 15 mph on any unpaved surface at the construction site.	Project	CDD	X	Notes shown on construction documents.	Prior to issuance of grading permit
AQ-24. All trucks hauling dirt, sand, soil, or other loose materials shall be covered or shall maintain at least two feet of freeboard (minimum vertical distance between top of load and top of trailer) in accordance with CVC Section 23114.	Project	CDD	X	Notes shown on construction documents.	Prior to issuance of grading permit

Exhibit A

Mitigation Measure PD22-02 / CUP22-16 / RZN22-03 / P22-0017 and CUP23-03 / P23-0019 (Peterbilt and Outfront Media)	Type	Monitoring Department or Agency	Shown on Plans	Verified Implementation	Timing/Remarks
AQ-25. The applicant shall sweep streets at the end of each day if visible soil material is carried onto adjacent paved roads. Water sweepers with reclaimed water shall be used where feasible. Roads shall be pre-wetted prior to sweeping when feasible.	Project	CDD	X	Notes shown on construction documents. Site Inspections.	Prior to issuance of grading permit
AQ-26. The applicant shall install wheel washers where vehicles enter and exit unpaved roads onto streets or wash off trucks and equipment leaving the site.	Project	CDD	X	Notes shown on construction documents. Site inspections.	Prior to issuance of grading permit
AQ-27. The contractor or builder shall designate a person or persons whose responsibility is to ensure any to monitor the fugitive dust emissions do not result in a nuisance and to enhance the implementation of the mitigation measures as necessary to minimize dust complaints, and reduce visible emissions below the APCD’s limit of 20% opacity for greater than 3 minutes in any 60-minute period, and to prevent transport of dust offsite. Their duties shall include holidays and weekend periods when work may not be in progress (for example, wind-blown dust could be generated on an open dirt lot). The name and telephone number of such persons shall be provided to the APCD Compliance Division prior to the start of any grading, earthwork, or	Project	CDD	X	Notes shown on construction documents.	Prior to issuance of grading permit

Exhibit A

Mitigation Measure PD22-02 / CUP22-16 / RZN22-03 / P22-0017 and CUP23-03 / P23-0019 (Peterbilt and Outfront Media)	Type	Monitoring Department or Agency	Shown on Plans	Verified Implementation	Timing/Remarks
demolition (Contact the Compliance Division at 805-781-5912).					
AQ-28. The applicant shall take additional measures as needed to ensure dust from the project site does not impact areas outside the project boundary.	Project	CDD	X	Notes shown on construction documents.	Prior to issuance of grading permit
AQ-29. To prevent ‘track out’ (sand or soil that adheres to and/or agglomerates on the exterior surfaces of motor vehicles and/or equipment (including tires) that may then fall onto any highway or street as described in CVC Section 23113 and California Water Code 13304), the applicant shall designate access points and require all employees, subcontractors, and others to use them. The applicant shall install and operate a ‘track-out prevention device’ where vehicles enter and exit unpaved roads onto paved streets. The ‘track-out prevention device’ can be any device or combination of devices that are effective at preventing track out, located at the point of intersection of an unpaved area and a paved road. Rumble strips or steel plate devices need periodic cleaning to be effective. If paved roadways accumulate tracked out soils, the track-out prevention device may need to be modified.	Project	CDD	X	Notes shown on construction documents.	Prior to issuance of grading permit
AQ-30. All fugitive dust mitigation measures shall be shown on grading and building plans.	Project	CDD	X	Notes shown on construction documents.	Prior to issuance of grading permit

Exhibit A

Mitigation Measure PD22-02 / CUP22-16 / RZN22-03 / P22-0017 and CUP23-03 / P23-0019 (Peterbilt and Outfront Media)	Type	Monitoring Department or Agency	Shown on Plans	Verified Implementation	Timing/Remarks
AQ-31. The applicant shall acquire all required APCD permits for portable equipment greater than 50 hp used during construction activities.	Project	CDD and APCD	X	Submittal with construction documents.	Prior to issuance of grading permit
AQ-32. The applicant shall acquire all required APCD permits for operational stationary diesel engines greater than 50 hp.	Project	CDD and APCD	X	Submittal with construction documents.	Prior to issuance of grading permit
AQ-33. Before issuance of a building permit, the applicant shall prepare a screening-level health risk assessment with risk screening inputs including: <ul style="list-style-type: none"> • Daily operational phase trips to the project site; • % of daily trips that are diesel trucks and their anticipated make up (i.e. heavy-heavy duty, medium-heavy duty, light-heavy duty); • Total daily diesel trips to site; • Number of days per year project location will be open; • Total annual diesel trips; and • Distance from midpoint of truck service center to lot of nearest sensitive receptor. 	Project	CDD and APCD	X	Submittal with construction documents.	Prior to issuance of grading permit

Exhibit A

Mitigation Measure PD22-02 / CUP22-16 / RZN22-03 / P22-0017 and CUP23-03 / P23-0019 (Peterbilt and Outfront Media)	Type	Monitoring Department or Agency	Shown on Plans	Verified Implementation	Timing/Remarks
<p>If the screening assessment is above 10 in a million, a more comprehensive health risk analysis shall be required. Results of the screening and/or the refined health risk assessment shall be provided to the APCD for review and approval.</p>					
<p>AQ-34. Developmental burning of vegetative material is prohibited.</p>	Project	CDD	X		Ongoing
<p>BIO-1. All construction work activities shall be completed during daylight hours (between sunrise and sunset) and outside of rain events.</p>	Project	CDD	X	Notes shown on construction documents.	Prior to issuance of grading permit
<p>BIO-2. The Project impact area shall be clearly marked or delineated with stakes, flagging, tape, or signage prior to work. Areas outside of work limits shall be considered environmentally sensitive and shall not be disturbed.</p>	Project	CDD	X	Notes shown on construction documents. Site inspection.	Prior to issuance of grading permit.
<p>BIO-3. All equipment and vehicles shall be checked and maintained daily to prevent spills of fuel, oil, and other hazardous materials. A designated staging area shall be established for vehicle/equipment parking and storage of fuel, lubricants, and solvents. All fueling and</p>	Project	CDD	x	Notes shown on construction documents. Site Inspection.	Prior to issuance of grading permit

Exhibit A

Mitigation Measure PD22-02 / CUP22-16 / RZN22-03 / P22-0017 and CUP23-03 / P23-0019 (Peterbilt and Outfront Media)	Type	Monitoring Department or Agency	Shown on Plans	Verified Implementation	Timing/Remarks
maintenance activities shall take place in the staging area.					
BIO-4. If vegetation removal (i.e., tree trimming/removal activities) is scheduled between February 1 and August 31 (general nesting bird season), nesting bird surveys shall be completed by a qualified biologist within 48 hours prior to start of work. If any active nests are discovered within or adjacent to work limits, an appropriate buffer (i.e., 500 feet for raptors and 250 feet for other birds, or at the discretion of a qualified biologist based on biological or ecological reasons) shall be established to protect the nest until a qualified biologist has determined that the nest is no longer active and/or the young have fledged.	Project	CDD	X	Notes shown on construction documents. Site inspection	Prior to issuance of grading permit
BIO-5. Within 30 days of the start of construction, a qualified biologist shall conduct a pre-activity survey of the Project Site for signs of San Joaquin kit fox and American badger, including tracks, scat, or suitable burrows (burrows four inches or greater in diameter). Potential dens shall be tracked for a minimum of four nights with motion-activated cameras to determine if the burrow is actively being used by San Joaquin kit fox or badger. All potential dens shall be avoided by a minimum of 50 feet until they have been determined to be inactive. In the event San Joaquin kit fox is identified	Project	CDD	X	Notes shown on construction documents.	Prior to issuance of grading permit

Exhibit A

Mitigation Measure PD22-02 / CUP22-16 / RZN22-03 / P22-0017 and CUP23-03 / P23-0019 (Peterbilt and Outfront Media)	Type	Monitoring Department or Agency	Shown on Plans	Verified Implementation	Timing/Remarks
<p>within the Project Site, the USFWS, CDFW, and all other appropriate agencies/government entities shall be contacted for further consultation.</p> <p>In conjunction with the badger and kit fox survey, the qualified biologist will conduct a survey for Northern legless lizard. Hand search methods, including raking, will be used during the survey in areas where legless lizards are expected to be found (e.g., sandy/loose soils, under shrubs/leaf litter, other vegetation, or debris). If observed, the qualified biologist will relocate the lizard to nearby suitable habitat. The qualified biologist will prepare a completion letter-report to document the pre-activity survey results.</p>					
<p>BIO-6. If oak tree removal and/or damage is unavoidable due to Project implementation, 25% of the diameter of trees removed shall be replanted on the site.</p>	Project	CDD	X	Notes shown on construction documents. Site inspection.	Prior to issuance of grading permit and building permit and ongoing during the duration of construction.
<p>CUL-1. In the event that buried or otherwise unknown cultural resources are discovered during construction work in the area of the find shall be suspended and the City of Paso Robles shall be contacted immediately, and appropriate mitigations measures shall be developed by qualified archeologist or historian if necessary, at the developers expense.</p>	Project	CDD	X	Notes on construction documents.	Prior to issuance of grading and building permits.

Exhibit A

Mitigation Measure PD22-02 / CUP22-16 / RZN22-03 / P22-0017 and CUP23-03 / P23-0019 (Peterbilt and Outfront Media)	Type	Monitoring Department or Agency	Shown on Plans	Verified Implementation	Timing/Remarks
CUL-2. In the event human remains are found on the project site during construction or during archaeological work, the person responsible for the excavation, or his or her authorized representative, shall immediately notify the San Luis Obispo County Coroner’s office by telephone. No further excavation or disturbance of the discovery or any nearby area reasonably suspected to overlie adjacent remains (as determined by the qualified archaeologist and/or the Native American monitor) shall occur until the Coroner has made the necessary findings as to origin and disposition. If the Coroner recognizes the remains to be Native American, he or she shall contact the Native American Heritage Commission (NAHC) within 24 hours. The NAHC would make a determination as to the Most Likely Descendent.	Project	SLO County Coroner, Native American Heritage Commission	X	As needed	Ongoing during grading and construction.
GEO-1. The applicant shall provide a soils report for the project.	Project	CDD	X	Shown on building plans.	Before building permit issuance.
GEO-2. The applicant shall provide a stormwater pollution prevention plan (SWPPP) for the project.	Project	CDD	X	Shown on building plans.	Before building permit issuance.
GHG-1. The applicant shall submit a plan to reduce greenhouse gas emissions to below the applicable GHG significance threshold (1.9 MTCO _{2e} /service population/year or other adopted GHG significance threshold). The plan shall incorporate GHG-reduction	Project	CDD	X	Ongoing	Plan submitted before building permit issuance. Monitoring ongoing.

Exhibit A

Mitigation Measure PD22-02 / CUP22-16 / RZN22-03 / P22-0017 and CUP23-03 / P23-0019 (Peterbilt and Outfront Media)	Type	Monitoring Department or Agency	Shown on Plans	Verified Implementation	Timing/Remarks
<p>measures that may include, but are not limited to the following list.</p> <p>Onsite mitigation measures shall be the first priority of the GHG Reduction Plan, including but not limited to:</p> <ul style="list-style-type: none"> a. Receive electricity from onsite solar, Central Coast Community Energy (3CE) 3Cprime Service, or a combination thereof. b. Design roof structural members to handle dead weight loads of solar-heated water and photovoltaic panels. c. Install only Energy Star certified or equivalent and electrically powered mechanical equipment and appliances (not natural gas). d. Implement on-site circulation design elements in parking lots to reduce vehicle queuing and improve the pedestrian environment. e. Exceed Cal Green standards by 25% for providing on-site bicycle parking: both short-term racks and long-term lockers, or a locked room with standard racks and access limited to bicyclists only. f. Provide improved public transit amenities (e.g.: covered transit turnouts, direct pedestrian access, bicycle racks, covered bench, smart 					

Exhibit A

<p style="text-align: center;">Mitigation Measure PD22-02 / CUP22-16 / RZN22-03 / P22-0017 and CUP23-03 / P23-0019 (Peterbilt and Outfront Media)</p>	<p style="text-align: center;">Type</p>	<p style="text-align: center;">Monitoring Department or Agency</p>	<p style="text-align: center;">Shown on Plans</p>	<p style="text-align: center;">Verified Implementation</p>	<p style="text-align: center;">Timing/Remarks</p>
<p>signage, route information displays, lighting, etc.).</p> <p>g. Require 15% of fleet vehicles to be zero emission vehicles.</p> <p>h. Require fleet vehicle(s) to include alternative fuel vehicles.</p> <p>i. Provide dedicated parking for carpools, vanpools, and/or high-efficiency vehicles to meet or exceed Cal Green Tier 2.</p> <p>j. Provide vanpool, shuttle, mini bus service (alternative fueled preferred).</p> <p>k. Work with SLO Regional Rideshare to educate occupants with alternative transportation and smart commute information (e.g. transportation board, electronic kiosk, new hire packets, web portal, newsletters, social media, etc.).</p> <p>l. Implement programs to reduce employee vehicle miles traveled (e.g. incentives, SLO Regional Rideshare trip reduction program, vanpools, onsite employee housing, alternative schedules (e.g. 9-80s, 4-10s, telecommuting, satellite work sites, etc.).</p> <p>m. Provide a lunchtime shuttle to reduce single occupant vehicle trips and/or coordinate regular food truck visits.</p> <p>n. Provide delivery service in clean fueled vehicles.</p>					

Exhibit A

<p style="text-align: center;">Mitigation Measure PD22-02 / CUP22-16 / RZN22-03 / P22-0017 and CUP23-03 / P23-0019 (Peterbilt and Outfront Media)</p>	<p style="text-align: center;">Type</p>	<p style="text-align: center;">Monitoring Department or Agency</p>	<p style="text-align: center;">Shown on Plans</p>	<p style="text-align: center;">Verified Implementation</p>	<p style="text-align: center;">Timing/Remarks</p>
<p>o. Implement a “No Idling” vehicle program which includes signage, enforcement, etc.</p> <p>p. Meet or exceed Cal Green Tier 2 standards for providing EV charging infrastructure.</p> <p>q. Install 1 or more level 2 or better EV charging stations.</p> <p>r. Meet or exceed Cal Green Tier 2 standards for building energy efficiency.</p> <p>s. Use battery powered or electric landscape maintenance equipment.</p> <p>t. Use paints and cleaning products that are low-VOC content (e.g., 50 grams/liter VOC content, or less).</p> <p>Offsite measures within San Luis Obispo County shall be the second priority of the GHG Reduction Plan, including but not limited to:</p> <p>u. Work with SLOCOG to create, improve, or expand a nearby 'Park and Ride' lot with car parking and bike lockers in proportion to the size of the project.</p> <p>v. Implement SLO County generated offsets compliant with a protocol approved by the California Air Resources Board (CARB).</p>					

Exhibit A

Mitigation Measure PD22-02 / CUP22-16 / RZN22-03 / P22-0017 and CUP23-03 / P23-0019 (Peterbilt and Outfront Media)	Type	Monitoring Department or Agency	Shown on Plans	Verified Implementation	Timing/Remarks
<p>Offsite measures within California shall be the third priority of the GHG Reduction Plan, including but not limited to:</p> <p>w. Implement California generated offsets compliant with a protocol approved by the California Air Resources Board (CARB).</p> <p>Offsite measures within North America shall be the fourth priority of the GHG Reduction Plan, including but not limited to:</p> <p>x. Implement North American generated offsets compliant with a protocol approved by the California Air Resources Board (CARB).</p>					
<p>HAZ-1. Operation of the project shall not include diesel or other vehicle fuel dispensing or the painting of vehicles.</p>	<p>Ongoing</p>	<p>CDD</p>	<p>X</p>	<p>Shown on building plans.</p>	<p>Before building permit issuance.</p>
<p>HAZ-2. The project shall acquire and maintain all required permits and approvals from the SLO County Department of Environmental Health for the handling and storage of hazardous materials.</p>	<p>Ongoing</p>	<p>SLO County Environmental Health Department</p>	<p>X</p>	<p>Required before building permit issuance</p>	<p>Before final building inspection.</p>
<p>N-1. On-site truck circulation, service department operations, and outdoor CNG vehicle maintenance area</p>	<p>Ongoing</p>	<p>CDD</p>			<p>Ongoing enforcement.</p>

Exhibit A

Mitigation Measure PD22-02 / CUP22-16 / RZN22-03 / P22-0017 and CUP23-03 / P23-0019 (Peterbilt and Outfront Media)	Type	Monitoring Department or Agency	Shown on Plans	Verified Implementation	Timing/Remarks
activities shall be limited to daytime hours only (7am – 7pm).					
N-2. South and west service bay doors shall be in the closed position at all times while air hammer equipment is in use.	Ongoing	CDD			Ongoing enforcement.
N-3. No air hammers or hydraulic lifts shall be used or installed outside the indoor service area including the outdoor CNG vehicle maintenance area.	Ongoing	CDD		Shown on building plans.	Before building permit issuance and ongoing enforcement.
N-4. Any amplified public address system shall be designed to not exceed 65dB L _{max} at the nearest residential property line.	Project / Ongoing	CDD		Results of noise analysis and testing of system submitted to City.	Before building permit issuance.

(add additional measures as necessary)

Explanation of Headings:

Type: Project, ongoing, cumulative

Monitoring Department or Agency: Department or Agency responsible for monitoring a particular mitigation measure

Shown on Plans: When a mitigation measure is shown on the plans, this column will be initialed and dated.

Verified Implementation: When a mitigation measure has been implemented, this column will be initialed and dated.

Remarks: Area for describing status of ongoing mitigation measure, or for other information.